

GAPS

Technical Description

Abbreviations and Acronyms

APRS	Acoustic Positioning Reference Sensor
AUV	Autonomous Unmanned Vehicle
CBIT	Continuous Built-In Test
DP	Dynamic Positioning
FOG	Fiber Optical Gyroscope
FPSO	Floating Production Storage and Offloading
GAPS	Global Acoustic Positioning System
GPS	Global Positioning System
ICD	Interface Control Document
IMU	Inertial Measurement Unit
INS	Inertial Navigation System
ITS	iXblue Telegram Service
MMI	Man Machine Interface
MRU	Motion Reference Unit
NIS	Noise Isotropic Spectrum
NMEA	National Marine Electronics Association
OBC	Ocean Bottom Cable
ROV	Remotely Operated Vehicle
RTK	Real-Time Kinematics
SNR	Signal to Noise Ratio
USBL	Ultra Short Base Line

Table of Contents

1	IXBLUE CORPORATE DESCRIPTION	4
1.1	THE COMPANY	4
1.2	WORLDWIDE PRESENCE	5
1.3	ACOUSTIC PRODUCTS DIVISION	7
2	GAPS DESCRIPTION	8
2.1	PRODUCT DESCRIPTION	8
2.2	BASIC PRINCIPLE	9
2.3	COMPONENTS	10
2.4	GAPS ADVANTAGES	10
2.5	PACKING AND SHIPPING	12
2.6	GAPS IV, THE LATEST PRODUCT’S GENERATION	12
3	GAPS APPLICATIONS	13
4	GAPS DIAGRAM ASSEMBLY	14
5	GAPS FUNCTIONALITIES	15
5.1	SUBSEA POSITIONING	15
5.2	ITS – IXBLUE TELEGRAM SERVICE	15
5.3	SURFACE NAVIGATION AND ATTITUDE COMPENSATION	16
5.4	L/USBL/INS FOR DYNAMIC POSITIONING	17
5.5	SOUND VELOCITY PROFILE AND RAY BENDING COMPENSATION	18
5.6	NOISE SPECTRUM DISPLAY	18
5.7	TELECOMMAND	19
5.8	PING STACKING	19
5.9	INPUT/OUTPUT	20
5.10	GAPS WEB MMI	21
5.11	DELPH ROADMAP	22
5.12	INTERFACING TO NAVIGATION SOFTWARE	25
6	GAPS + INS NAVIGATION	26
7	COMPATIBLE TRANSPONDERS	28
8	GAPS DEPLOYMENT METHODS	30
8.1	POLE MOUNT (DRAWING PROVIDED ON REQUEST)	30
8.2	MOON POOL	31
8.3	IXBLUE HOISITING SYSTEM	31
8.4	EXISTING HOISITING SYSTEM	32
8.5	REMOTE TOWED PLATFORM	32
8.6	SURFACE BUOY	33
8.7	SURFACE DRONE (USV)	33
9	INTERFACING	34
10	GAPS REPEATER BOX	35
11	GAPS SPECIFICATION	36

11.1	SYSTEM (GAPS + CABLE + BOX)	36
11.2	GAPS HEAD	38
11.3	GAPS BOX	39
11.4	MAIN CABLE	40
12	GAPS PERFORMANCES	41
12.1	MAXIMUM RANGE	41
12.2	BEARING ACCURACY	42
12.3	POSITIONING ACCURACY	42
12.4	MAXIMUM RANGE DEPENDING ON BEACONS	43
12.5	POSITIONING ACCURACY DEPENDING ON BEACONS	44
12.6	POSITIONING ACCURACY DEPENDING ON ELEVATION	45
12.7	PERFORMANCES FOR DYNAMIC POSITIONING	46
12.8	OBTAINED PERFORMANCES IN SHALLOW WATER (VERTICAL CONDITIONS)	47
12.9	OBTAINED PERFORMANCES IN SHALLOW WATER (HORIZONTAL TRACKING)	49
13	LIFE CYCLE	50
13.1	PACKAGING, HANDLING, STORAGE, TRANSPORTATION REQUIREMENTS	50
13.2	CALIBRATION	50
13.3	BUILT-IN TEST	50
13.4	RELIABILITY & MAINTAINABILITY	50
13.5	HYDROPHONE/LEG REPLACEMENT	51
14	REFERENCES	52
15	DRAWINGS	54

1 iXblue corporate description

1.1 The company

iXblue is an independent group and a leading global manufacturer of products, integrated solutions and systems for navigation, mapping, control and measurement technologies. iXblue incorporates a wide range of capabilities to deliver world leading solutions to the offshore, land, air, space, defense, industry and photonics market. For the past number of years iXblue has been implementing a sustained policy of growth and has expanded its core competencies and its capacity to offer system solutions for these markets.



Pioneers of cutting edge technology solutions, iXblue invents and offers solutions that are cost effective, time efficient, reliable and straightforward to use. iXblue offers a broad and unique range of complementary products built on the following key technologies:

- FOGs (Fibre Optic Gyroscopes) and INS (Inertial Navigation Systems)
- Underwater acoustic (USBL positioning, transducers and remote control)
- Imagery and seafloor mapping (sonar, seismic, magnetic and data acquisition systems)

iXblue comprises today six business units: navigation systems, photonics solutions, sea operations, acoustic systems, marine works and motion systems.

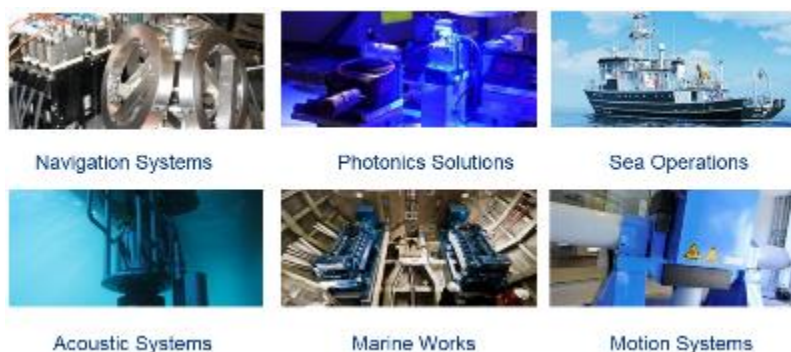

The name iXblue is synonymous with brand quality, its mastery of the inertial and sensor market, continuous innovation and best customer service. For each technology, iXblue is one of the rare highly skilled companies in its field. It benefits from important technological advantages in its research and development and from a policy of open communication and feedback from clients. These cutting edge products are very competitively priced, as iXblue does not have to pass on intermediary sensor purchase costs.

iXblue do also provide complete solutions to its customers, defining with them the solution that best fits their needs. The designed system can incorporate iXblue and/or third party equipment, hardware and software, fully integrated. The turnkey solution includes all the necessary services: engineering, installation and test, training, premium customer support and maintenance.

iXblue has been engaged for several years in a quality process to maximize the satisfaction of its customers. iXblue is certified ISO9001-2008.



1.2 Worldwide presence

Functional With a sustained growth, a staff of over 600 and a total of three quarters of turnover accounting for exports, iXblue has a true worldwide market presence.



A dedicated customer support department for helpline and on-field support is available worldwide 24 hours a day, all year round by telephone or email.



NORTH AMERICA / NORAM
+1 508 975 4640 ext 1

EUROPE MIDDLE-EAST AFRICA LATIN-AMERICA / EMEA-LATAM
+33 1 30 08 98 98

ASIA PACIFIC / APAC
+65 6747 7027

1.3 Acoustic Products Division

The Acoustic Products Division is based in Brest (France) and designs and manufactures top-of-the-art and turnkey solutions for subsea positioning.



GAPS
Fully integrated and pre-calibrated USBL system

Benefit & Applications
High performance in all environments and tracking conditions.
AUV, ROV, towed vehicle, divers..

POSIDONIA II
Ultra long range USBL system

Benefit & Applications
Proven USBL tracking solution for extreme ranges up to 10,000 m

RAMSES
Acoustic Synthetic BaseLine System (ASBL)

Benefit & Applications
The perfect companion for use with iXblue INS. Sparse-Array positioning, SIAM, IBI modes



OCEANO range
Range of low or medium frequency transponders & releasers

Benefit & Applications
Reliability, low power consumption, wide range of transponders and releasers

Heavy Duty AR's
Heavy Duty acoustic releases for marine construction

Benefit & Applications
A unique solution for heavy load handling and marine construction

ComMet (system)
Combined acoustic-inertial subsea metrology system

Benefit & Applications
Ultimate performance and reduced operation time with INS and acoustics combination

2 Gaps description

2.1 Product description

Gaps is a high performance integrated underwater positioning solution which makes USBL (Ultra Short Base Line) underwater positioning extremely simple to operate from any vessel, using a portable and truly pre-calibrated USBL head coupled with internal INS (Inertial Navigation System) and GNSS. The Gaps also enables exchange data between the Gaps transceiver and the beacon using acoustic communication.

Gaps measures the absolute position of one or more subsea objects or vehicles which can navigate at depths up to 4,000 meters, with 200 deg hemispherical coverage below the antenna. Depending on environmental conditions, the positioning accuracy is up to 0.06% of the slant range and the data rate is 500 bits/second for the acoustic communication. These objects or vehicles are located using acoustic transponders or beacons and a subsurface acoustic array (Gaps head) typically deployed under water below the ship hull or from any surface platform.

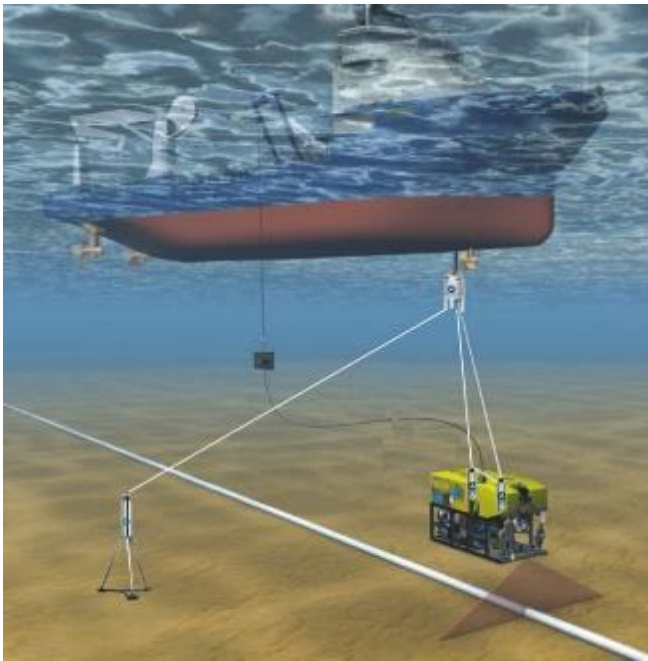

USBL systems

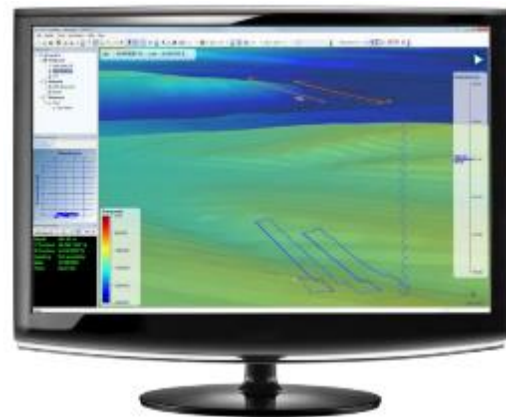

Visualization software

Gaps is used for tracking and communicating with subsea devices (ROVs, AUVs, structures, towfish, divers...) and for dynamic positioning applications when transponders are fixed on the seabed.

The Gaps meets the needs of oil & gas, defense, marine construction, survey and scientific applications.

2.2 Basic principle

USBL principle is based a two-ways acoustic communication between the USBL transducer - on surface - and the transponder - on the object to track. The transducer transmits an interrogation signal that reaches the beacon. The beacon detects this interrogation signal and replies another signal.

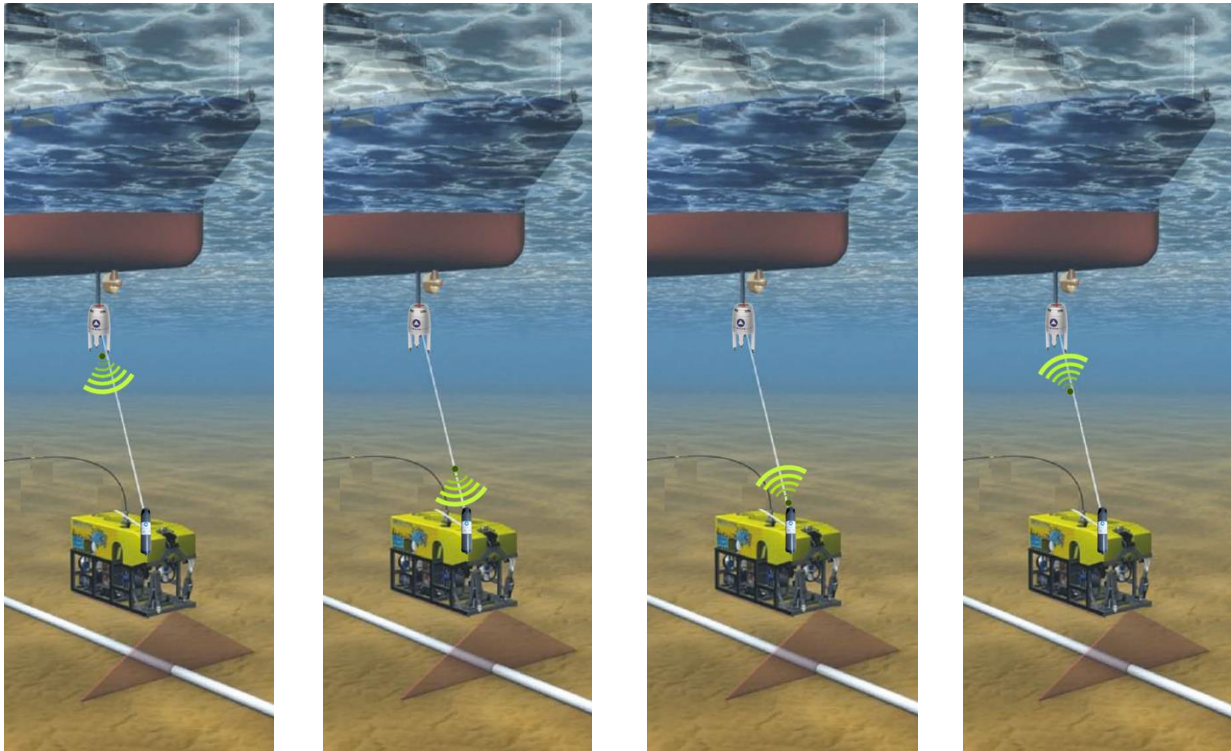

Acoustic transmission sequence between Gaps antenna and the beacon

The beacon reply is detected by the surface antenna and is processed to determine the phase difference between hydrophones and then, the exact direction of the beacon. Slant range is measured knowing the speed of sound and the time elapsed between the interrogation and the reply. Since the acoustic array is installed on a moving platform (surface ship), its absolute motion is known thank to its internal INS that provide geographic true heading and roll/pitch with high accuracy.

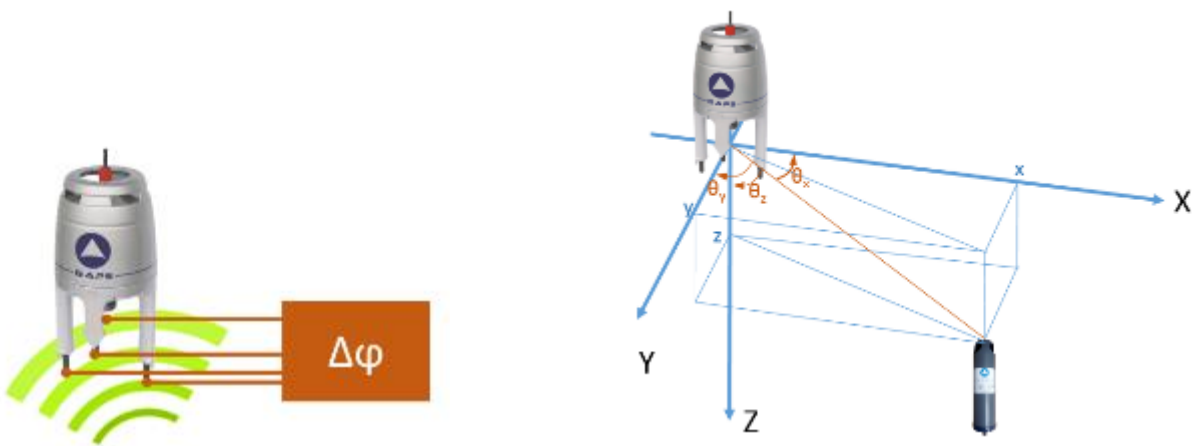

Phase difference between hydrophones and position measurement

2.3 Components

Gaps comprises, in a single lightweight housing (carbon fiber made), all required components to achieve USBL positioning including the INS. The system is plug and play, deployable in an instant, and can be operated immediately thanks to its pre-calibrated concept.

The **INS** is the inertial navigation system composed of three Fiber Optic Gyroscopes (FOG) and three accelerometers mounted on orthogonal axis. The INS provides the exact position and attitude with very high level of accuracy and high update rates. Heading is provided with an accuracy of 0.01° seclat making it one of the best performing INS.

The acoustic array is composed of one (1) transmission **transducer** and four (4) reception **hydrophones**. It ensures the sending of the acoustic triggering signal to the transponders and the receiving of their replies. The acoustic array of the Gaps is 3D: it has four receiving hydrophones on the vertices of a tetrahedron (four is the minimum number of hydrophone for unambiguous positioning in 3-D space). This design implies very good angular coverage (>200 degrees aperture below the acoustic antenna).

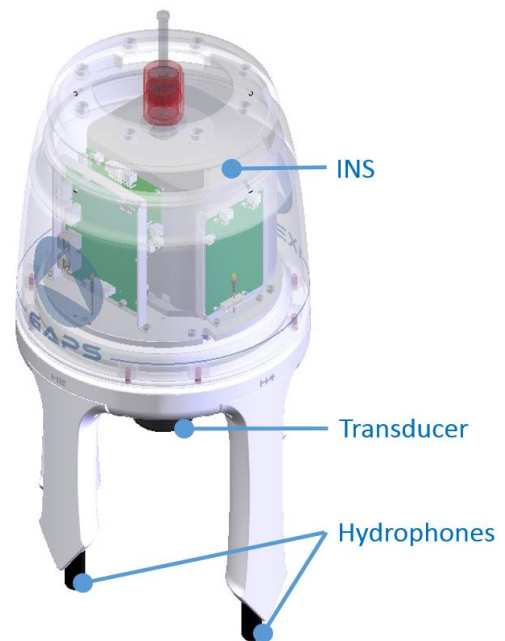

2.4 Gaps advantages

Taking advantage of its unique expertise in acoustic positioning and inertial sensors, iXblue introduces Gaps, the first acoustic + inertial integrated positioning system for marine and subsea applications.

It is an all-in-one system which can provide at the same time the position of a surface vessel and of several subsea vehicles or divers. It also provides a very accurate heading and attitude for the surface vessel with the highest accuracy and unrivalled performances in shallow or extreme shallow water depth thanks to unique receiving antenna design and enhanced digital signal processing techniques.

Gaps is a portable system (light weight and reduced size), does not require any complicated and time consuming installation (all-in-one pre-calibrated system), features very high performance thanks to data fusion of Acoustic, inertial and GNSS technologies and finally has no limit in terms of operation area (shallow and deep water, horizontal and vertical channel, short or long range).

Features

- Compact, all-in-one USBL solution
- High grade INS for ultimate performance
- 3D acoustic array geometry
- Wideband modulation
- Provide absolute georeferenced position for the beacon
- Compatible with all major navigation suites
- Easy to interface with subsea INS
- DP mode: L/USBL/INS (PRS, MRU & Gyro all in one)
- More than 500 available acoustic channels
- Unified iXblue web interface
- 3D display software included (DELPH RoadMap)
- Acoustic communication (ITS)

Benefits

- Rapid deployment
- Operational cost savings
- Pre-calibrated
- Easy to install
- Easy to operate
- Accurate positioning
- Robust performance
- Flexible deployment operations
- Horizontal tracking
- Wireless subsea communication



3D view of vessel trajectory (black) and ROV positions (blue)

2.5 Packing and shipping

Gaps system is delivered in 2 flight cases.

FLIGHT CASES	Dimensions (m)	Weight (kg)	Box
Gaps head	80 x 60 x 50	38	Pellicase
Gaps accessories (50m)	63 x 50 x 36	31	Pellicase
MT912S-R	73 x 24 x 18	13	Wooden box



Main box containing Gaps transducer



Accessories box containing the cable and the Gaps BOX



Box for the transponder

2.6 Gaps IV, the latest product's generation

Since its first introduction on the market back in 2005 Gaps iXblue R&D engineers have been continuously working to improve the system performance and provide an even better service.

Gaps-IV is the latest and only version now available, which among other things is providing:

- Bidirectional acoustic data link between Gaps head and beacon (acoustic communication)
- Full Ethernet compatibility and enhanced connectivity (4 Ethernet + 4 serial I/O's)
- The standard iXblue WEB based user interface (MMI) with common look and feel across the whole iXblue range of product
- More simultaneous tracked transponders
- And many more attractive features and characteristics to come with this new and open electronic and software platform.

3 Gaps applications

- **Oil & Gas**
Structure placement, ROV navigation, AUV & glider operations, towfish tracking, cable/pipe laying, diver tracking, exploration, drilling, DP, touch down positioning, mattress lay, plough/trench positioning, Out Of Straightness, BSR positioning, seismic (streamer, nodes, OBC), rig move, anchor positioning, riser positioning
- **Defense**
Diver tracking, AUV tracking, under hull inspection, imagery, mine counter measure
- **Scientific**
ROV, AUV, gliders and towfish tracking
- **Other**
Marine construction, cable laying, mining, seabed crawler positioning, touch down monitoring



Trenching

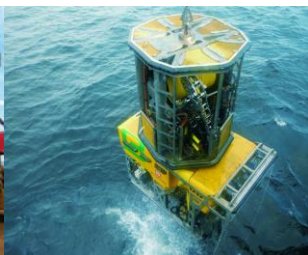

ROV tracking

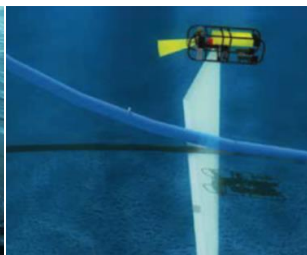

Touch Down Monitoring



Structure placement



Cut to length

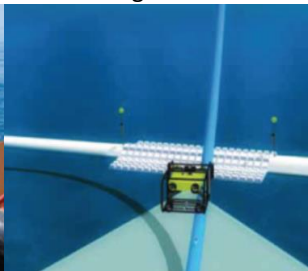

Pipeline crossing

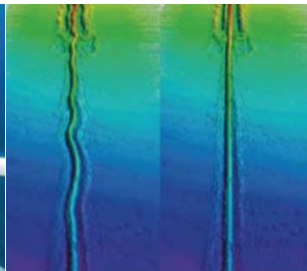

Pipeline survey



Ocean Bottom Cable



AUV



Diver tracking



Glider



DP



Towed sonar



Drilling



FPSO, Buoy Supported Riser Survey



4 Gaps diagram assembly

Gaps is a fully integrated system which does not require any further third party equipment to be operated. A comprehensive but reduced list of equipment is provided with the system. Its compact size, light weight, operating versatility and pre-calibrated characteristics make it usable in almost any kind of tracking operation with very quick and easy deployment. A standard Gaps system requires the following components for a ready to use configuration:

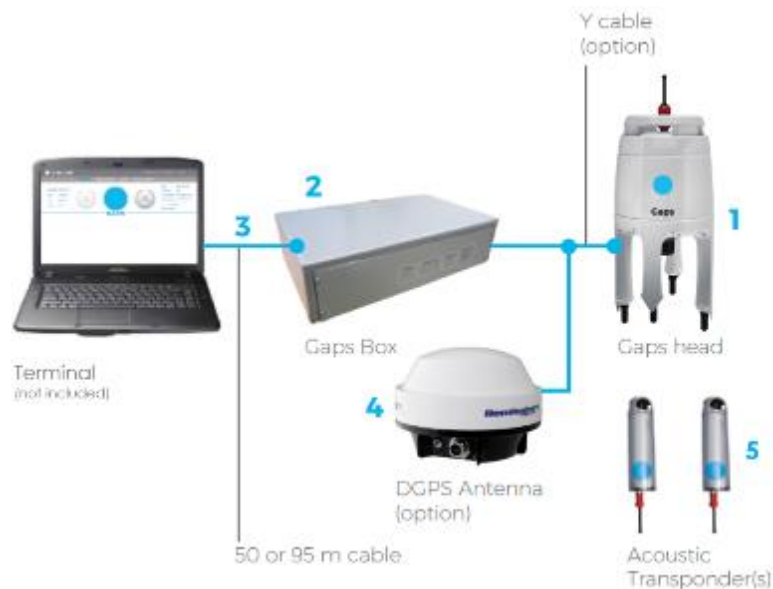

System diagram



This is the main part of the Gaps system, which comprises the acoustic array to communicate with the transponder(s) installed on the target(s), the INS for motion compensation and absolute georeferencing, and all electronics and signal processing.



Gaps Box designed to interface between the Gaps head and external peripherals. It includes power supply from mains & 28 Vdc, Ethernet connector, RS422 / 232 input/output and synchro in/out on BNC.



50 or 95 m long cable used to communicate with Gaps head. Possible options: ATEX, 95m and greater length using repeater Box.



A complete turnkey solution is available on option, including a GPS receiver, a 'Y' cable and a 15 m GPS cable.



Transponders are deployed on the vehicle or the object to track. Several models are available depending on the autonomy, the type of batteries and if an acoustic release is required.

5 Gaps functionalities

5.1 Subsea positioning

The Gaps can simultaneously track several fixed or mobile transponders. Every model of transponder has different interrogation and reply codes. The combination of interrogation and reply code makes a unique address for one transponder.

The maximum Gaps capacity:

- 40 beacons can be positioned simultaneously
- 500 beacons can be declared in the system (only 40 simultaneously “in use”)

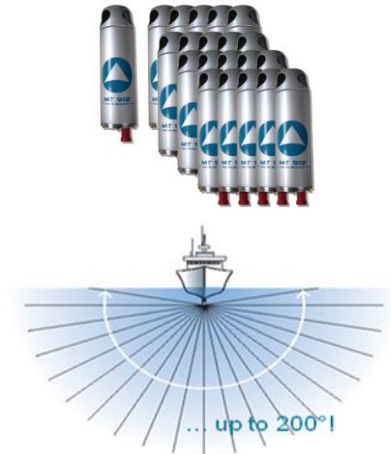

5.2 ITS – iXblue Telegram Service

The Gaps offers the iXblue Telegram Service and the full benefit of underwater wireless communication technology between the Gaps transducer and the beacon in half-duplex mode (Gaps to beacon and beacon to Gaps).

Tracking and communication are achieved simultaneously, using iXblue wideband telemetry modulation.

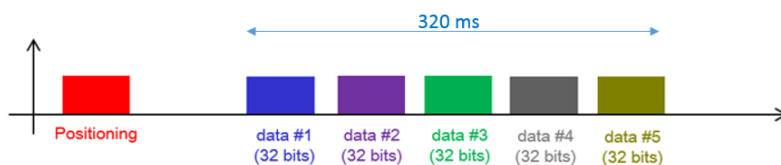

This can achieve a variety of communication tasks thanks to the user defined protocol:

- Broadcast information from a sensor to the surface
- Change the configuration of the beacon
- Get beacon status and internal sensor measurement (battery voltage, pressure sensor...)
- Send/get data to/from host
- Send position to a subsea INS

The data rate is 500 bps and it includes a robust error detection and correction method. This enable to send or receives 160 bits per recurrence. The Doppler is +/- 6 knots.

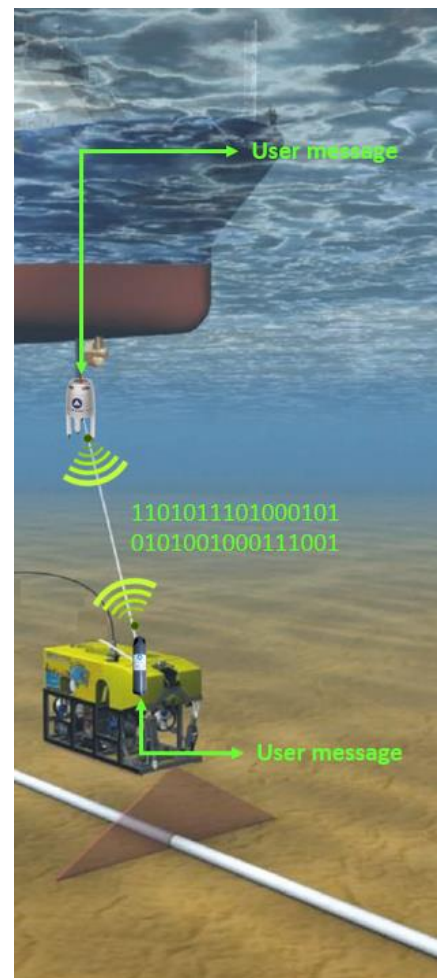

Control/command AUVs



Gaps enables simultaneous tracking and acoustic coms without the need to install dedicated modem transducer on the AUV or on the surface vessel. Gaps tracks, sends commands and receives AUV status, all with the same equipment.

Wirelessly send a position to a subsea INS



For AUV and ROV applications, Gaps enables to wirelessly send a position to a subsea INS:

- Gaps estimates the position of the beacon (USBL)
- Gaps sends to the beacon its position
- The beacon broadcasts to the subsea INS the position

Collect data from any subsea sensor

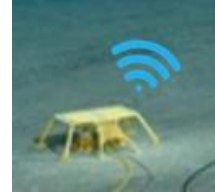

Any sensor can be interfaced to a subsea beacon. The beacon broadcasts through acoustic channel the measurements to the Gaps. It outputs the information on serial or Ethernet communication port.

Any Gaps IV can be updated to benefit from this new feature. Contact iXblue to know which models of beacons are compatible with this iXblue Telegram Service.

5.3 Surface navigation and attitude compensation



The Gaps is also an INS and can be used as such. If any sensor on the same mechanical structure than the Gaps requires to be compensated in heading, roll, pitch or position, one of the eight output of the system can be used to achieve this task.

As an example, a multibeam that would be deployed on the same side pole than the Gaps could be interfaced to the INS of the Gaps and compensated in heading/roll/pitch/heave and position.



5.4 L/USBL/INS for Dynamic Positioning

Gaps is ready to be interfaced to any Dynamic Positioning system in order to ensure follow target mode (when transponder is on a subsea vehicle) or auto position mode (when transponders are deployed on the seabed).

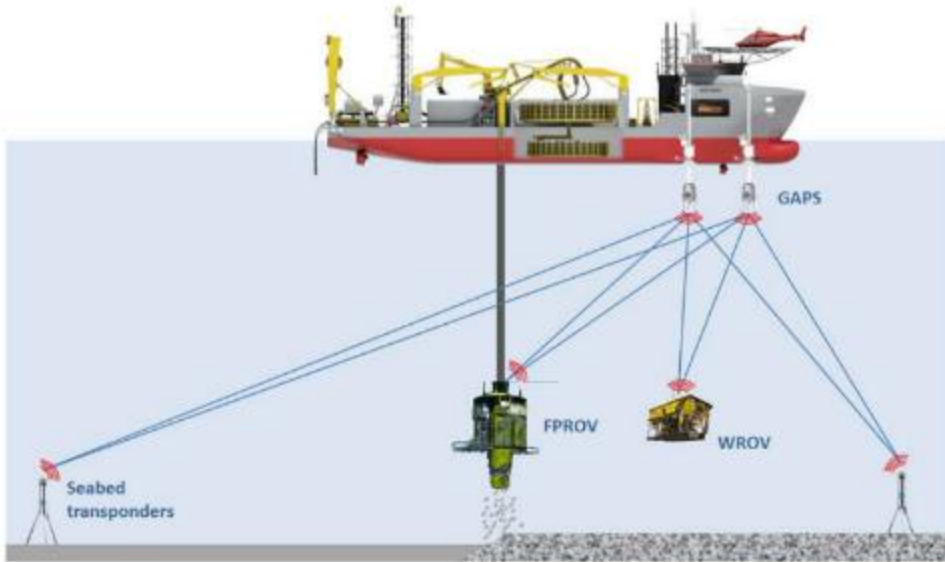

Gaps used for DP and ROVs tracking

Gaps becomes an Acoustic Positioning Reference Sensor (APRS) for the DP as well as a Motion Reference Unit (MRU) and a gyrocompass, all these functions being in the same equipment. Critical points are the positioning precision, the robustness to noise and information redundancy.

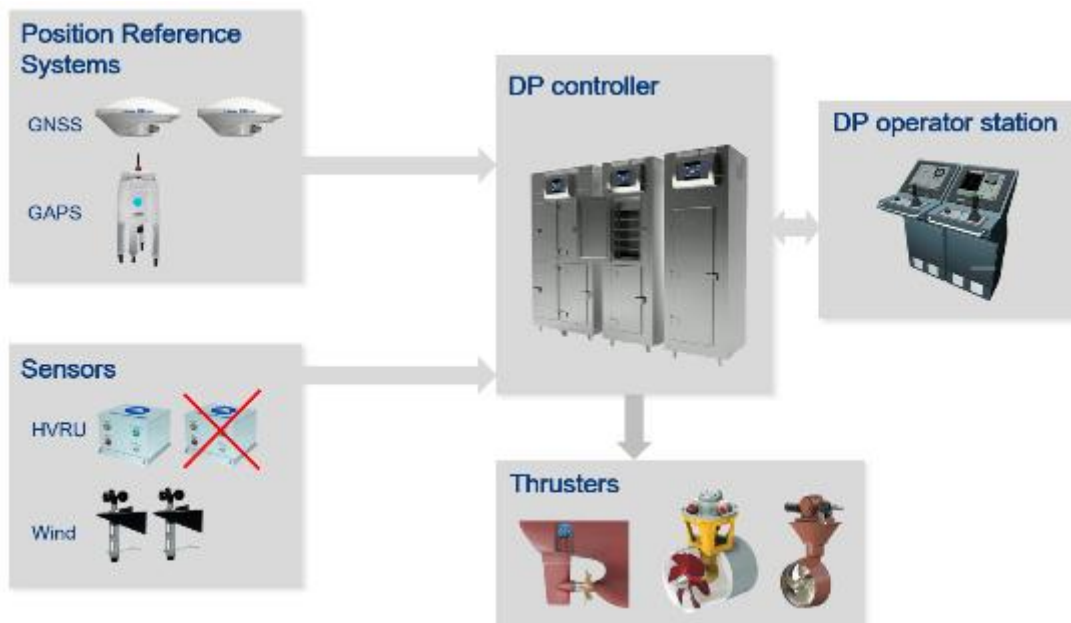

Gaps in a DP system

5.5 Sound velocity profile and ray bending compensation

Ray bending compensation is essential to provide accurate positioning. The sound velocity can be easily uploaded into the Gaps system through the Web-based control/command interface. A large number of file format are recognized.

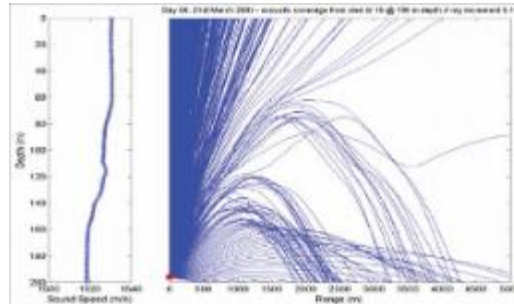

Sound velocity profile and ray bending compensation

5.6 Noise spectrum display

The Gaps enables to monitor the noise level. The estimated noise level is displayed into the web MMI through a spectrum graphic.

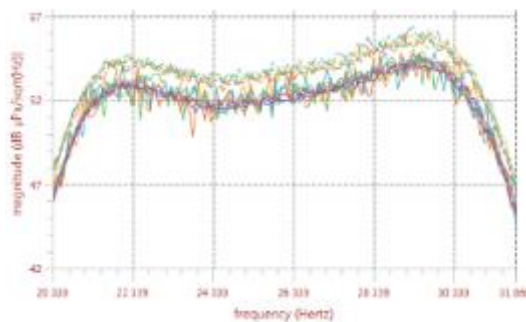

Noise spectrum display in Gaps web MMI

5.7 Telecommand

When used with RTA series, the Gaps is used to send release telecommands.



TELECOMMAND	
T Frequencies	
DBS	TCNAL 20.5kHz
DB1	TCNAL 22.5kHz
CAF	TCNAL 20kHz
T Codes	
ARN	DC
CMD	55: Release
T Acknowledge Timeout	
Timeout	10 s
<input type="button" value="Go back"/> <input type="button" value="Next"/>	

Telecommand settings in Gaps web MMI

5.8 Ping stacking

When operating Gaps with long slant ranges, the ping stacking enables to increase acoustic update rates whatever the water depth and the time required by the acoustic wave to propagate from the beacon to the Gaps transducer. Activating the ping stacking function enables to encapsulate several acoustic recurrences and have acoustic updates rates of 1 sec, whatever the water depth.

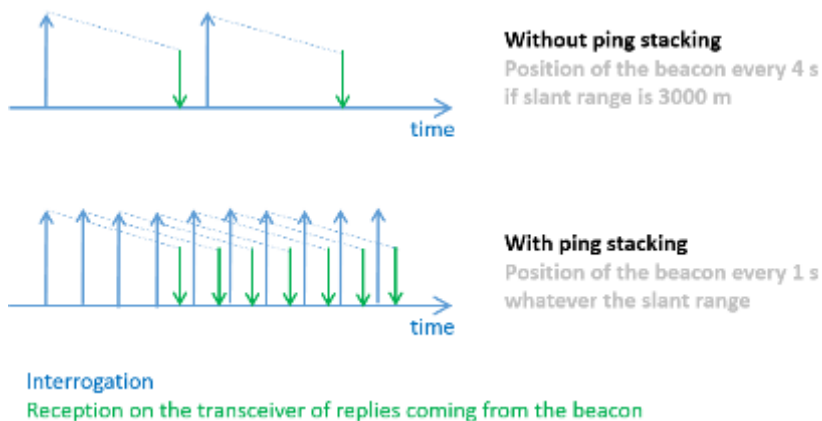

Ping stacking principle

5.9 Input/Output

All communication to and from Gaps are achieved using industry standard NMEA0183 data telegram through the serial input/output ports, messages content is fully described in the user manual provided with the equipment.

In addition to its standard proprietary communication protocol (“Gaps standard”) Gaps is featuring native compatibility with other iXblue sensors and subsystems (PHINS, RAMSES, etc..) and can emulate other industry standard protocols.

This allows Gaps to smoothly interface to iXblue or already existing third party hardware / software, or easily interface to peripherals or main system such as DP engines.

Examples of protocols for USBL positions:

- Gaps Standard
- HIPAP HPR 400, HPR418, HPRBCD
- NAUTRONIX
- iXblue USBL INS
- POSIDONIA 6000
- GPGGA

Examples of protocols for INS positions and attitudes (inside the Gaps antenna):

- HEHDT
- GNSS like
- GYROCOMPASS
- NAVIGATION
- OCTANS STANDARD
- PHINS STANDARD

5.10 Gaps web MMI

Gaps can be connected to a PC for configuration, installation and display purposes through a Web-based User Interface software. The Gaps web interface Gaps is used to:

- Configure Gaps (input/output configuration, sound velocity profile, etc).
- Control the position(s) of the transponder(s) and the status related to the quality of the positioning.

User-friendly menu screens allow the operator to define Gaps setting before deployment in an instant. The use of the control system is not mandatory once Gaps is configured. Gaps keeps all its settings when powered off and resume its last behaviour when started up.

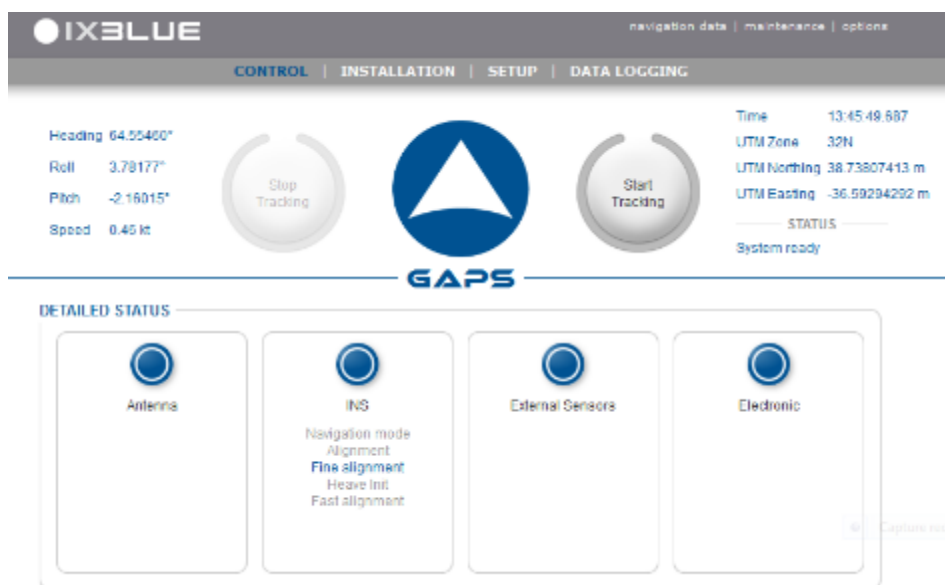

Example of a page of Gaps web interface

This Web-based control/command software is also used for maintenance purposes. All the firmware can be downloaded into the Gaps and does not require to open the Gaps housing.

Alternatively and when Gaps is part of a system, it can be controlled/commanded using URL commands coming from a supervision software. The ICD (Interface Control Document) can be provided on request for the description of the commands.

5.11 DELPH RoadMap

DELPH RoadMap is the common 3D cartographic module of DELPH software product line. Originally used for geophysical data processing and visualization, its range of application has been extended to 3D trajectory monitoring. DelphRoadMap software is provided with the Gaps system.

DELPH RoadMap uses a standard Microsoft Windows user interface and is a cartographic display that aggregates geo-referenced data in a single 3D view. All input layers (vectors, rasters) display in a map that uses a user-configured geodetic system. DELPH offers a large library of geographic (GCS) and projected (PCS) cartographic systems, with the advanced capabilities of extending this library with user-configurable geodetic systems and reprojecting information layers on the fly.

DELPH RoadMap can display live and offline data coming from positioning devices such as iXblue USBL products which are Gaps and POSIDONIA. With a very simple connection, live acoustic positioning data will display in DELPH RoadMap 3D map including USBL sensor location and acoustic beacons positions and trajectories.

Real-time data input

DELPH RoadMap connects to positioning equipment using:

- Ethernet TCP/IP connection
- Ethernet UDP (broadcast) connection
- RS232 Serial port link

It has support for the main data protocols supplied by the equipment:

- iXblue USBL protocol \$PTSAG
- iXblue INS protocol PHINS-STANDARD
- NMEA protocol (GGA, GLL, RMC, HDT)

When data is received, mobiles automatically create in DELPH RoadMap. Their appearance can be customized using:

- Pre-defined 3D objects (sphere, cube, etc.)
- User-supplied 3D models (3DS format)
- Custom size
- Custom offsets (translate and rotation)



Offline data input

Previously recorded data can be opened in DELPH RoadMap by inserting data records from supported protocols into the project.

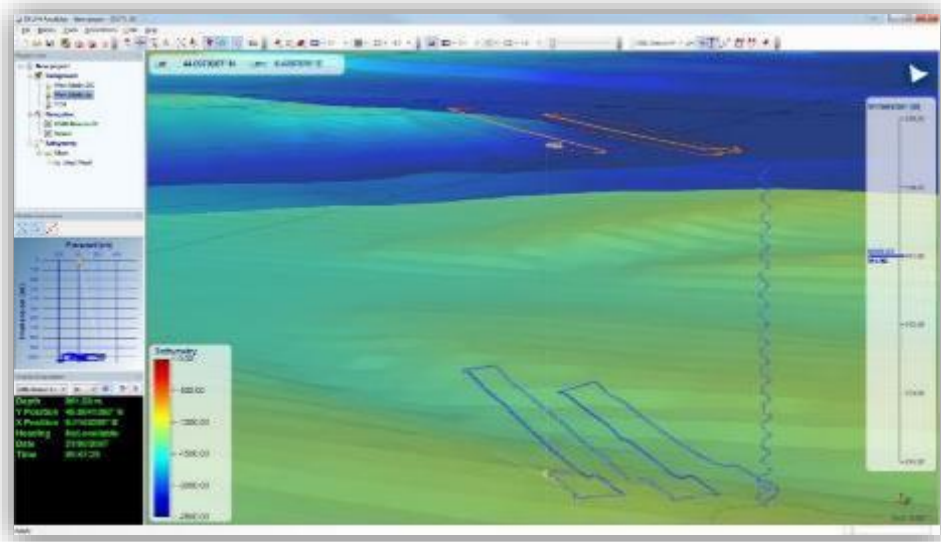

Replay data input

Previously recorded data can be opened in DELPH RoadMap by inserting data records from supported protocols into the project.



Display

DELPH RoadMap cartographic view may be using different camera modes:

- 3D visualization
- 2D visualization
- Relative positioning

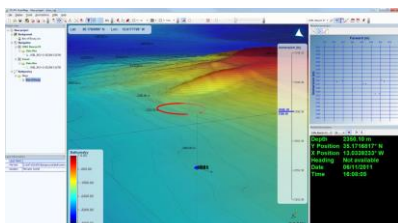

3D view

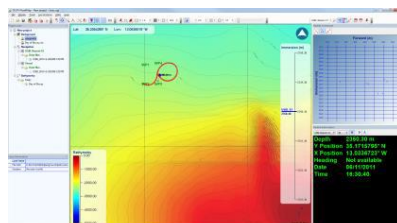

2D view North Up

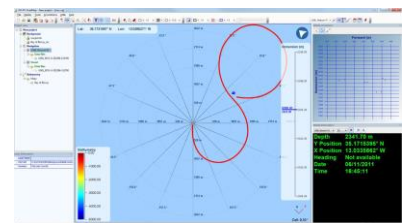

Relative view

Real-time measurement

Users can easily choose couple of items for which they want to display measurement information in side panel and / or in the 3D view:

- Horizontal Distance: On the map projection or ellipsoid
- Vertical Distance
- Slant Distance
- Horizontal Bearing: On the map projection or ellipsoid
- Vertical Angle

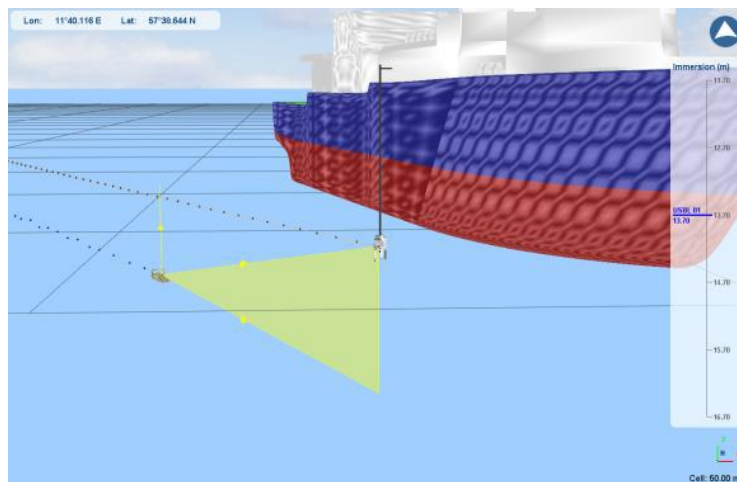

Slant range, horizontal and vertical distance measurement between Gaps head and ROV

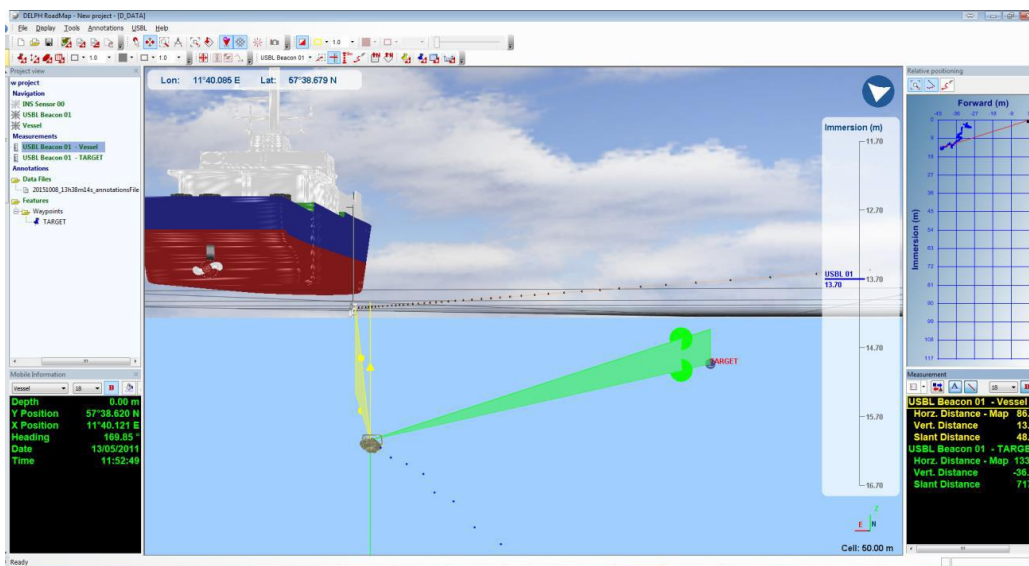

Slant range, horizontal and vertical distance measurement between ROV and a waypoint

5.12 Interfacing to navigation software

Gaps system provides data telegrams with each transponder’s position for use with any third party navigation package, with various communication protocols.

Up to 8 Serial or Ethernet output are available which allow data distribution to different peripherals.

Industry standard data telegrams are provided to easily interface each sensor to standard navigation packages from the market place such as Winfrog, Quinsy, etc.



GATOR



QINSY



NAVIPAC



HYDROPRO



HYPACK



STARFIX
WINFROG



DELPHROADMAP
GECDIS

6 Gaps + INS navigation

Gaps can be interfaced to a subsea INS. The subsea INS receives the USBL position of the beacon (through the umbilical or using acoustic communication) and the INS make the fusion of all available internal or external sensors (accelerometers, gyroscopes, pressure sensor, DVL, USBL) to deliver an optimized position of the ROV. This architecture brings the following advantages:

- Position of the ROV is updated every 10 ms (whatever the acoustic update rate)
- Position of the ROV is updated even when Gaps does not detect the beacon
- The subsea INS rejects the erroneous USBL positions
- The subsea INS filters/smooth the USBL positions

The INS improves by a factor higher than 3 the positioning accuracy of the USBL if used alone.

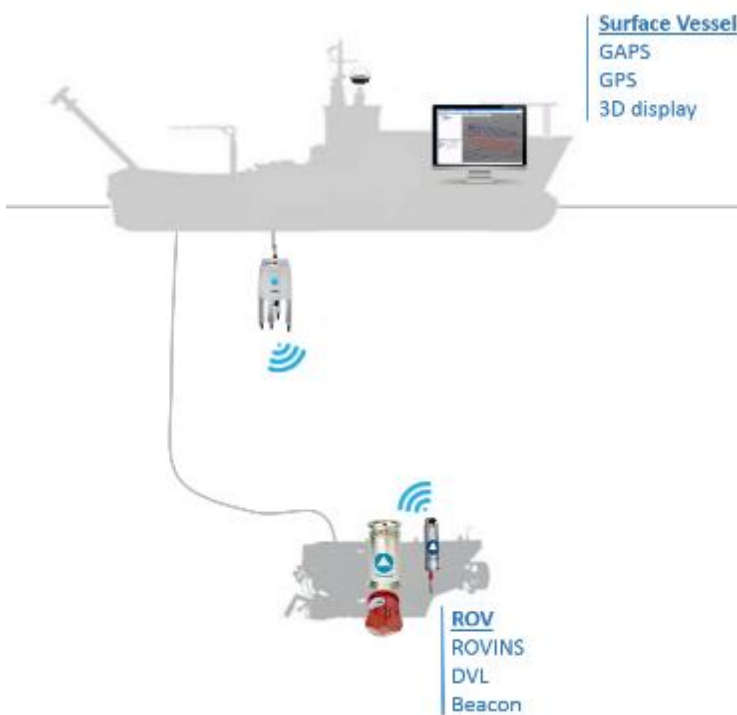

Gaps and INS system architecture

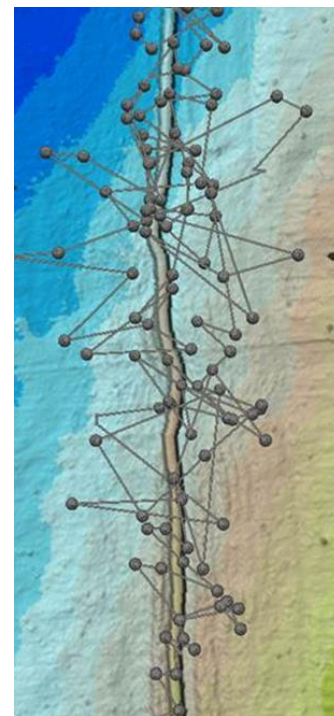

USBL positions (dots)

USBL + DVL + INS positions (line)

USBL	PHINS + DVL + USBL	Ratio
0.97 m (1 σ)	0.18 m (1 σ)	5.4
0.81 m (SEP)	0.15 m (SEP)	

Positioning accuracy comparison (with and without the INS)

The system integration requires different interfaces between surface and subsea equipment as shown on following diagram.

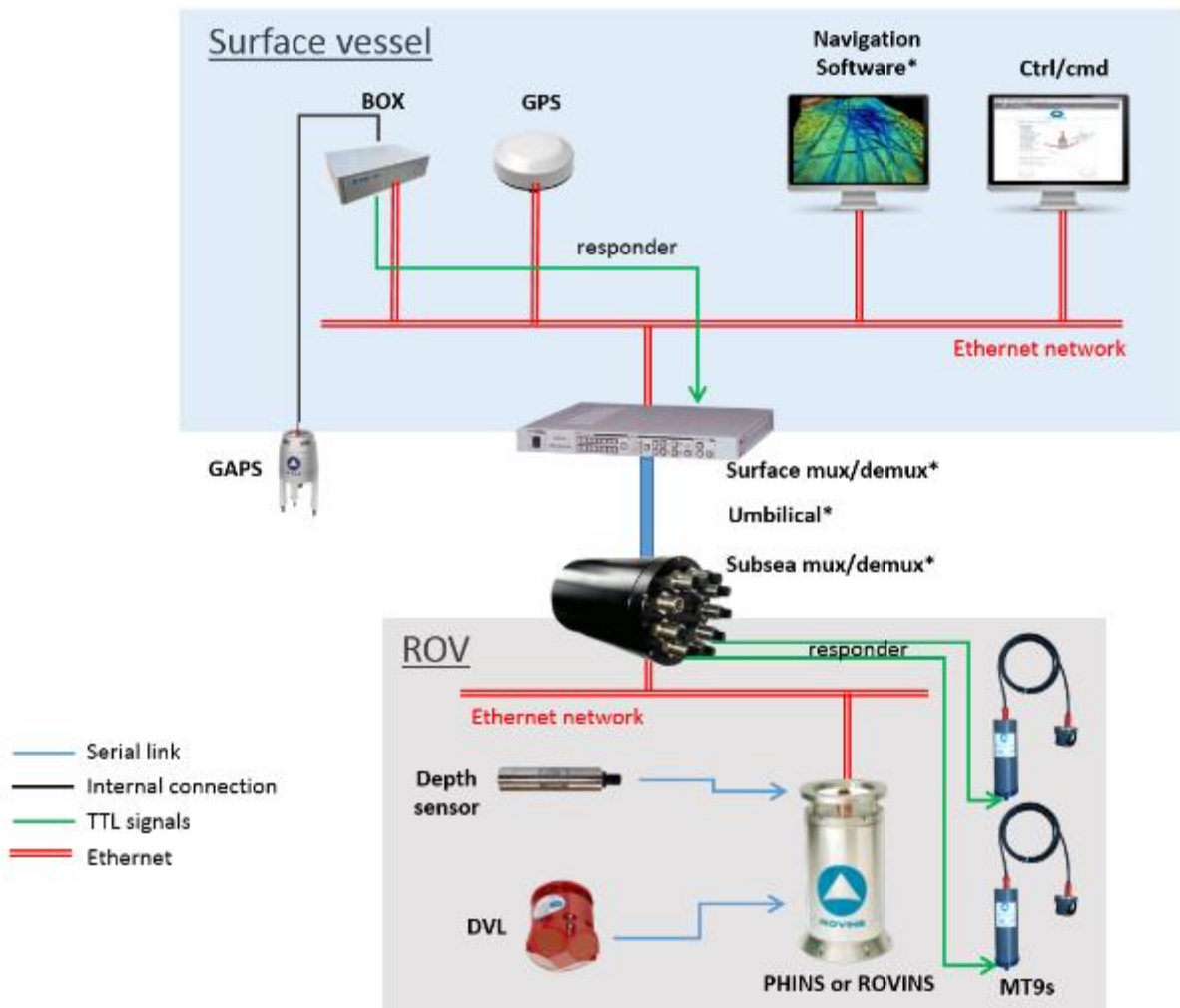









Gaps and INS system interfacing

7 Compatible transponders

Transponders/Responders are the remote part of the Gaps positioning solution. They are installed on the subsea vehicle or target to position.

Gaps is able to position iXblue and third party transponders. The list of compatible transponders is given below.

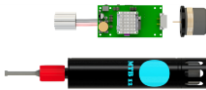
	<p>iXblue MT8x2 Mini beacon Lithium batteries</p>		<p>iXblue RTAx2 Releasable transponder</p>
	<p>iXblue MT9x2 Mini beacon Rechargeable battery</p>		<p>iXblue RAMSES Synthetic LBL positioning system</p>
	<p>iXblue ZTAx2C Beacon for seismic applications</p>		<p>Applied 1000 series (Micro, Mini, Midi, Fatboy, Seabed)</p>
	<p>iXblue ET862 Expandable transponder</p>		<p>Sonardyne Wideband™ 1 modulation</p>
	<p>iXblue MTB-OEM Beacon with telemetry for integration into AUVs</p>		

The positioning performance are not the same depending on the type of transponder. See dedicated paragraph.

Sub-family	Model	Depth (m)	Load Capacity in T (RL / SWL)	Housing	Size (L x OD in mm)	Weight in kg (air / water)	Stand by (month)	Nb of Gaps pings	Nb of addresses	Dual use	Configuration	Telemetry (ITS)	External power supply	Responder	Remote transducer	Lithium batteries	Pressure sensor	Acoustic release
Expendable	OCEANO ET862S	6 000	N/A	Super Duplex Stainless Steel	712 x 130	25.5 / 16	54	500 000	8	YES	Internal switch		<input type="radio"/>	<input type="radio"/>	<input type="radio"/>	<input type="radio"/>		
	OCEANO ETA62S	6 000	N/A	Super Duplex Stainless Steel	574 x 130	21 / 15	30	480 000	8	YES	Serial link Internal connector		<input type="radio"/>	<input type="radio"/>	<input type="radio"/>	<input type="radio"/>		
Releasable	OCEANO RTA62CS	6 000	0.5 / 2.5	Super Duplex Stainless Steel	625 x 126	24 / 17.5	30	480 000	8	YES	Serial link internal connector		<input type="radio"/>	<input type="radio"/>	<input type="radio"/>	<input type="radio"/>		<input checked="" type="radio"/>
	OCEANO RTA62B2S	6 000	2.5 / 2.5	Super Duplex Stainless Steel	725 x 126	27 / 20.7	30	480 000	8	YES	Serial link internal connector				<input type="radio"/>	<input type="radio"/>		<input checked="" type="radio"/>
Miniature	MT832E-R	3 000	N/A	Aluminium	500 x 70	2.8 / 1.2	4	50 000	8	YES	Internal switch		<input checked="" type="radio"/>	<input checked="" type="radio"/>	<input type="radio"/>	<input checked="" type="radio"/>	<input type="radio"/>	
	MT862S-R	6 000	N/A	Super Duplex Stainless Steel	490 x 70	5 / 3.5	4	50 000	8	YES	Internal switch		<input checked="" type="radio"/>	<input checked="" type="radio"/>	<input type="radio"/>	<input checked="" type="radio"/>	<input type="radio"/>	
	MT912S-R	1 000	N/A	316L Stainless Steel	377 x 91	4.4 / 2.3	5	100 000	40	NO	USB External connector		<input checked="" type="radio"/>	<input checked="" type="radio"/>	<input type="radio"/>	<input checked="" type="radio"/>		
	MT932S-R	3 000	N/A	316L Stainless Steel	368 x 91	5.7 / 3.8	5	100 000	40	YES	USB External connector		<input checked="" type="radio"/>	<input checked="" type="radio"/>	<input type="radio"/>	<input checked="" type="radio"/>		
	ZTA02C	500	N/A	Composite	396 x 98	3.9 / 1.4	16	500 000	506	NO	Wireless, Zigbee®							
	ZTA32C	3000	N/A	Composite	416 x 105	5.5 / 2.3	16	250 000	506	YES	Wireless, Zigbee®							
OEM	MTB series	OEM 1000 4000	N/A	TBD	TBD	TBD	TBD	TBD	506	YES (4000)	Wireless	<input checked="" type="radio"/>	<input checked="" type="radio"/>	<input checked="" type="radio"/>	<input checked="" type="radio"/>			

standard optional

8 Gaps deployment methods

Examples below demonstrate the extreme ease of operation of the system which does not require sophisticated mechanical pole or deployment machine to operate it.

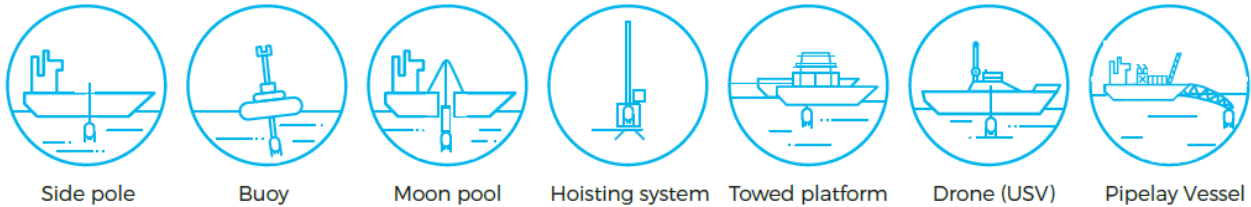

8.1 Pole mount (drawing provided on request)

This kind of installation is the most commonly used. A pole is installed on the side of the vessel and can be rotated in 2 positions: one position for the survey (side pole is vertical) and one position for the transit (side pole is horizontal).

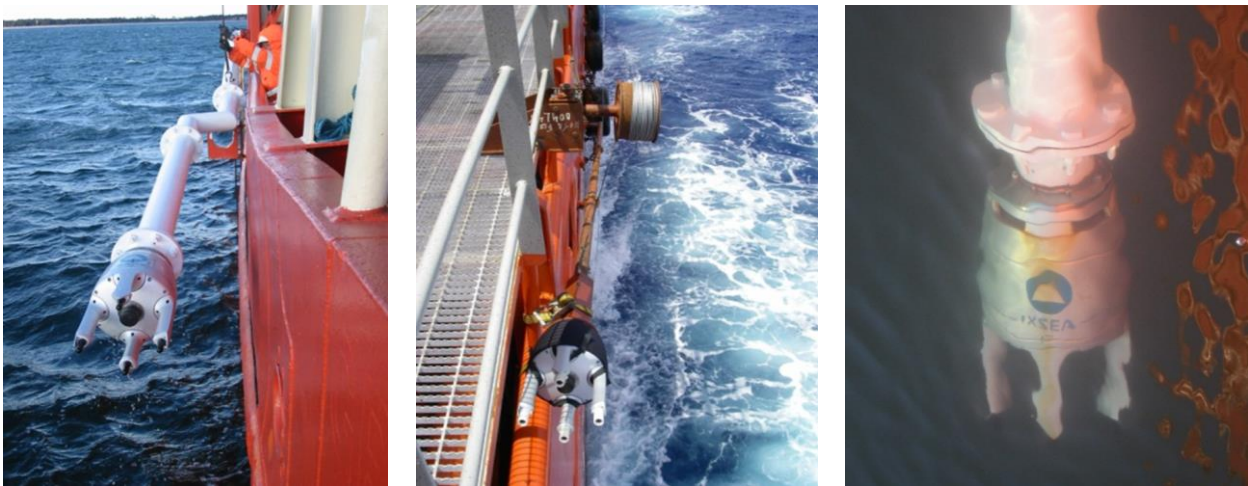

8.2 Moon pool

For vessels equipped with moon pools, Gaps can be very easily deployed with a pole and a lifting system to recover the equipment.



8.3 iXblue hoisting system



The iXblue hoisting system is a robust and reliable hydraulically operated pole which is designed for the deployment of iXBlue USBL head (Gaps and POSIDONIA) below the vessel hull for permanent installations.

The service chest with inspection door allows to access the equipment without dry-docking the vessel. The whole system is to be installed on the flange of a through hull penetration pipe.

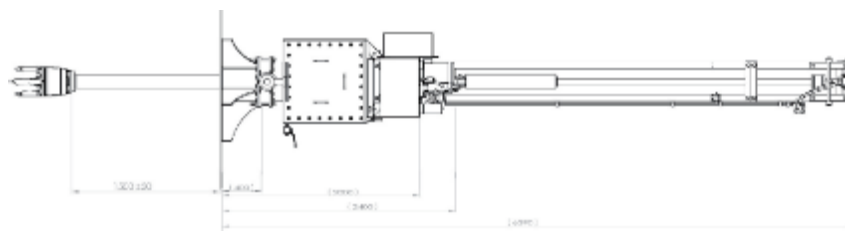

8.4 Existing hoisting system

Gaps can also be installed in existing hoisting system when gate valve is diameter is greater than 300 mm (external diameter is only 296 mm, i.e. 11.7 inch). Some examples below:



8.5 Remote towed platform

This deployment method is sometime used to drive away the Gaps head. This reduces the noise received by the USBL head and this improves the performances (maximum range and positioning accuracy).



iXblue design

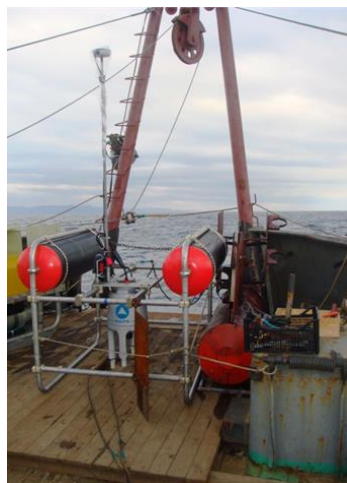

Yuzhmorgeologya (Russia)

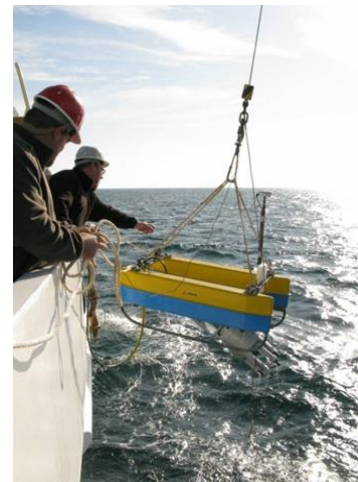

Instituto Hidrografico (Portugal)

8.6 Surface buoy

Thanks to the INS inside the USBL transceiver, very light platforms such as simple buoys + pole can be used for some applications.



8.7 Surface drone (USV)

Because of its dimensions and its weight, Gaps is easy to integrate onto Unmanned Surface Vessels. No surface electronic rack is required, all the processing is done into the transceiver. The INS can be used for the navigation of the drone.



9 Interfacing

Interfacing is done from the rear panel of the Gaps BOX:



INTERFACING	
Power supply / consumption	100 to 240 VAC - 50~60Hz or 24 to 36 VDC / 35 W (45 W peak)
Connector for VDC	SOURIAU 4-pins - UTO00104PH
Main connector to Gaps head	SOURIAU 23-pins - UT061823PH
Ethernet communication port	1 x RJ45 plug
Serial communication port	4 x DB9 connectors for RS232 or RS422/485 serial links
Synchronization IN & PPS	2 x BNC connectors (trigger and PPS)
Synchronization out	2 x BNC connectors (main and secondary)

10 Gaps repeater box

The Repeater Box is necessary when two main cables (95 + 95 m or 95 + 50 m) are used simultaneously between the Gaps BOX and the Gaps unit. The Repeater Box realizes the junction between the two cables. Standard main cables are used so the connectors on the Repeater Box are similar to connectors on the Gaps BOX and on the Gaps antenna.

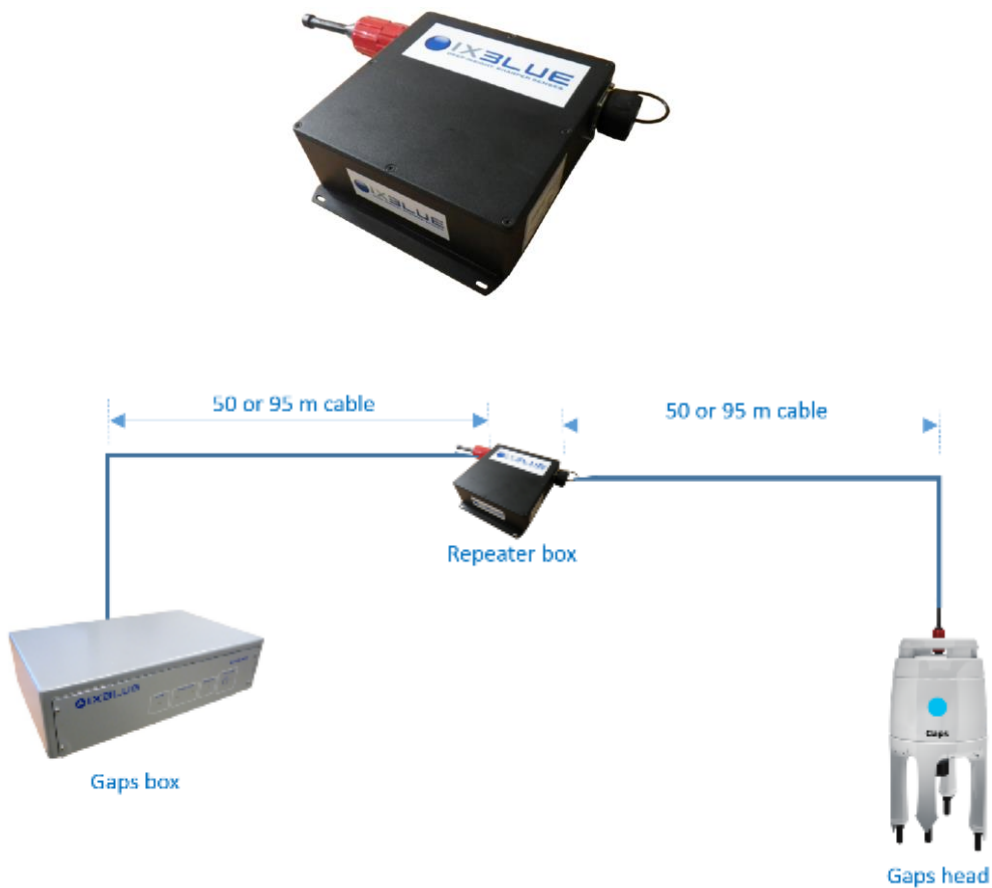

Gaps repeater box when cable length higher than 95 m

SPECIFICATION	
Dimension (L x l x h)	217 x 188 x 68.5 mm
Weight	2.15 kg
Operating temperature ⁽¹⁾	-5°C to +50°C
Temperature, storage ⁽¹⁾	-20 °C to +80 °C
IP rating	IP65

(1) NF X10-812

11 Gaps specification

11.1 System (Gaps + cable + box)

POSITIONING ACCURACY ⁽²⁾	CEP50	CEP90
SNR ⁽³⁾ = 0 dB	0.53% x slant range	1.06% x slant range
SNR ⁽³⁾ = 10 dB	0.17% x slant range	0.34% x slant range
SNR ⁽³⁾ = 20 dB	0.06% x slant range	0.12% x slant range

(2) In vertical conditions. With MT9x2 beacon. Transmit level = 191 dB ref μPa @ 1 m, sound velocity compensated, slant range of 1000 m

(3) SNR is input signal to noise ratio

RANGE/BEARING ACCURACY ⁽⁴⁾	RMS/STD DEV/1 sigma (68%)	2 sigma (95%)
SNR = 0 dB	0.02 m / 0.30°	0.04 m / 0.60°
SNR = 10 dB	0.02 m / 0.09°	0.04 m / 0.18°
SNR = 20 dB	0.02 m / 0.03°	0.04 m / 0.06°

(4) In vertical conditions. Responder mode.

PERFORMANCE	
Range ⁽⁵⁾	4 000 m
Coverage	200 deg below acoustic array
Operating frequency	21.7 – 30.3 kHz wideband
Position refresh rate	1 to 15 s (depends on range) – 10 Hz with predictive filter 1 s when ping stacking activated (whatever the range)
Nb of channels	8 with MT8 beacons 40 with MT9 beacons 529 with MTA beacons
Acoustic transmit level	191 dB \pm 3 dB ref. 1 μPa @ 1 m

(5) For a surface noise level below 67 dB ref μPa . Transponder transmit level = 191 dB ref. 1 μPa @ 1 m. Vertical conditions. With MT9x2 beacons.

INERTIAL NAVIGATION SYSTEM	
Position accuracy	Three times better than GNSS accuracy
No aiding for 2 min / 5 min	3 m / 20 m (CEP50)
Pure inertial mode	0.6 nm / hour (CEP50)
Heading accuracy with GNSS	0.01 deg sec. lat. (RMS)
Roll, pitch	0.01 deg (RMS)
Heave accuracy (Smart heave)	2.5 cm or 2.5% RMS

ACOUSTIC COMMUNICATION	
Sequencing	Simultaneous positioning and communication
Type	Bi-directional (Gaps head to beacon and beacon to Gaps head=
Data rate	500 bps (160 bits per recurrence)
Doppler	± 6 knots
Surface input/output	Ethernet or serial link (broadcast from/to host)
Underwater input/output	Serial link (broadcast from/to host)

INPUT / OUPUT	
Control / command	Ethernet with WEB-based user interface
Input/output (serial)	4 communication ports (RS232 / 422 / 485)
Baud rate (serial)	1.2 to 115 kbauds
Input/output (Ethernet)	4 communication ports (UDP / TCP client / TCP server)
Synchronization IN	1 PPS and 1 external trigger
Synchronization OUT	2 triggers
Input/output formats	Industry standards: NMEA 0183, ASCII, BINARY

MTBF	
MTBF	> 10 000 h (Based on in-the-field repair statistics)

11.2 Gaps head

MECHANICAL	
Dimension (Ø x h)	296 x 638 mm (without connector)
Minimum gate valve	300 mm / 12"
Weight (air/water)	16 kg / -7 kg (positive buoyancy)
Depth rating	25 m (standard) / 100 m (non destructive)
Construction	Carbon fiber painted
Maximum sailing speed	12 knots
Connector	Subconn MCOMM21F

ENVIRONMENTAL	
Temperature, operating⁽⁶⁾	-5 to +35°C
Temperature, storage⁽⁶⁾	-40 to +70°C
Thermal shock⁽⁶⁾	Δ 45°C
Vibration⁽⁶⁾	1 to 55 Hz ± 1 mm / 10 m/s ²
Shock⁽⁶⁾	15 m/s ² / 15 ms / ½ sinus
EMC	89 / 336 / EEC – EN 60945

(6) NF X10-812

11.3 Gaps BOX

MECHANICAL	
Dimension (L x l x h)	361 mm x 233 mm x 93.5 mm
Weight	4.6 Kg
IP rating	IP51

ENVIRONMENTAL	
Temperature, operating ⁽⁷⁾	-5 to +50°C
Temperature, storage ⁽⁷⁾	-40 to +80°C
Humidity ⁽⁷⁾	95% at 40°C
Vibration ⁽⁷⁾	1 to 55 Hz ± 1 mm / 10 m/s ²
Shock ⁽⁶⁾	15 m/s ² / 15 ms / ½ sinus
EMC	EN 60950 / EN 61000

(7) NF X10-812

11.4 Main cable

CABLE BETWEEN GAPS HEAD AND GAPS BOX	
Length	50 m ± 1.5 m (option for 95 m ± 3 m and for repeater box when greater ranges are required)
ATEX	Yes (option)
Diameter	15 mm (±0.8 mm) – 42 mm for the Subconn connector
Minimum bending radius	75 mm
Maximum pulling strength	150 daN

12 Gaps performances

12.1 Maximum range

The maximum range that can reach the system is driven by the sonar equation and the signal to noise ratio:

$$SNR = [TL - 20 \log D - a_0 D + 10 \log(B_{signal} T)] - [NIS + 10 \log B_{noise}]$$

With:

- SNR : signal to noise ratio in dB
- TL : transmit level in dB / sqrt(Hz) @ 1 m ref μPa
- D : slant range in m
- a₀ : attenuation in dB/km
- B_{signal} : signal bandwidth in Hz
- B_{noise} : input signal bandwidth in Hz
- T : pulse duration in s
- NIS : noise level in dB / sqrt(Hz) @ 1 m ref μPa

Above formula enables to estimate maximum ranges that enables a sufficient signal to noise ratio for the detection, depending on the conditions (noise level).

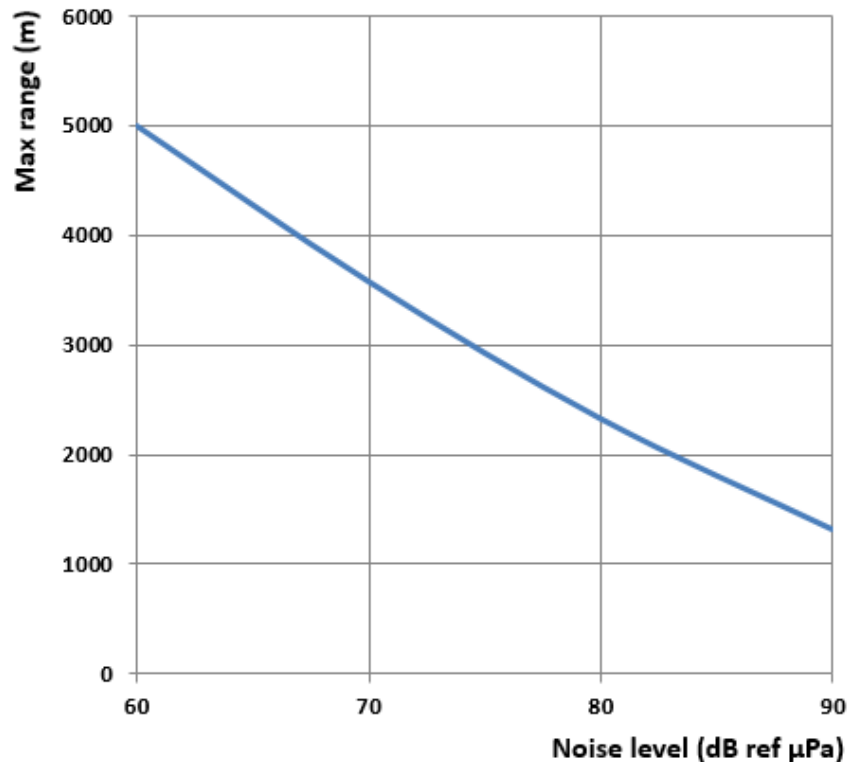

Maximum range depending on noise level for a transmit level of 191 dB ref μPa @ 1 m and a MT8/9, at 1 000 m

12.2 Bearing accuracy

For the acoustic part of the global budget of error, the bearing accuracy is given by the Woodard formula (accuracy on bearing for a goniometer).

$$\delta\theta = \frac{\lambda}{\pi p \cdot \sin\theta \cdot \sqrt{2 \cdot SNR}}$$

With:

- λ : wavelength in m
- P : distance between hydrophones in m
- θ : target angle in rad
- SNR: signal to noise ratio $10^{(\text{value in dB} / 10)}$

Following graphic provides bearing accuracy for a beacon in responder mode, at 1000 m of slant range, in vertical conditions, for different noise levels.

12.3 Positioning accuracy

Unlike other conventional USBL system the performance is inclusive of all sources of error such as GNSS (DGNSS mode), motion and heading internal sensors. The global budget of error is the quadratic sum of each error that are supposed to be independent.

Following graphic provides positioning accuracy for a MT8/9 beacon in responder mode, in vertical conditions, for different SNR_in. It includes a GNSS error of 10 cm.

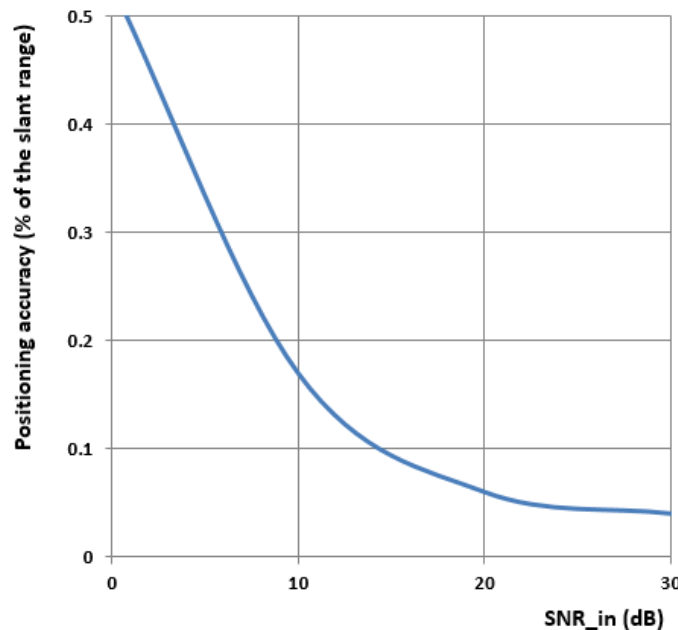

Positioning accuracy depending on SNR_in – CEP 50

12.4 Maximum range depending on beacons

Below table and graphic present exact maximum ranges figures for the different models of compatible beacons.

Noise level (dB ref μPa)	MT832 and MT932 ⁽¹⁾	ZTA02C	AAE 1219A and 1319A ⁽²⁾	AAE 1019 ⁽²⁾	AAE 1065 ⁽²⁾	Sonardyne Wideband™1 192 dB ref 1 μPa @ 1 m ⁽³⁾
60	5000 m	1500 m	3450 m	4135 m	6380 m	4520 m
70	3580 m	1500 m	2220 m	2800 m	4850 m	3150 m
80	2330 m	1500 m	1230 m	1690 m	3450 m	1965 m
90	1320 m	1000 m	570 m	860 m	2215 m	1050 m

(1) Transmit level is high setting

(2) iXblue reply code

(3) Requires Sonardyne Wideband™1 option, Beacons in responder mode

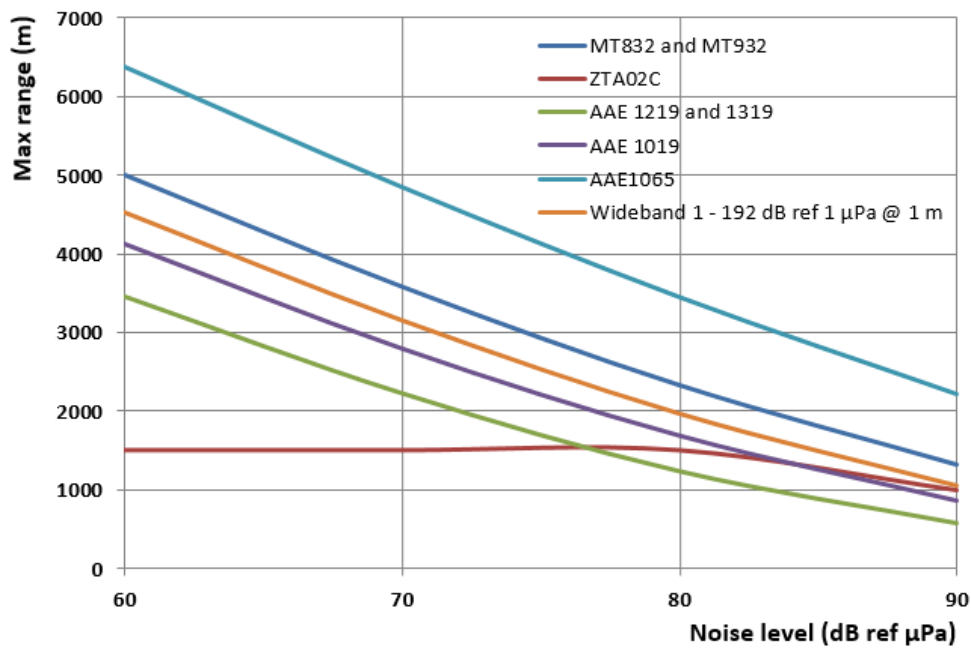

Maximum range depending on noise level and type of beacon

12.5 Positioning accuracy depending on beacons

Following table provides positioning accuracy for a beacon in responder mode, at 1000 m of slant range, in vertical conditions, for different noise levels and a GNSS with a 10 cm accuracy.

Noise level (dB ref μPa)	MT832 and MT932 ⁽¹⁾	ZTA02C	AAE 1219A and 1319A ⁽²⁾	AAE 1019 ⁽²⁾	AAE 1065 ⁽²⁾	Sonardyne Wideband™1 192 dB ref 1 μPa @ 1 m ⁽³⁾
60	0.33 m	0.46 m	0.96 m	0.56 m	0.22 m	0.44 m
70	0.86 m	1.34 m	2.97 m	1.68 m	0.36 m	1.24 m
80	2.65 m	4.19 m	9.38 m	5.28 m	0.96 m	3.87 m
90	8.36 m	13.25 m	No detec.	No detec.	2.97 m	12.21

(1) Transmit level is high setting

(2) ixblue reply code

(3) Requires Sonardyne Wideband™1 option, CEP50

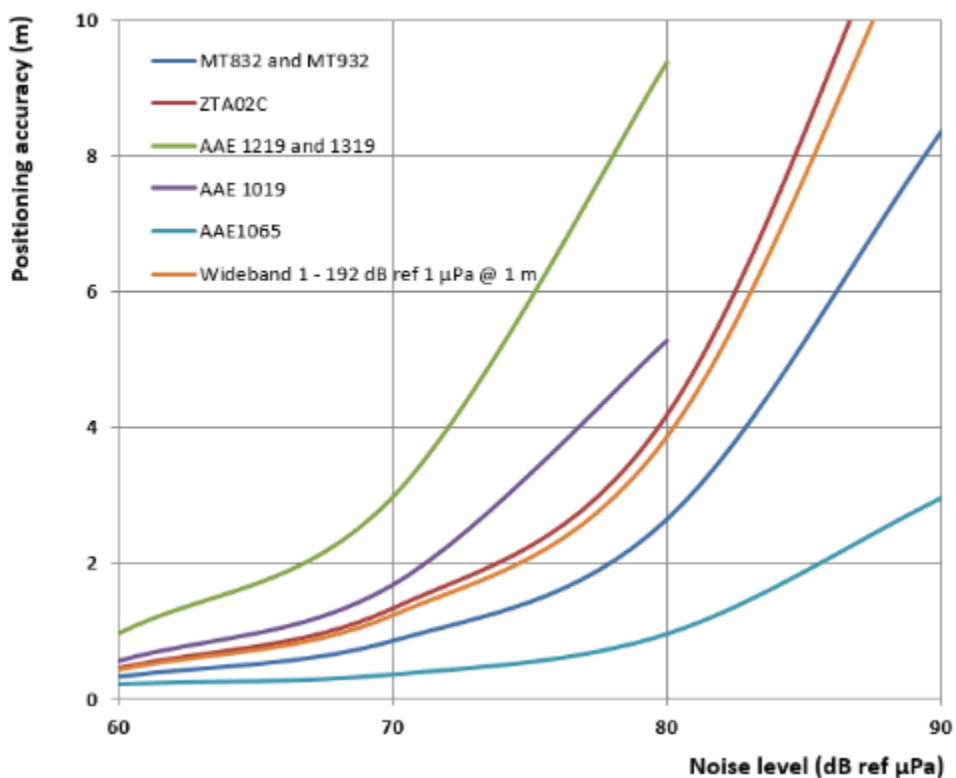

Positioning accuracy depending on noise level and type of beacon - CEP 50

12.6 Positioning accuracy depending on elevation

Unless Gaps acoustic antenna is designed to have excellent performances in horizontal tracking and due to acoustic propagation, the performances for high elevation angles is less than in vertical conditions. The positioning accuracy, depending on vertical angle can be estimated as below:

Vertical angle	MT832 and MT932 ⁽¹⁾
0 deg	0.06 % of the S.R.
30 deg	0.06 % of the S.R.
60 deg	0.10 % of the S.R.
90 deg	0.30 % of the S.R.

(1) SNR_{in} = 20 dB ref μPa, CEP50

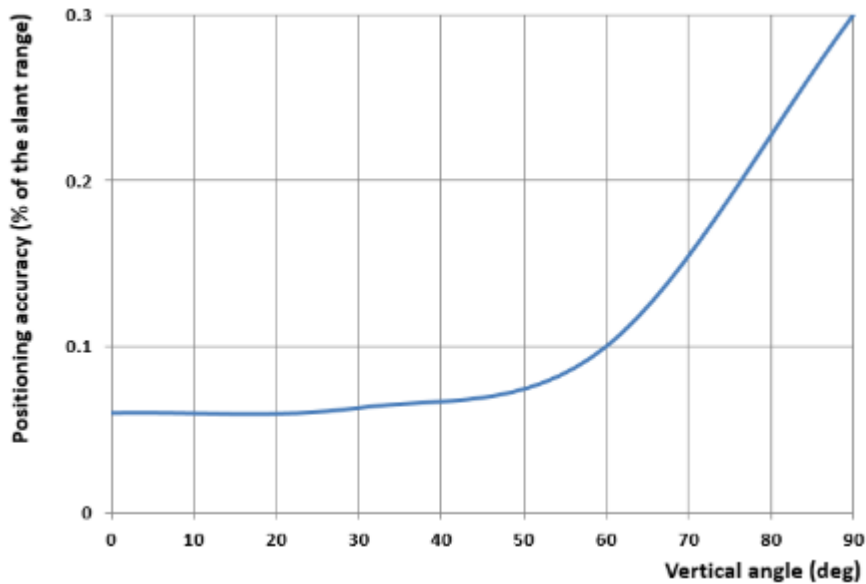

**Positioning accuracy depending on vertical angle
(0 deg is vertical, 90 deg is horizontal) – CEP 50**

12.7 Performances for Dynamic Positioning

Dynamic Positioning requires to deploy fixed beacon on the seabed and calibrate it. Several BOX-IN methods or vessel trajectories can be used to accurately determine the position of the fixed transponders that will be used for the DP. The Gaps software provides the position for each beacon when BOX-IN is finished:

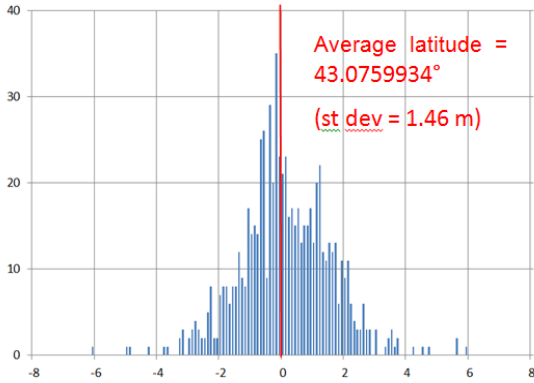

Distribution of raw latitude (m) – Water depth 1000 m

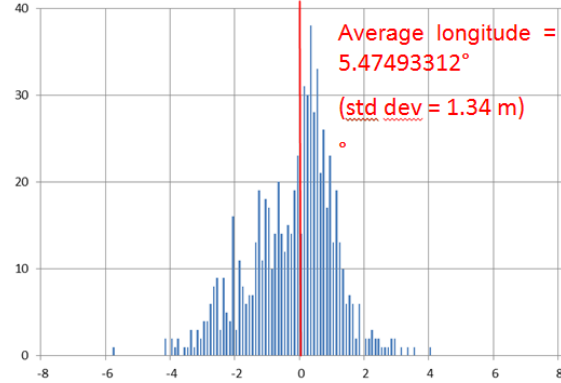

Distribution of raw longitude (m) –Water depth 1000 m

The following table presents theoretical surface positioning accuracy in the 3 different modes (USBL, L/USBL and L/USBL/INS).

	Positioning accuracy for the vessel (water depth = 500 m)		
Nb of transponder	USBL	LBL	L/USBL/INS
1 transponder	0.95 m	N.A.	0.31 m
2 transponders	0.67 m	N.A.	0.22 m
3 transponders	0.55 m	0.43 m	0.14 m
5 transponders	0.43 m	0.33 m	0.11 m
10 transponders	0.30 m	0.23 m	0.08 m

Fixed transponders are placed in order to give maximum observability for surface positioning

Vessel position is centred into the field of transponders

Size of the subsea array (distance between subsea fixed transponders) is in same order of magnitude than water depth

USBL SNR = 30 dB, N = 100 (number of USBL recurrences for the calibration of fixed transponders)

12.8 Obtained performances in shallow water (vertical conditions)

Conditions

- Location: La Ciotat Bay, South of France
- Data logged into January 2016
- Water depth is 46 m
- Two beacons are clamped onto a rope and are deployed above the seabed with buoyancy (beacons are not supposed to move)
- Gaps is deployed from a surface vessel equipped with RTK GNSS (0.1 m accuracy)
- Vessel is drifting with the wind and the current above the beacon
- The horizontal distance is varying from 0 to 20 m
- Logging duration: 5 mn
- Positioning recurrence: 2 s (150 USBL fix per beacon)
- Beacon model: ZTA02C
- Gaps model: Gaps IV
- Sound velocity measured and configured into the Gaps
- No pressure sensor on the beacon



Beacons deployment



Vessel used for the trials



Location of the trials

Lat/Long graph

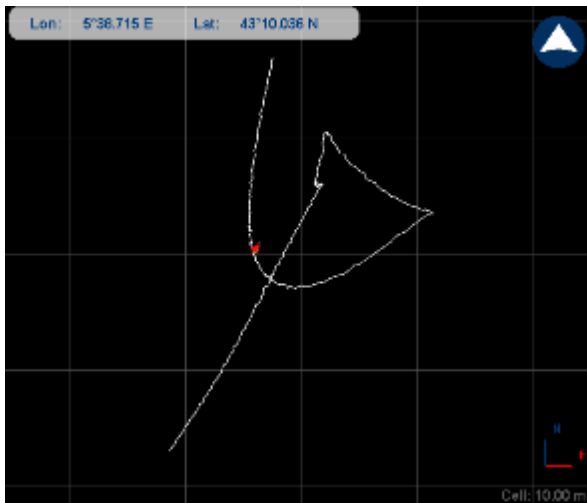

Global vessel trajectory (white) and beacons positions (red and green) – grid is 10 m

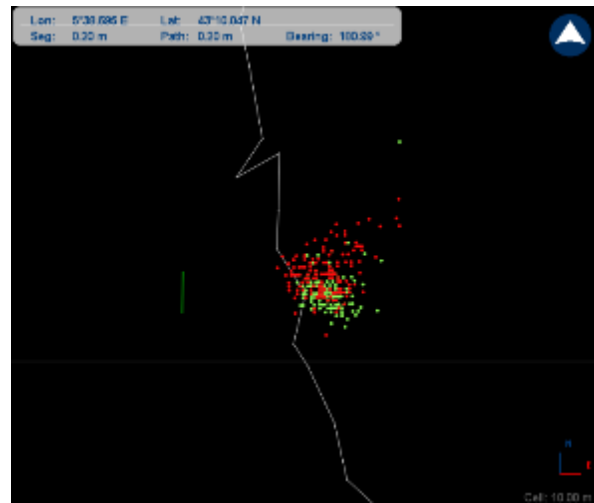

**Green dots : beacon ID 2
Red dots : beacon ID 1
Green line: 0.2 m (for information)**

Lat/Long graph versus time



Latitude, longitude and depth graph (versus time) for beacon ID 1

	Beacon ID 1	Beacon ID 2
Latitude std dev	0.11 m	0.09 m
Longitude std dev	0.12 m	0.08 m
Depth std dev	0.03 m	0.03 m
CEP-50	0.10 m	0.07 m

12.9 Obtained performances in shallow water (horizontal tracking)

Conditions

- Location: La Ciotat Bay, South of France
- Data logged into March 2012
- Water depth is 50 m
- A beacon is clamped onto a rope and are deployed above the seabed with buoyancy (beacons is not supposed to move)
- Gaps is deployed from a surface vessel equipped with RTK GNSS (0.1 m accuracy)
- Vessel is sailing around the beacons and horizontal distance is increased
- Gaps model: Gaps III
- Sound velocity measured and configured into the Gaps
- No pressure sensor on the beacon
- Noise level: 86 dB ref μPa
- Average SNR_{in}: 10 dB

Horizontal range / vertical angle	Positioning accuracy (in m) CEP 50	Positioning accuracy (in % of the S.R.) CEP 50
50 m / 45 deg	0.11 m	0.16%
100 m / 63 deg	0.22 m	0.20%
150 m / 72 deg	0.36 m	0.23%
200 m / 76 deg	0.56 m	0.27%
250 m / 79 deg	0.62 m	0.24%
300 m / 80 deg	0.67 m	0.22%

13 Life cycle

13.1 Packaging, Handling, Storage, Transportation requirements

During storage and transportation, Gaps and its accessories should be kept locked in its transportation case. The whole system is packed in two reusable transit cases for the Gaps and its accessories and a plywood transit case for the transponder only:

Important note: Gaps is a dual use product that require authorization if leaving European Community.

13.2 Calibration

Because the INS and the acoustic parts are built in the same housing, there is no need to recalibrate the system periodically. The calibration is only required following hydrophones/legs replacement, when user needs nominal positioning accuracy.

13.3 Built-in test

Gaps includes a Continuous Built-In Test (CBIT) that covers internal sensor status verification, system status and algorithm status. The User Manual document details the complete list of parameters that are monitored.

13.4 Reliability & maintainability

Subconn recommends a replacement of the 24-pins connector every 4 years to avoid any water ingress. But thanks to the technology used in its design, Gaps does not require any kind of preventive maintenance except regular visual inspections for permanent installations, under vessel hulls to check for marine growth.

13.5 Hydrophone/leg replacement

Hydrophones and short/long legs can be ordered separately as spare parts and replaced on the field.













A new hydrophone design to protect Gaps mechanical structure in case of an incident:











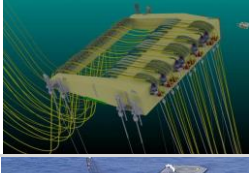

- One connector only
- Longer cable providing more freedom to the damaged part
- One single design for all hydrophones
- Breakable sections in the lead cable to protect connector in case of traction or flexion

To reach nominal performances after a hydrophone/leg replacement, a calibration must be performed. This requires to deploy a fixed beacon on the seabed (100 m to 1000 m of water depth), sail around the beacon and use a dedicated calibration software which is provided with the system.

14 References

The main customers are rental companies, offshore companies, military and scientific institutes.

<p>ALDA MARINE (France)</p>	<p>Submarine cable deployment</p>	
<p>ASHTEAD (UK)</p>	<p>Rental company</p>	
<p>Belgian Navy (Belgium)</p>	<p>Mine Counter Measure Vehicle : Double Eagle</p>	
<p>BOSKALIS (Netherlands)</p>	<p>Dredging, construction, survey</p>	
<p>C&C Technology (USA)</p>	<p>Survey. Vehicle: C-Surveyor I</p>	
<p>COSL (China)</p>	<p>Survey</p>	
<p>COMRA (China)</p>	<p>Oceanographic Institute ROV and AUV positioning Dynamic Positioning</p>	
<p>DE BEERS (South Africa)</p>	<p>Subsea mining Drill head positioning</p>	
<p>FUGRO (Netherlands)</p>	<p>Survey. Vehicle: Echo Surveyor II</p>	
<p>IFREMER (France)</p>	<p>ROV and AUV positioning Dynamic Positioning</p>	
<p>ISE (Canada)</p>	<p>AUV tracking</p>	

<p>JOGMEC (Japan)</p>	<p>Drilling, mining, ROV positioning</p>	
<p>MARUM (Germany)</p>	<p>Research University ROV tracking</p>	
<p>MMTAB (Sweden)</p>	<p>Multibeam survey with tow fish</p>	
<p>NIOT (India)</p>	<p>Oceanographic Institute</p>	
<p>P&O Maritime (Ireland)</p>	<p>ROV positioning and Dynamic Positioning</p>	
<p>Petrobras / Cybernetix (Brazil)</p>	<p>Buoyancy supported riser (BSR) monitoring system</p>	
<p>SAIPEM (France)</p>	<p>Pipe laying and subsea construction</p>	
<p>SBGS (USA / Norway)</p>	<p>Ocean Bottom Cable</p>	
<p>Seatronics (UK)</p>	<p>Rental company</p>	
<p>ST Electronics (Singapore)</p>	<p>Mine sweeping</p>	
<p>STR (UK)</p>	<p>Rental company</p>	
<p>Unique Systems (USA)</p>	<p>Rental company</p>	
<p>Van Oord (Netherlands)</p>	<p>Multi purpose vessels to install cables for wind farm</p>	

15 Drawings

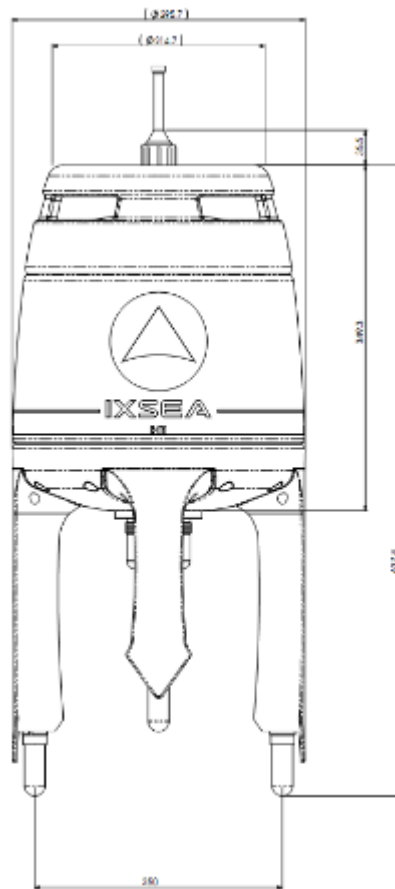

Gaps overall dimensions

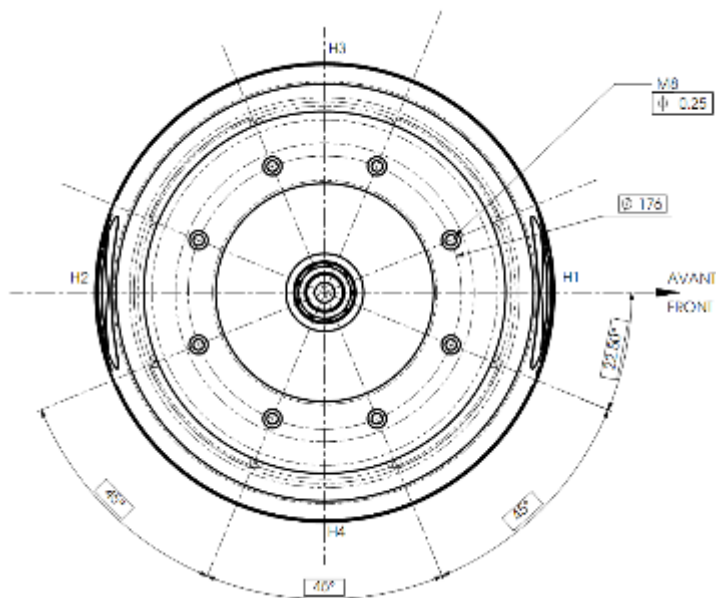

Gaps top flange

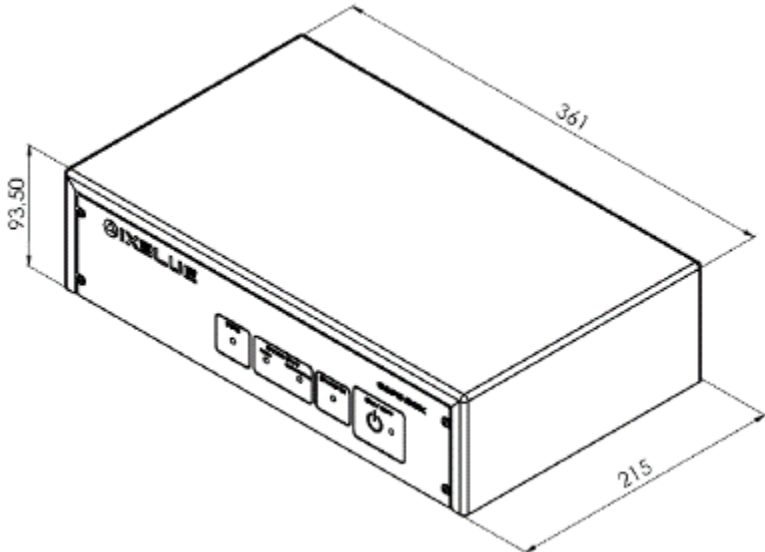

Gaps box overall dimensions