



USER GUIDE

Trimble® SPSx61 Modular GPS Heading Receivers



USER GUIDE

Trimble® SPSx61 Modular GPS Heading Receivers

Version 3.84
Revision B
March 2009



Corporate Office

Trimble Navigation Limited
935 Stewart Drive
Sunnyvale, CA 94085
USA
www.trimble.com

Construction Business Area

Trimble Navigation Limited
Construction Business Area
5475 Kellenburger Road
Dayton, Ohio 45424-1099
USA

800-538-7800 (toll free in USA)

+1-937-245-5600 Phone

+1-937-233-9004 Fax

www.trimble.com

E-mail: trimble_support@trimble.com

Legal Notices

© 2006–2009, Trimble Navigation Limited. All rights reserved.

Trimble, and the Globe & Triangle logo are trademarks of Trimble Navigation Limited, registered in the United States Patent and Trademark Office and in other countries. AutoBase, CMR, CMRx, CMR+, HYDRO^{pro}, Maxwell, Micro-Centered, TGO, SiteNet, TRIMMARK, TRIMTALK, TSC2, TSCe, VRS, Zephyr, and Zephyr Geodetic are trademarks of Trimble Navigation Limited.

The Bluetooth word mark and logos are owned by the Bluetooth SIG, Inc. and any use of such marks by Trimble Navigation Limited is under license.

Microsoft, Windows, and Windows NT are either registered trademarks or trademarks of Microsoft Corporation in the United States and/or other countries.

All other trademarks are the property of their respective owners.

Release Notice

This is the March 2009 release (Revision B) of the *SPSx61 Modular GPS Heading Receivers User Guide*. It applies to version 3.84 of the receiver firmware.

Product Limited Warranty Information

For applicable product Limited Warranty information, please refer to the Limited Warranty Card included with this Trimble product, or consult your local Trimble authorized dealer.

Notices

Class B Statement – Notice to Users. This equipment has been tested and found to comply with the limits for a Class B digital device, pursuant to Part 15 of the FCC rules and Part 90. These limits are designed to provide reasonable protection against harmful interference in a residential installation. This equipment generates, uses, and can radiate radio frequency energy and, if not installed and used in accordance with the instructions, may cause harmful interference to radio communication. However, there is no guarantee that interference will not occur in a particular installation. If this equipment does cause harmful interference to radio or television reception, which can be determined by turning the equipment off and on, the user is encouraged to try to correct the interference by one or more of the following measures:

- Reorient or relocate the receiving antenna.
- Increase the separation between the equipment and the receiver.
- Connect the equipment into an outlet on a circuit different from that to which the receiver is connected.
- Consult the dealer or an experienced radio/TV technician for help.

Changes and modifications not expressly approved by the manufacturer or registrant of this equipment can void your authority to operate this equipment under Federal Communications Commission rules.

Canada

This Class B digital apparatus complies with Canadian ICES-003. Cet appareil numérique de la classe B est conforme à la norme NMB-003 du Canada.

This apparatus complies with Canadian RSS-GEN, RSS-310, RSS-210, and RSS-119.

Cet appareil est conforme à la norme CNR-GEN, CNR-310, CNR-210, et CNR-119 du Canada.

Europe

This product (the SPSx61 Modular GPS receiver) is intended to be used in all EU member countries, Norway, and Switzerland.



This product has been tested and found to comply with the requirements for a Class B device pursuant to European Council Directive 89/336/EEC on EMC, thereby satisfying the requirements for CE Marking and sale within the European Economic Area (EEA). Contains Bluetooth radio module PBA 31308. These requirements are designed to provide reasonable protection against harmful interference when the equipment is operated in a residential or commercial environment. The 450 MHz (PMR) bands and 2.4 GHz are non-harmonized throughout Europe.

Australia and New Zealand

This product conforms with the regulatory requirements of the Australian Communications Authority (ACA) EMC framework, thus satisfying the requirements for C-Tick Marking and sale within Australia and New Zealand.



Notice to Our European Union Customers

Directive 1999/5/EC

Hereby, Trimble Navigation, declares that the SPSx61 Modular GPS receivers are in compliance with the essential requirements and other relevant provisions of Directive 1999/5/EC.

Restriction of Use of Certain Hazardous Substances in Electrical and Electronic Equipment (RoHS)

This Trimble product complies in all material respects with DIRECTIVE 2002/95/EC OF THE EUROPEAN PARLIAMENT AND OF THE COUNCIL of 27 January 2003 on the restriction of the use of certain hazardous substances in electrical and electronic equipment (RoHS Directive) and Amendment 2005/618/EC filed under C(2005) 3143, with exemptions for lead in solder pursuant to Paragraph 7 of the Annex to the RoHS Directive applied.

Waste Electrical and Electronic Equipment (WEEE)

For product recycling instructions and more information, please go to www.trimble.com/ev.shtml.

Recycling in Europe: To recycle Trimble WEEE (Waste Electrical and Electronic Equipment, products that run on electrical power.), Call +31 497 53 24 30, and ask for the "WEEE Associate". Or, mail a request for recycling instructions to:



Trimble Europe BV
c/o Menlo Worldwide Logistics
Meerheide 45
5521 DZ Eersel, NL

Declaration of Conformity

We, Trimble Navigation Limited,

935 Stewart Drive
PO Box 3642
Sunnyvale, CA 94088-3642
United States
+1-408-481-8000

declare under sole responsibility that the products:
SPSx61 Modular GPS receiver
comply with Part 15 of FCC Rules.

Operation is subject to the following two conditions:

- (1) this device may not cause harmful interference, and
- (2) this device must accept any interference received, including interference that may cause undesired operation.

Safety Information

Before you use your Trimble® SPS GPS receiver, make sure that you have read and understood all safety requirements.

Regulations and safety

The receivers contain an internal radio-modem and can send signals through Bluetooth® wireless technology. Bluetooth 900 MHz radio-modems operate in license-free bands.

Before operating an SPSx61 Modular GPS Heading receiver, determine if authorization or a license to operate the unit is required in your country. It is the responsibility of the end user to obtain an operator's permit or license for the receiver for the location or country of use.

For FCC regulations, see [Notices, page 2](#).

Type approval

Type approval, or acceptance, covers technical parameters of the equipment related to emissions that can cause interference. Type approval is granted to the manufacturer of the transmission equipment, independent from the operation or licensing of the units. Some countries have unique technical requirements for operation in particular radio-modem frequency bands. To comply with those requirements, Trimble may have modified your equipment to be granted Type approval. Unauthorized modification of the units voids the Type approval, the warranty, and the operational license of the equipment.

Exposure to radio frequency radiation

- **DO NOT** operate the equipment near electrical blasting caps or in an explosive atmosphere.
- All equipment must be properly grounded according to Trimble installation instructions for safe operation.
- All equipment should be serviced only by a qualified technician.

For Bluetooth radio

The radiated output power of the internal Bluetooth wireless radio is far below the FCC radio frequency exposure limits. Nevertheless, the wireless radio shall be used in such a manner that the Trimble receiver is 20 cm or further from the human body. The internal wireless radio operates within guidelines found in radio frequency safety standards and recommendations, which reflect the consensus of the scientific community. Trimble therefore believes that the internal wireless radio is safe for use by consumers. The level of energy emitted is far less than the electromagnetic energy emitted by wireless devices such as mobile phones. However, the use of wireless radios

may be restricted in some situations or environments, such as on aircraft. If you are unsure of restrictions, you are encouraged to ask for authorization before turning on the wireless radio.

Installing antennas



CAUTION – For your own safety, and in terms of the RF exposure requirements of the FCC, always observe these precautions:

- Always maintain a minimum separation distance of 20 cm (7.8 inches) between yourself and the radiating antenna.
 - Do not co-locate the antenna with any other transmitting device.
-



CAUTION – The GPS antenna and its cabling should be installed in accordance with all national and local electrical codes, regulations, and practices.

The antenna and cabling should be installed where they will not become energized as a result of falling nearby power lines, nor be mounted where they are subjected to overvoltage transients, particularly lightning. Such installations require additional protective means that are detailed in national and local electrical codes.

This device has been designed to operate with the antennas listed below. Antennas not included in this list are strictly prohibited for use with this device. The required antenna impedance is 50 ohms.

The antennas that can be used (country dependent) with the **450 MHz radio** are 0 dBi and 5 dBi whip antennas. The antennas that can be used (country dependent) with the **900 MHz radio** are 0 dBi, 3 dBi, and 5 dBi whip antennas.

To reduce potential radio interference to other users, the antenna type and its gain should be so chosen so that the equivalent isotropically radiated power (e.i.r.p.) is not more than that permitted for successful communication.

Wet locations



WARNING – This product is not intended to be used outdoors or in a wet location when it is powered by the Power over Ethernet (POE) interface, or by the external power supply.



WARNING – The external power adapter and its associated power cord and plug are not intended to be installed outdoors, or in a wet location.

Use of Power over Ethernet



WARNING – When this product is connected to a Power over Ethernet connection, the source of the Ethernet power must meet IEEE 802.11af, and its DC output (Ethernet power source) must be completely isolated from earth ground (floating), or a shock hazard may exist.

Contents

	Safety Information	3
	Regulations and safety	3
	Type approval	3
	Exposure to radio frequency radiation	3
	For Bluetooth radio	3
	Installing antennas	4
	Wet locations.	4
	Use of Power over Ethernet.	4
1	Introduction	9
	About the SPSx61 receivers.	9
	SPS361 GPS Heading receiver	9
	SPS461 GPS Heading receiver	9
	Related information	10
	Technical support.	10
	Your comments	10
2	Features and Functions	11
	SPS361 and SPS461 features	12
	SPS361 receiver optional features.	12
	SPS461 receiver optional features.	13
	Rover	13
	Use and care	13
	COCOM limits	14
	Keypad and display.	14
	Rear connectors	15
3	Batteries and Power	17
	External power	18
	Power over Ethernet (PoE)	18
4	Setting up the Receiver	19
	Rover operation guidelines	20
	Rover receiver components	20
	Rover receiver setup guidelines	20
	Setting up the SPSx61 GPS receivers to provide heading	23
	Installing the receiver	23
	Mounting the antennas	23
	Interfacing using the NMEA protocol	24
	Heading output	24
5	Configuring the Receiver Using the Keypad and Display	25
	Button functions	26

Power button operations	26
Home screen	27
Status screens	28
Radio status	28
Configuring the receiver as a rover receiver	29
Configuring the receiver using the keypad	29
Configuring Ethernet settings	31
Configuring system settings	31
Managing application files	33
6 Configuring the Receiver Using the Web Browser Interface	35
Ethernet settings	36
Configuring the receiver using a web browser	37
Supported browsers	37
Connecting to the receiver using a web browser	37
Connecting to the receiver using a web browser and Bluetooth wireless technology	38
Creating a new connection.	42
Menus	46
Changing the settings	46
7 Default Settings	59
Default receiver settings	60
Resetting the receiver to factory defaults	60
8 Specifications.	61
Configuration options	62
General specifications	62
Antenna options.	62
Temperature	62
Shock and vibration	63
Measurements	63
Positioning	63
Initialization time.	64
Power	64
Regulatory approvals.	64
Communications	64
Notes.	65
Signal tracking.	65
Variable configuration options.	66
Upgrading the receiver	66
A NMEA-0183 Output.	67
NMEA-0183 message overview	68
Common message elements	69
Message values	69

NMEA messages	69
PTNL,GGK	78
B GSOF Messages	87
Supported message types	88
General Serial Output Format	88
Reading binary values	89
INTEGER data types	89
GSOF message definitions	91
TIME	92
LLH	92
ECEF	93
ECEF DELTA	93
TPlane ENU	93
Velocity	94
PDOP	95
SIGMA	95
SV Brief	96
SV Detail	96
UTC	97
Batt/Mem	98
Attitude	98
BASE POSITION AND QUALITY INDICATOR	99
Flags	100
C Adding UHF Internal Radio Frequencies	103
Adding receive frequencies for the 450 MHz internal receive radio	104
Setting UHF reception radio frequencies using the web interface	105
D Real-Time Data and Services	107
Login authentication	108
E Upgrading the Receiver Firmware	109
The WinFlash utility	110
Installing the WinFlash utility	110
Upgrading the receiver firmware	110
Forcing the receiver into Monitor mode	111
F Troubleshooting	113
Receiver issues	114
G Drawings	117
Back view	118
Side view	118

H	Receiver Connector Pinout Information	119
	Modem multi-function port	120
	1PPS and ASCII time tag	121
	ASCII time tag	122
	26-Pin D-sub connector wiring chart (P/N 60789-00)	123
	26-Pin D-sub connector wiring chart (P/N 65791-00)	124
	Glossary	125

Introduction

Welcome to the SPSx61 Modular GPS Heading Receivers User Guide. This manual describes how to set up and use the Trimble® SPSx61 Modular GPS receivers.

About the SPSx61 receivers

The SPSx61 Modular GPS receiver family comprises the following receivers:

- SPS361
- SPS461

The SPS461 receiver can be ordered with options or upgraded post-sale to the following levels of position accuracy:

- Location RTK
- Location RTK with Precise Vertical
- Precise RTK

SPS361 GPS Heading receiver

The Trimble SPS361 is a dual-frequency GPS Heading receiver available with or without an internal MSK Beacon receiver. The SPS361 receiver is capable of DGPS positioning accuracies using any of the following differential correction sources:

- Satellite-Based Augmentation Systems (SBAS) corrections (WAAS/EGNOS/MSAS)
- DGPS RTCM corrections from the internal MSK Beacon receiver

- DGPS RTCM corrections from an external source
- RTK corrections from an external source (solution is limited to DGPS precision)
- OmniSTAR VBS correction service from an internal demodulator
- OmniSTAR VBS correction service from an external source

The SPS361 receiver can only be used as a rover receiver and it cannot be used as a DGPS RTCM base station or upgraded.

The SPS361 receiver is shipped as a complete system with GA530 antennas and cables.

SPS461 GPS Heading receiver

The Trimble SPS461 is a dual-frequency GPS Heading receiver, which provides DGPS accuracy position from SBAS, OmniSTAR VBS, MSK Beacon, or external RTCM DGPS corrections. Using a pair of dual-frequency antennas, the SPS461 GPS Heading receiver computes the precise vector between the two antenna phase centers to provide a heading with the option of either pitch or roll for precise platform, vehicle, or vessel orientation.

The SPS461 is available with the following hardware configurations:

- No internal radio
- MSK Beacon internal receiver
- 450 MHz internal receive-only radio combined with MSK Beacon internal receiver

- 900 MHz internal receive-only radio

The SPS461 kits do not include the GPS antennas or antenna cables, which must be ordered separately. The following GPS antennas are supported:

- GA530
- GA510
- Zephyr™ Model 2
- Rugged Zephyr Model 2

All SPSx61 GPS Heading receivers provide the same precise heading capability. However, you can upgrade the SPS461 receiver to provide different levels of positioning accuracies:

- Location RTK
- Location RTK with Precise Vertical
- Precise RTK

Location RTK option

The Location RTK option adds the 10 cm Horizontal and Vertical precision capability when using RTK corrections.

Location RTK with Precise Vertical option

The Location RTK with Precise Vertical option adds the 2 cm Vertical precision capability when using RTK corrections. This option is ideal for most marine applications that require a cost effective solution with the highest vertical precision possible.

Precise RTK option

The Precise RTK option adds full RTK horizontal and vertical precision.

Related information

Sources of related information include the following:

- Release notes – The release notes describe new features of the product, information not included in the manuals, and any changes to the manuals. They can be downloaded from the Trimble website (www.trimble.com/support.shtml).
- Trimble training courses – Consider a training course to help you use your GPS system to its fullest potential. For more information, go to the Trimble website at www.trimble.com/training.html.

Technical support

If you have a problem and cannot find the information you need in the product documentation, contact your local dealer. Alternatively, go to the Support area of the Trimble website (www.trimble.com/support.shtml). Select the product you need information on. Product updates, documentation, and any support issues are available for download.

If you need to contact Trimble technical support, complete the online inquiry form at www.trimble.com/support_form.asp.

Your comments

Your feedback about the supporting documentation helps us to improve it with each revision. Email your comments to ReaderFeedback@trimble.com.

Features and Functions

In this chapter:

- [SPS361 and SPS461 features](#)
- [SPS461 receiver optional features](#)
- [Use and care](#)
- [COCOM limits](#)
- [Keypad and display](#)
- [Rear connectors](#)

Trimble SPSx61 Modular GPS receivers are ideal for the following site development and marine construction applications:

- RTK rover on site vehicle or marine vessel
- Site and marine rover applications using Location GPS augmentation including OmniSTAR, Location RTK, SBAS, Beacon, and DGPS RTCM

These receivers all feature a keypad and display so you can configure the receiver without using a controller or computer.

All the receivers can optionally record GPS data to the internal memory, and transfer the data over a serial or Ethernet connection.

SPS361 and SPS461 features

The receivers provide the following features:

- A flexible, modular, GPS Heading receiver that delivers precise heading and sub-meter horizontal positioning accuracy for marine and OEM applications
- Ethernet and browser interface provides remote access over the Internet or by cable for data and configuration
- Use RTCM DGPS corrections over a radio link from a local reference station or over a cellular connection from an Internet-based reference station
- Integrated Bluetooth wireless technology for cable-free configuration and operation with a computer or cell phone
- 72-channel L1 C/A Code, L1/L2 Full Cycle Carrier GPS receiver
- OmniSTAR VBS service capability
- 4-channel WAAS (Wide Area Augmentation System), EGNOS (European Geo-Stationary Navigation System), and MSAS Satellite-Based Augmentation (SBAS) compatible
- Configuration and monitoring interface through the following methods:
 - Web interface
 - Networked or peer-to-peer Ethernet
 - Integrated display and keyboard
- Compact design
- Easy-to-use menu system for rapid configuration and status checking
- Rugged, weatherproof construction with an IP67 environmental rating
- -40°C to $+65^{\circ}\text{C}$ (-40°F to $+149^{\circ}\text{F}$) operating temperature range
- 11 V DC to 28 V DC input power range, with over-voltage protection
- Power over Ethernet (PoE)
- Capable of rover operation with an Internet-based reference station
- RoHS compliant
- 1 Pulse-per-second (1PPS) output (cable P/N 60789-00 required)

SPS361 receiver optional features

- Integrated dual-channel IALA Beacon capability allows the use of free MSK Beacon correction transmissions without an extra receiver or antenna

SPS461 receiver optional features

The SPS461 is available in the following hardware configurations:

- Integrated dual-channel MSK Beacon receiver
- Internal 450 MHz (410 MHz to 470 MHz band) receive-only radio with integrated dual-channel MSK Beacon receiver
- Internal 900 MHz receive-only radio

The following options and upgrades are available for the SPS461 receiver:

- Location RTK (includes OmniSTAR XP/HP support)
- Location RTK with Precise Vertical (PV)
- Precise RTK
- Choice of external GPS antenna for base station or rover operation
- Attached or external radio antenna for rover or high-gain base station radio operation

Rover

- 5 Hz, 10 Hz, or 20 Hz measurement update rate (20 Hz maximum in Heading mode)
- Base station-free rover capability within a VRS network
- Base station-free rover capability using OmniSTAR services
- Operates as an SBAS rover when coverage is available

This receiver is ideal for contractors who operate mid-to-large size projects with machine control.

Use and care

This product is designed to withstand the rough treatment and tough environment that typically occurs in construction applications. However, the receiver is a high-precision electronic instrument and should be treated with reasonable care.



CAUTION – Operating or storing the receiver outside the specified temperature range can damage it. For more information, see [Chapter 8, Specifications](#).

COCOM limits

The U.S. Department of Commerce requires that all exportable GPS products contain performance limitations so that they cannot be used in a manner that could threaten the security of the United States. The following limitations are implemented on this product:

- Immediate access to satellite measurements and navigation results is disabled when the receiver velocity is computed to be greater than 1,000 knots, or its altitude is computed to be above 18,000 meters. The receiver GPS subsystem resets until the COCOM situation clears. As a result, all logging and stream configurations stop until the GPS subsystem is cleared.

Keypad and display

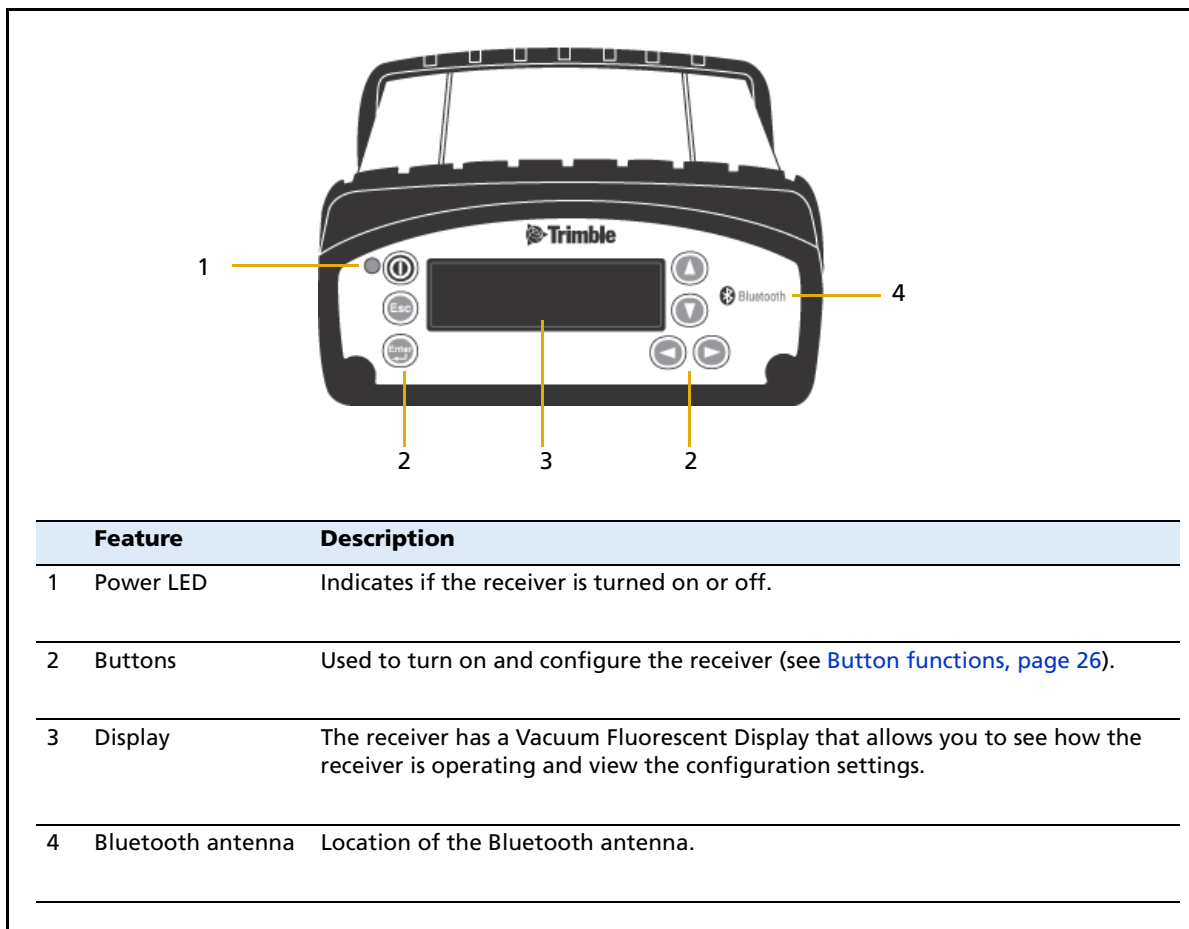

Figure 2.1 Front view of the receiver

Rear connectors

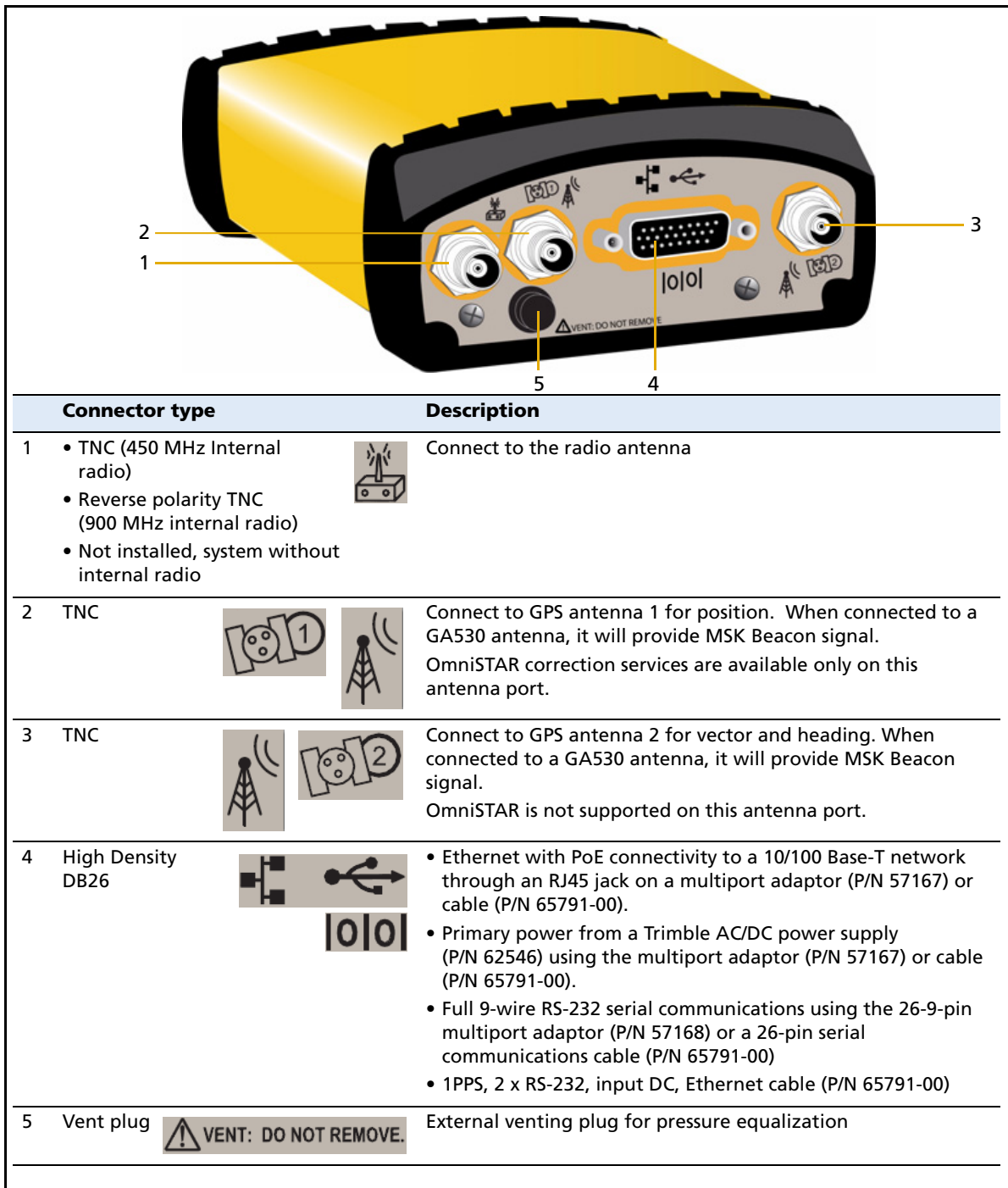

Figure 2.2 Rear view of the receiver

Batteries and Power

In this chapter:

- External power
- Power over Ethernet (PoE)

External power

The receiver is powered by an external power source using the provided cable (P/N 65791-00) connected to the 26-pin connector.

Power over Ethernet (PoE)

The receiver is a Power over Ethernet (PoE) capable device and can be powered using a single Ethernet cable from an IEEE802.3af capable network using one of the following cables/adaptors:

- 57168
- 65791-00



WARNING – This product is not intended to be used outdoors or in a wet location when it is powered by the Power over Ethernet (POE) interface, or by the external power supply. The product should only be used in these types of environments when operating on its own internal battery.



WARNING – When this product is connected to a Power over Ethernet connection, the source of the Ethernet power must meet IEEE 802.11af, and its DC output (Ethernet power source) must be completely isolated from earth ground (floating), or a shock hazard may exist.

Setting up the Receiver

In this chapter:

- Rover operation guidelines
- Setting up the SPSx61 GPS receivers to provide heading

This chapter provides guidelines for setting up the receiver as a rover receiver in a range of common use scenarios.

This chapter also describes the procedure for setting up a pair of receivers for heading and moving base marine construction applications.

Note – This chapter provides setup information for all the receivers in the SPSx61 receiver family.

Rover operation guidelines

The second part of a GPS system is the rover receiver. The rover is capable of receiving correction streams from different sources and by different methods to improve the precision of the position calculation.

The rover receiver is mounted on a vehicle, marine vessel, or construction machinery, and provides position and heading information for the operator. The rover receiver may be connected to a base station or to some other source of corrections such as a virtual reference station system, SBAS (WAAS/EGNOS/MSAS), Beacon, or an OmniSTAR service. The connection can be provided by:

- an integrated radio (UHF or MSK Beacon)
- an external cellular phone that is connected to the receiver either by Bluetooth wireless technology or by means of a cable
- through satellite reception (SBAS or OmniSTAR)

Rover receiver components

The rover receiver has the following components:

- GPS receiver
- Two GPS antennas (L1/L2/Beacon/SBAS/OmniSTAR)
- Optional integrated UHF radio receiver for RTK operations
- Optional MSK Beacon receiver for DGPS operation

Rover receiver setup guidelines

For good rover operation, observe the following setup guidelines:

- Place the GPS antennas in locations that have a clear line of sight to the sky in all directions. Do not place the antenna near vertical obstructions.
- Place the two GPS antennas at least 2 meters (6.5 feet) apart and at approximately the same height.
- Place the GPS and radio antennas as high as possible to minimize multipath from the surrounding area. The receiver must have a clear line of sight to the sky at all times during operation.



CAUTION – The GPS antenna and its cabling should be installed in accordance with all national and local electrical codes, regulations, and practices.

The antenna and cabling should be installed where they will not become energized as a result of falling nearby power lines, nor be mounted where they are subjected to overvoltage transients, particularly lightning. Such installations require additional protective means that are detailed in national and local electrical codes.

- The SPS461 can optionally track the GPS L2C modernization signal. The signal helps you to get positions at the worst times of the day and in the worst GPS locations, but does not guarantee that you will.
- Loss of the satellite signals or loss of the radio link will result in a loss of position accuracy. The Position mode will reflect this change and depending on the correction inputs available will show one of the following modes:
 - RTK Fixed – The rover has been upgraded to Precision RTK and has initialized using a valid RTK correction stream.
 - Location RTK – The rover has been upgraded to Location RTK and has initialized using a valid RTK correction stream.
 - OmniSTAR HP/XP – The rover has been upgraded to Location RTK, has a valid OmniSTAR subscription, has locked onto an OmniSTAR satellite beam, and is decoding the XP or HP correction service.
 - OmniSTAR VBS – The rover has a valid OmniSTAR subscription, has locked onto an OmniSTAR satellite beam, and is decoding the VBS correction service.
 - Beacon DGPS – The rover is locked onto a Beacon reference station and is receiving valid DGPS RTCM correction messages (Type 1 or Type 9)
 - DGPS – The rover is decoding DGPS RTCM corrections from an external source.
 - SBAS – The rover is decoding corrections from an SBAS source.
 - Autonomous – The rover has no source of corrections and is working by itself with the available GPS signals.
- On a vehicle or marine vessel, place the GPS antenna in a location as free from shock and vibration as possible. Use either a magnetic mount or a 5/8" thread bolt in a suitable location.
- Do not locate the receiver or antenna within 400 meters (about 1,300 ft) of powerful radar, television, cellular communications tower, or other transmitters or GPS antennas. Low-power transmitters, such as those in cellular phones and two-way radios, normally do not interfere with receiver operations. Cellular communication towers can interfere with the radio and can interfere with GPS signals entering the receiver. This does not harm the receiver, but it can prevent the receiver electronics from functioning correctly.
- Do not use the rover receiver directly beneath or close to overhead power lines or electrical generation facilities. The electromagnetic fields associated with these utilities can interfere with GPS receiver operation. Other sources of electromagnetic interference include:
 - gasoline engines (spark plugs)
 - televisions and computer monitors
 - alternators and generators

- electric motors
- equipment with DC-to-AC converters
- fluorescent lights
- switching power supplies
- Trimble recommends that, wherever possible, all GPS receiver equipment is protected from rain or water. Although, the receivers are designed to withstand all wet weather conditions, keeping the receivers dry prolongs the life of the equipment and reduces the effects of corrosion on ports and connectors. If the equipment gets wet, use a clean dry cloth to dry the equipment and then leave the equipment open to the air to dry. Do not lock wet equipment in a transport case for prolonged periods. Wherever possible, avoid exposing the GPS receiver to corrosive liquids and salt water.
- If you are using the rover receiver in open spaces, Trimble recommends that you stop work during electrical storms where the risk of lightning strike is high.
- Where cables are involved, Trimble recommends that you use cable ties to secure the cables to the rod or other equipment to avoid inadvertent snagging while moving about the jobsite. Be careful not to kink, twist, or unnecessarily extend cables, and avoid trapping them in vehicle doors or windows. Damage to cables can reduce the performance of GPS equipment.

Internal radio setup for rover operations

The internal receive only radio of the receiver is delivered with no radio frequencies preprogrammed into the receiver. To add receive (Rx) radio frequencies to 450 MHz radios, use the WinFlash utility or web interface (see [Appendix C, Adding UHF Internal Radio Frequencies](#)). Network channels can be selected for the 900 MHz radios.

Once the radio frequencies are configured, use the controller or receiver to select channel frequencies during rover setup operations.

Setting up the SPSx61 GPS receivers to provide heading

The SPSx61 receiver is always configured to provide precise GPS Heading when both GPS antennas are connected and have a clear view of the sky.

Even if the receiver is not connected to a correction stream and the position mode is Autonomous it will still provide the same high precision GPS Heading.

The Heading output of the SPSx61 is relative to True North.

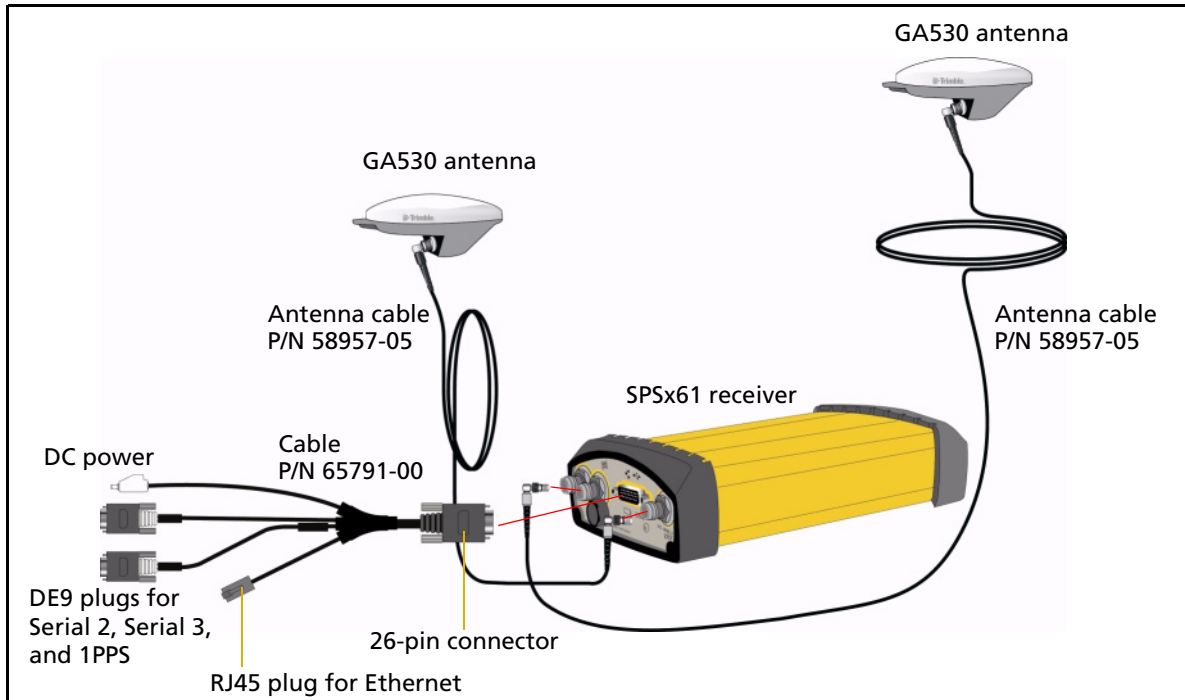

Figure 4.1 Installation setup for the SPSx61 for position and heading

Installing the receiver

Select a location at which all of the following conditions are met:

- the receiver is not exposed to temperature extremes
- the receiver is not exposed to moisture extremes (such as rain, snow, water blasters, or wash systems)
- the receiver is protected from mechanical damage
- you can connect and disconnect cables without placing undue stress on them

Mounting the antennas

You *must* install each antenna at the correct location. Poor or incorrect placement can influence accuracy and reliability.

Ideally, mount the two antennas as far apart as possible and at about the same height on the structure. Mount the antennas fore and aft along the vessel centerline or on a line that is at a known orientation to the centerline. For best results, rotate each antenna so that all antennas in the array point in the same direction. Always mount an antenna at a location that ensures a good view of the sky.

Follow these guidelines to select the antenna location:

- Choose an area with a clear view of the sky. The antenna must be above any metallic objects.
- Do not mount the antenna close to stays, electrical cables, metal masts, or other antennas.
- Do not mount the antenna near a transmitting antenna, a radar array, or near satellite communication equipment.
- Avoid areas with high vibration, excessive heat, electrical interference, and strong magnetic fields.

Use a 5/8"×11" stainless steel bolt to mount each of the antennas. There is a threaded bolt hole in the base of the antenna.



CAUTION – The GPS antenna and its cabling should be installed in accordance with all national and local electrical codes, regulations, and practices.

The antenna and cabling should be installed where they will not become energized as a result of falling nearby power lines, nor be mounted where they are subjected to overvoltage transients, particularly lightning. Such installations require additional protective means that are detailed in national and local electrical codes.

Interfacing using the NMEA protocol

The default factory settings enable the NMEA HDT and GGA output on Serial 3 of the SPSx61 receiver. An alternative configuration can be configured from the front panel of the receiver by pressing  until the NMEA screen appears and then selecting the required NMEA output message for either Serial 2 (Modem) or Serial 3.

Heading output

The heading output from an SPSx61 receiver that is in Rover or Moving Base mode is the True North Azimuth from the Vector antenna to the Position antenna. Heading output information is available in the following places:

- Receiver display
- Data outputs:
 - GSOF Attitude (see [Attitude, page 98](#))
 - NMEA HDT (see [HDT, page 74](#))
 - NMEA AVR (see [PTNL,AVR, page 75](#))

Configuring the Receiver Using the Keypad and Display







In this chapter:

- Button functions
- Power button operations
- Home screen
- Status screens
- Configuring the receiver as a rover receiver
- Configuring system settings
- Managing application files



The receiver features a keypad and display (see [Keypad and display, page 14](#)) so that you can configure the receiver without using a controller or computer.

Button functions

Use the buttons on the front panel to turn the receiver on and off and to check or change the receiver settings.

Button	Name	Function
	Power	Turns the receiver on and off. See the next section.
	Escape	Returns to the previous screen or cancels changes being made on a screen.
	Enter	Advances to the next screen or accepts changes made on a screen.
	Up	Moves the cursor between multiple fields on a screen or makes changes to an editable field.
	Down	Moves the cursor between multiple fields on a screen or makes changes to an editable field.
	Left	Moves the cursor between characters in a field that can be changed.
	Right	Moves the cursor between characters in a field that can be changed. Press this button to enter Edit mode.

Power button operations

Press the Power button  to turn the receiver on and off. In addition, you can tap  to return to the Home screen, or hold down  to perform the following operations:

To ...	Hold the  button for ...	Notes
turn off the receiver	two seconds	The display shows a countdown timer. When the display goes blank, release the Power button.
clear the almanac, ephemeris, and SV information	15 seconds	The display show a countdown timer. When the display goes blank, continue to hold the Power button. The display shows a countdown time to clear the almanac and ephemeris. When the counter reaches 0, release the Power button.
reset the receiver to its factory defaults and the default application file	35 seconds	The display show a countdown timer. When the display goes blank, continue to hold the Power button. The display show a countdown to clear the almanac and ephemeris. When the counter reaches 0, continue to hold the Power button. The display indicates a countdown to resetting the receiver. When the counter reaches 0, release the Power button.
force the receiver to power down	at least 60 seconds	If the reset method above does not work, use this method to force the receiver to turn off. When the Power LED goes off, release the Power button.

Home screen

The Home screen is the main screen displayed on the receiver. If the receiver is displaying a configuration screen and is left idle for 60 seconds, you are returned to the Home screen. It shows the following information:

- Number of satellites being tracked:
 - When the receiver is in Rover or Moving Base mode, the Home screen displays the number of satellites used to calculate the position:

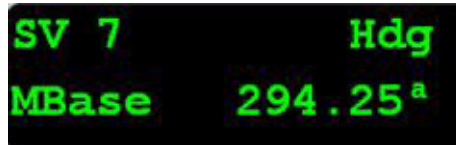

SV 7 Hdg
MBase 294.25^a

- If the receiver is set to use SBAS or OmniSTAR corrections, the Home screen displays the number of satellites that corrections have been received for.
- If the receiver is computing an autonomous solution, the Home screen displays all satellites in view, that is, all satellites above the elevation mask.



Tip – You can also view these details using the Web browser (select *Receiver Status / Position*).

- Current mode configuration:
 - Rover mode (SPS361)
 - Moving Base or Rover mode (SPS461)

- Internal radio activity

If the receiver has an internal radio, the Home screen displays the frequency or channel being used and the transmit/receive status.

- Beacon status and frequency

If the receiver is using MSK Beacon corrections, the Home screen displays the status of the signal and the frequency of the beacon station:

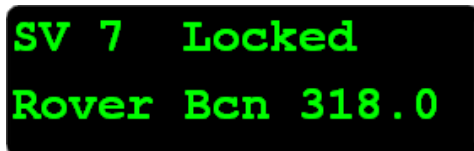

SV 7 Locked
Rover Bcn 318.0

- Current Heading
 - If the receiver is not using an internal radio or MSK Beacon radio for corrections, the Home screen displays the current heading:

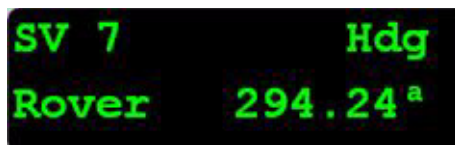

SV 7 Hdg
Rover 294.24^a

- If the receiver is using an internal radio, the Heading information can be viewed on the fifth status screen:

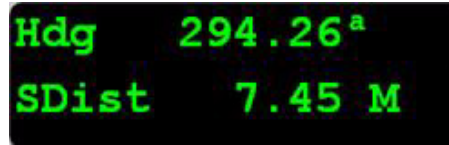

Status screens

The receiver has several view-only status screens that allow you to review the current settings of the receiver. The status screens provide the following information:

- Position solution and precisions
- CMR and RTCM IDs or OmniSTAR satellite and link status
- Base name and code or OmniSTAR mode and subscription
- Heading and Slope distance
- Latitude, longitude, and height
- Antenna height
- Receiver model and hardware version
- Receiver firmware version
- Receiver serial number
- Receiver IP address

To access these screens from the Home screen, press  or .

Radio status

When a radio is installed (either 450 MHz or 900 MHz), the following status messages are displayed in the middle of the top line of the Home screen:







Message	Description
Recv	Received a frame
Busy	Frame was blocked
Sync	Got sync with base station
Rept	Repeated a frame
Sig	Got carrier detect
Ovld	Radio bandwidth exceeded (data has probably been lost)

Configuring the receiver as a rover receiver



You can use a web browser, the HYDROpro software, or the receiver keypad to set up the SPSx61 as a rover receiver.

Configuring the receiver using the keypad



The receiver is configured step-by-step to ensure that all appropriate settings are configured. To move between steps in the configuration process, press .

1. In the Home screen, press . Use the *Operation Mode* screen to:
 - set the receiver mode (default)
 - configure system settings
 - configure the Ethernet settings
 - configure the OmniSTAR settings
 - view the SV (satellite) status
2. Press . Use the *Mode* screen to select whether the receiver will operate as a Moving Base or Rover.
3. Press . When the mode begins to flash, the receiver is in Edit mode and you can change this setting.
4. Press  to change to Rover.
5. Press  to accept the change.
6. Press  again to move to the *Beacon mode* screen. See next.

Changing the Beacon mode

1. Press . When the value for the current Beacon mode begins to flash, the receiver is in Edit mode and you can change the setting.
2. Press  to change the Beacon mode to Auto Power, Auto Range, or Manual.
3. Press  to accept the change and move to the *Elevation Mask* screen. See next.

Changing the elevation mask



1. Press . When the value for the current elevation mask begins to flash, the receiver is in Edit mode and you can change the setting.
2. Press  to change the elevation mask to the required value.

Note – Trimble recommends that you do not set the elevation mask to a value lower than 10 degrees.

3. Press  to accept the change and move to the *Position Antenna Type* screen. See next.



Selecting the Position antenna

In the *Position Antenna Type* screen:

1. Press . When the antenna name begins to flash, the receiver is in Edit mode and you can select the type of antenna that is to be attached to RF post 1 on the receiver.
2. Press  to scroll through the antenna models.
3. Once the correct antenna name appears, press  to accept the change and move to the Vector Antenna Type screen. See next.

Selecting the Vector antenna



In the *Vector Antenna Type* screen:

1. Press . When the antenna name begins to flash, the receiver is in Edit mode and you can select the type of antenna that is to be attached to RF port 2 on the receiver.
2. Press  to scroll through the antenna models.
3. Once the correct antenna name appears, press  to accept the change and move to the *RTCM Output Port* screen. See next.

Selecting the output message types and port





In the Port screen, set up the RTCM outputs from the receiver:

Note – An SPSx61 receiver can repeat the RTCM input from an internal MSK Beacon radio or OmniSTAR VBS service so it can be used by another rover.

1. Press  to accept the default of no RTCM output.
2. Use the NMEA screen to set up NMEA outputs from the receiver: Press  to accept the default NMEA output, HDT and GGA on Serial 3 at 1 Hz.
3. Use the GSOF screen to set up GSOF outputs from the receiver: Press  to accept the default of no GSOF output and move to the *Heading Adjustment* screen. See next.





Adding a Heading adjustment

In the *Heading Adj* screen, enter an adjustment value to be added to the calculated True Heading:

1. Press . When the value for the current Heading Adjustment begins to flash, the receiver is in Edit mode and you can change the setting.
2. Press  to change the Heading Adjustment to the required value.
3. Press  to accept the change.
4. Press  to move to the *Minimum Heading Solution* screen. See next.

Selecting the Minimum Heading Solution

In the *Min Hdg Soln* screen, select the minimum RTK solution which will result in a valid heading output:







1. Press . When the value for the current Minimum Heading Solution begins to flash, the receiver is in Edit mode and you can change the setting.
2. Press  to select either RTK Fixed or RTK Float from the list.
3. Press  to accept the change,
4. Press  to return to the *Home* screen.

Configuring Ethernet settings



You can use the keypad and display of the receiver to configure the following settings:

- DHCP
- IP Address
- Subnet Mask
- Gateway

To access the Ethernet settings:

1. In the Home screen, press .
2. Press . When the operation mode begins to flash, the receiver is in Edit mode and you can change this setting.
3. Press  to change to Ethernet configuration.
4. Press  to accept the change.
5. Use the *DHCP* screen to enable or disable DHCP. Press  to accept the change.
6. Use the *IP Address* screen to enter a static IP address for the SPSx61. Press  to accept the change.

Note – When using a static IP address, Trimble recommends that you disable the DHCP otherwise the DHCP server will reassign the IP address when the SPSx61 is restarted.

7. Use the *Subnet Mask* screen to enter the subnet mask required for the network. Press  to accept the change.
8. Use the *Gateway* screen to enter the gateway IP address of your network. Press  to accept the change and return to the *Home* screen.



















Configuring system settings

You can use the keypad and display of the receiver to configure the following settings:





- Display language
- Display and input units



- Set position precisions
- Baud rate, parity, data bits, and stop bits for serial ports
- Display power saver
- Activate an Appfile (stored configuration)
- Enable Power over Ethernet (PoE)

To access the system settings:

1. In the Home screen, press . Use the *Operation Mode* screen to configure system settings or mode settings, and to view the SV (satellite) status. Mode Settings is the default setting.
2. Press . When the operation mode begins to flash, the receiver is in Edit mode and you can change this setting.
3. Press  to change to System Setup.
4. Press  to accept the change.
5. Press  again.
6. Use the *Display Language* screen, if necessary, to change the language. Choose English, Dutch, Finnish, French, German, Italian, Norwegian, Polish, Spanish, or Swedish. Press  to accept the change.
7. Press  again. Use the *Display and Input Units* screen, if necessary, to change the units to Meters or US Feet.
8. Press  to accept the change. Press  again. Use the *Precision Setup* screen to set the horizontal and vertical precision values required. Press  to accept the change and then press  again to move to the next screen.
9. Press  again. Use the *Port Settings* screen, if necessary, to change the port.
10. Press  to accept the change.
11. Press  again. Use the *Screen Pwr Savr* screen to choose On, Off, or Auto. If you use the Auto setting, the screen turns off after 60 seconds of inactivity. The Power LED remains lit so that you can tell if the receiver is on or off. If an error message appears, the screen comes back on. Press  to accept the change and then press  again to move to the next screen.
12. Press  to accept the change.
13. Press  again. The *Active Appfile* screen appears.

To change the application file:

- Press  to display START Appfile.
 - Press  to show SAVE Appfile.
 - Press  to show DELETE Appfile.
 - Press  to show START Appfile.
14. Press  to accept the change.

15. Press  again. Use the *Power over Ethernet* screen to choose Enable or Disable. If connected to an 802.3af capable powered network and if PoE is enabled, the SPSx61 receiver will be powered through the RJ45 Ethernet cable.
16. Press  to accept the change and return to the *Home* screen.

Managing application files

You can use the front panel to manage application files in the receiver. You can see which application file the receiver is currently using and then choose to make changes to it and save it, load a different application file, or delete an application file.

To manage the application files, use the *System Setup* menu.

To save an application file, configure all the settings you need through the front panel and then save the file. When you save the file, the receiver provides a default filename, which you can change, based on the currently set mode. For example:

If the receiver is set to the following mode:		The suggested application filename is:
Moving Base		MB01
Rover		ROV01

Configuring the Receiver Using the Web Browser Interface

In this chapter:

- Ethernet settings
- Configuring the receiver using a web browser
- Menus

You can configure the SPSx61 Heading receiver in a variety of ways:

- Receiver keypad and display (see [Chapter 5](#))
- WinFlash utility
- Web Browser interface (this chapter)
- HYDROpro software

Ethernet settings

The receiver has an Ethernet port so that the receiver can connect to an Ethernet network. You can use the Ethernet network to access, configure, and monitor the receiver. No serial cable connection to the receiver is necessary.

The receiver requires the following Ethernet settings:

- IP setup: Static or DHCP
- IP address
- Netmask (Submask)
- Broadcast IP address
- Gateway IP address
- DNS IP address
- HTTP port

The default setting for the HTTP port is 80. The HTTP port is not assigned by the network. HTTP port 80 is the standard port for web servers. This allows you to connect to the receiver by entering only the IP address of the receiver in a web browser. If the receiver is set up to use a port other than 80, you will need to enter the IP address followed by the port number in a web browser.

Example of connecting to the receiver using port 80: `http://169.254.1.0`

Example of connecting to the receiver using port 4000: `http://169.254.1.0:4000`

The default setting of the receiver is DHCP enabled. Using DHCP enables the receiver to automatically obtain the IP address, Netmask, Broadcast, Gateway, and DNS address from the network.

When a receiver is connected to a network using DHCP, the network assigns an IP address to the receiver. To verify the IP address, select the up button from the keypad when the Home screen is displayed. The Ethernet IP address appears. The screen shown is of a receiver that has failed to get a network assigned IP address.

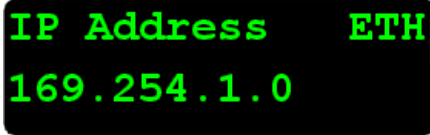

```
IP Address    ETH
169.254.1.0
```

If your network installation requires the receiver to be configured with a static IP address, you can configure the Ethernet settings using the keypad and display (see [Chapter 5](#)), web browser interface or the WinFlash utility. When DHCP fails, the receiver uses a private IP.

Configuring the receiver using a web browser

This section describes how to configure the receiver using the web browser. The web browser requires a computer running a web browser. The computer must be connected to the receiver in one of the following ways:

- Peer-to-peer using Ethernet cross-over cable or Bluetooth wireless technology
- Through a Local Area Network (LAN)
- Through the Internet

Supported browsers

- Google Chrome
- Microsoft Internet Explorer® version 6.00 or later for Windows operating systems
- Mozilla Firefox version 1.07 or later (version 1.50 or later is recommended for Windows, Macintosh, and Linux operating systems)

Connecting to the receiver using a web browser

1. Enter the IP address of your receiver (see [Ethernet settings, page 36](#)) into the address bar of the web browser as shown:



2. If security is enabled on the receiver, the web browser prompts you to enter a username and password:

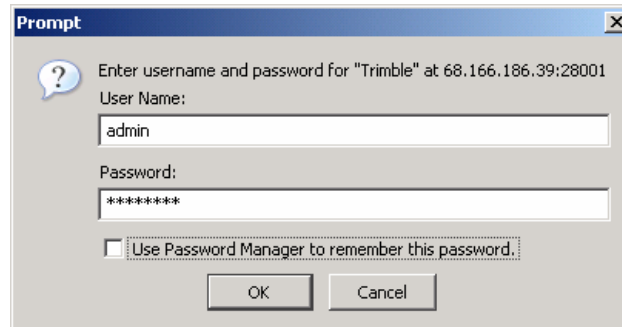

The default login values for the receiver are:

- User Name: **admin**
- Password: **password**

If you cannot connect to the receiver, the password for the admin account may have been changed, or a different account may be in use. Contact your receiver administrator for the appropriate login information.

Connecting to the receiver using a web browser and Bluetooth wireless technology

This section describes how to access the web interface on a SPSx61 Modular GPS receiver that has firmware version 3.84 or later installed, using Bluetooth wireless technology on an office computer that has Service Pack 2 of the Windows XP operating system (Professional Edition) installed.

1. On the office computer, open the Control Panel. Open Bluetooth Configuration and go to the *Client Applications* tab. The following dialog appears:

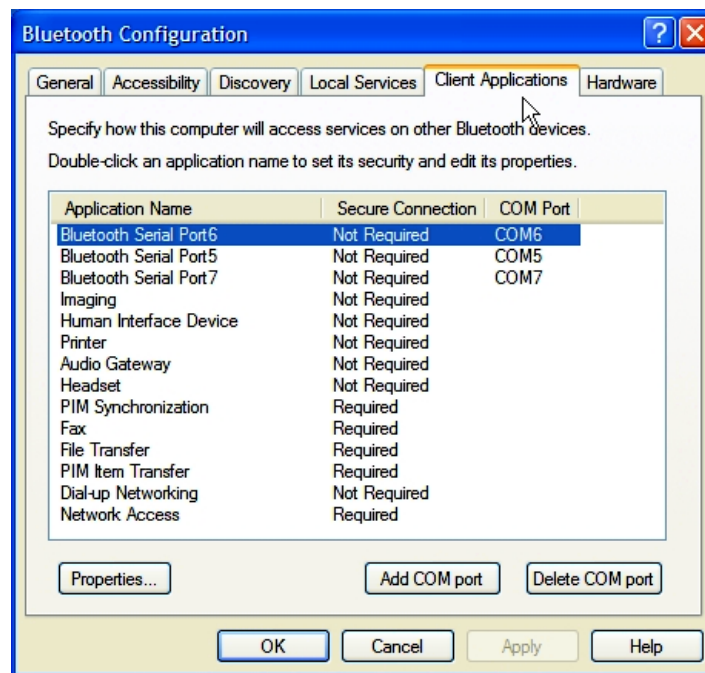

2. Add at least one Bluetooth Serial port. To do this, click **Add COM port** and then follow the steps through the wizard. Name the COM port appropriately and clear the *Secure Connection* check box.

3. Start the *Bluetooth Setup* wizard (click *Start / All Programs / My Bluetooth Places*):

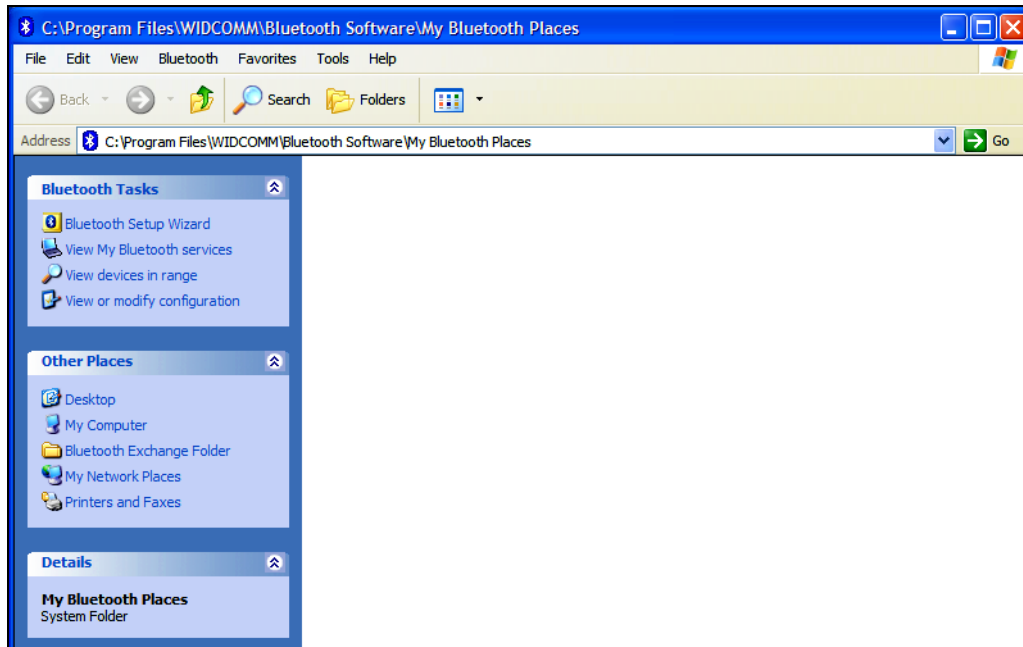

4. The *Bluetooth Setup* wizard starts. Use the settings shown below and then click **Next**:



The following dialog appears:

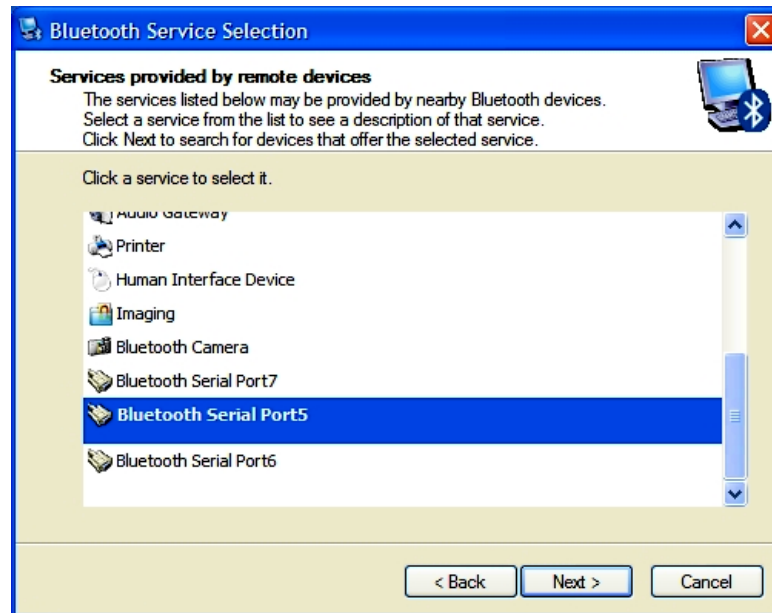

5. Select the Bluetooth serial port you created and then click **Next**. The following dialog appears:



6. In the Search criteria list, change the search to Show all devices and then select the modular GPS receiver that you want to connect to. Click **Next**.

The following dialog appears:



7. Click **Configure** to select the COM port on your office computer. Think of Bluetooth as a cable replacement and this as the serial port on your office computer into which the Bluetooth 'cable' will be connected. The following dialog appears:

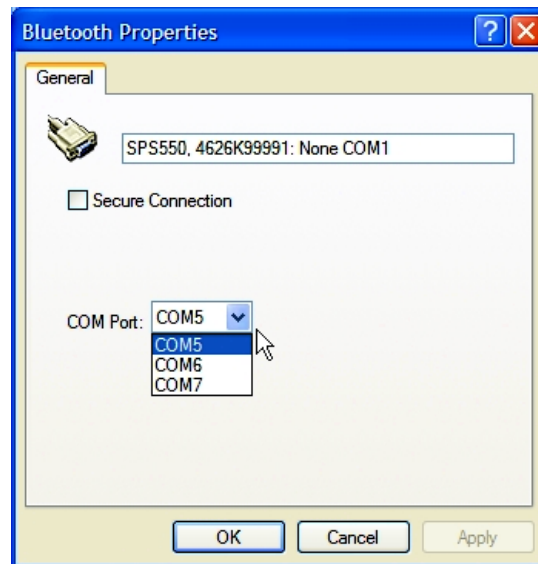

8. Ensure that the *Secure Connection* check box is cleared and then tap **OK**.
9. Tap **Finish**. The new Bluetooth connection appears in My Bluetooth places.

10. Double-click this icon to connect:

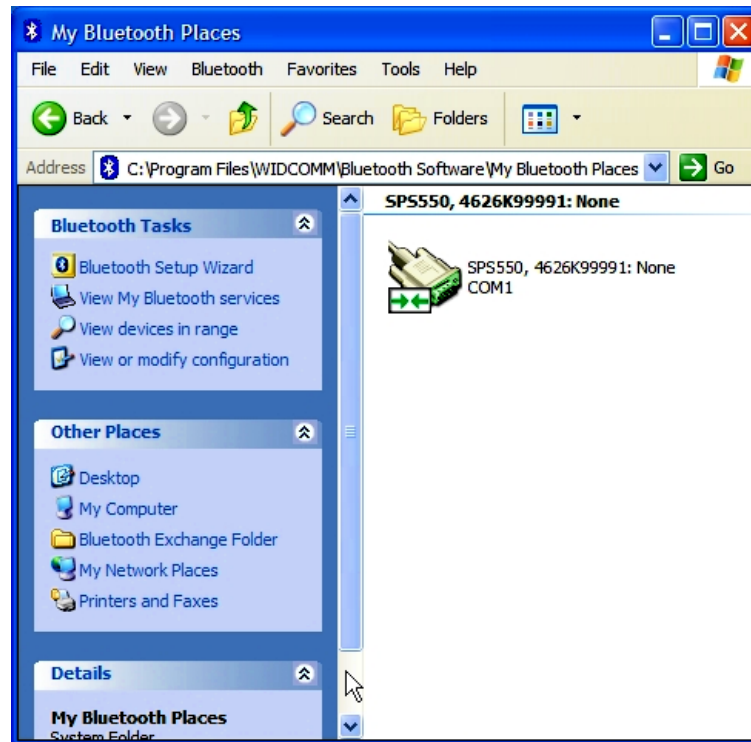

Creating a new connection

1. From your Windows Control Panel, open Network Connections and then click **Create a new connection:**

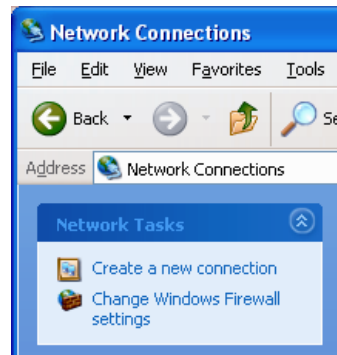

2. The *New Connection* wizard starts. Complete the wizard using the following settings:
 - Set up an advanced connection
 - Connect directly to another computer

– Guest



3. Give the connection a name which relates to the COM port being used on the office computer. This is like a cable connection between two computers only the cable is being replaced by a Bluetooth wireless connection. Tap **Next**. The following dialog appears:

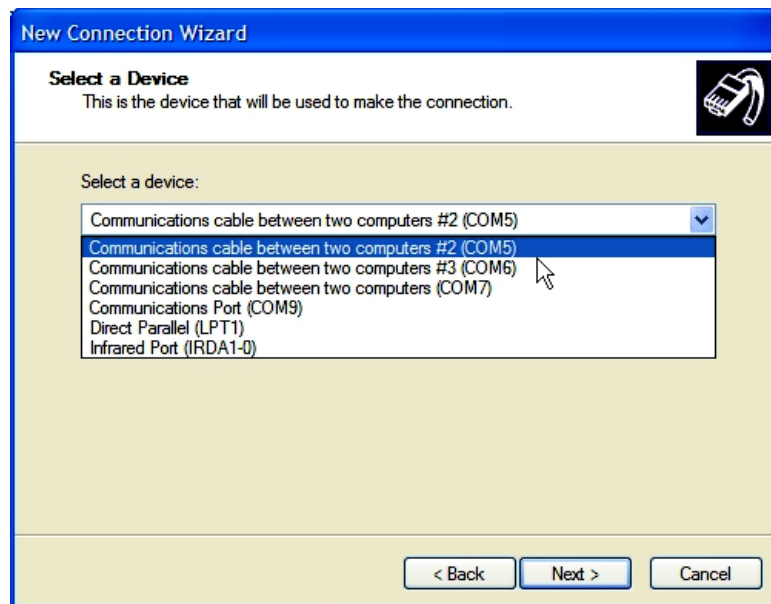

- Select the correct COM port from the list and then tap **Next**. The following dialog appears:



- Enter the user name and password and then click **Connect**.

The defaults for the SPSx61 receiver are:

Username: admin

Password: password

- The new Direct connection appears in the Network Connections folder. If that status shows as Connected, you can continue to the web interface.

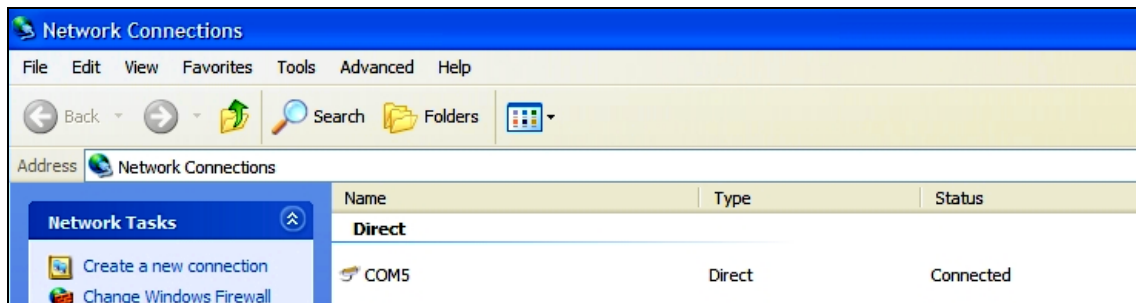

7. Right-click on the connection and select Status:

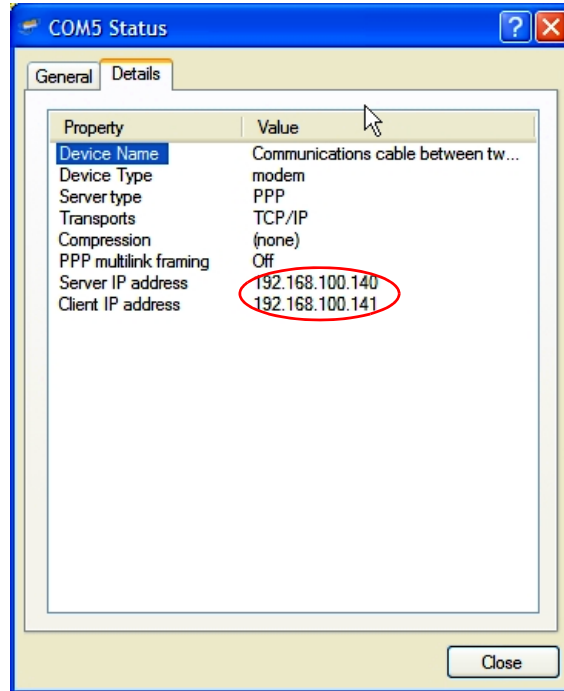

8. The *Details* tab shows the Server IP address. Use this IP to connect to the receiving using the web interface.

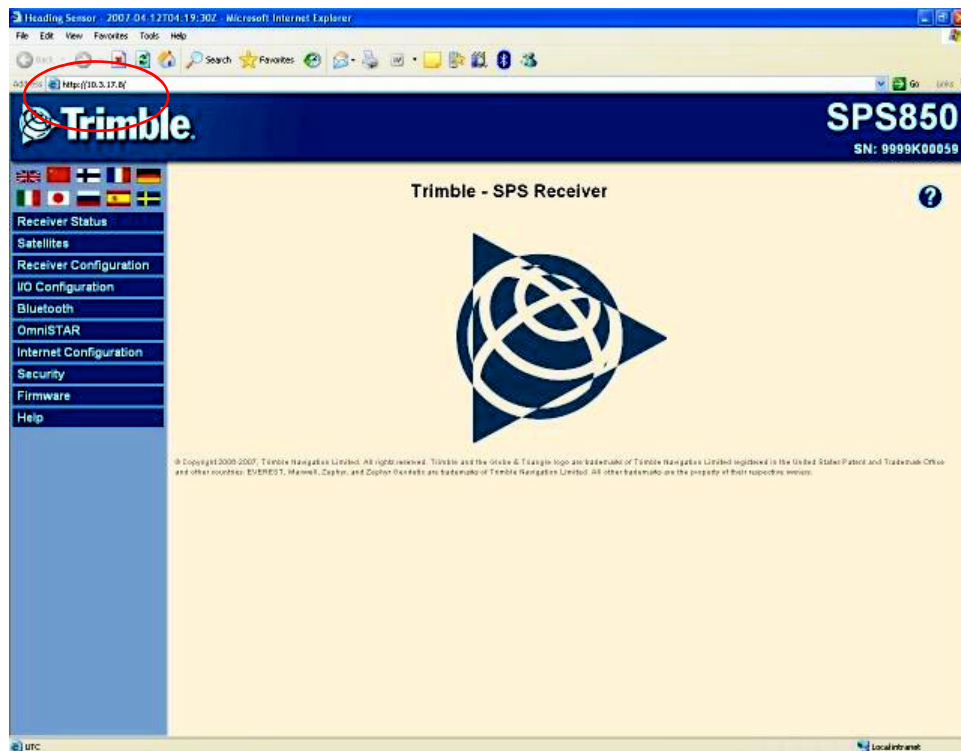

Tip – You can also get the PPP address from the front panel of the receiver by pressing  from the Home screen.

Menus

Once you are logged in, the home page appears (see [Figure 6.1](#)).



Figure 6.1 SPS GPS receiver Home page

Changing the settings

Use the webpage to configure the receiver settings. The web interface shows the configuration menus on the left of the browser window, and the settings on the right. Each configuration menu contains related submenus to configure the receiver and monitor receiver performance.

Note – The configuration menus available vary based on the version of the receiver.

A summary of each configuration menu is provided here. For more detailed information about each of the receiver settings, select the *Help* menu. The Help is available whenever your computer is connected to the Internet. It is also available anytime from the Trimble website ([link available in the Help section of the web interface](#)).

To display the web interface in another language, click the corresponding country flag. The web interface is available in the following languages:

- English (en)
- Chinese (zh)
- Dutch (nl)
- Finnish (fi)
- Japanese (ja)
- Norwegian (n)
- Polish (pl)
- Russian (ru)

- French (fr)
- German (de)
- Italian (it)
- Spanish (es)
- Swedish (sv)

Receiver Status menu

The *Receiver Status* menu provides a quick link to review the receiver's available options, current firmware version, IP address, temperature, runtime, satellites tracked, current outputs, available memory, position information, and more.

This figure shows an example of the screen that appears when you select *Receiver Status / Identity*.

Trimble **SPS461**
SN: 4840K58796

Receiver Status - Identity

System Name:	Trimble
Serial Number:	4840K58796
Ethernet MAC Address:	00:60:35:0A:45:63
Ethernet IP:	10.3.19.88
DNS Resolved Name:	NONE
Bluetooth MAC Address:	00:80:37:2f:16:e1
Firmware Version:	0.52
Firmware Date:	2008-11-21
Monitor Version:	3.60
Hardware Version:	0.0

© Copyright 2005-2008, Trimble Navigation Limited. All rights reserved. Trimble and the Globe & Triangle logo are trademarks of Trimble Navigation Limited registered in the United States Patent and Trademark Office and other countries. EVEREST, Maxwell, Zephyr, and Zephyr Geodetic are trademarks of Trimble Navigation Limited. All other trademarks are the property of their respective owners.

Satellites menu

Use the *Satellites* menu to view satellite tracking details and enable/disable GPS and SBAS (WAAS/EGNOS and MSAS) satellites.

This figure shows an example of the screen that appears when you select *Satellite / Tracking (Sky Plot)*.

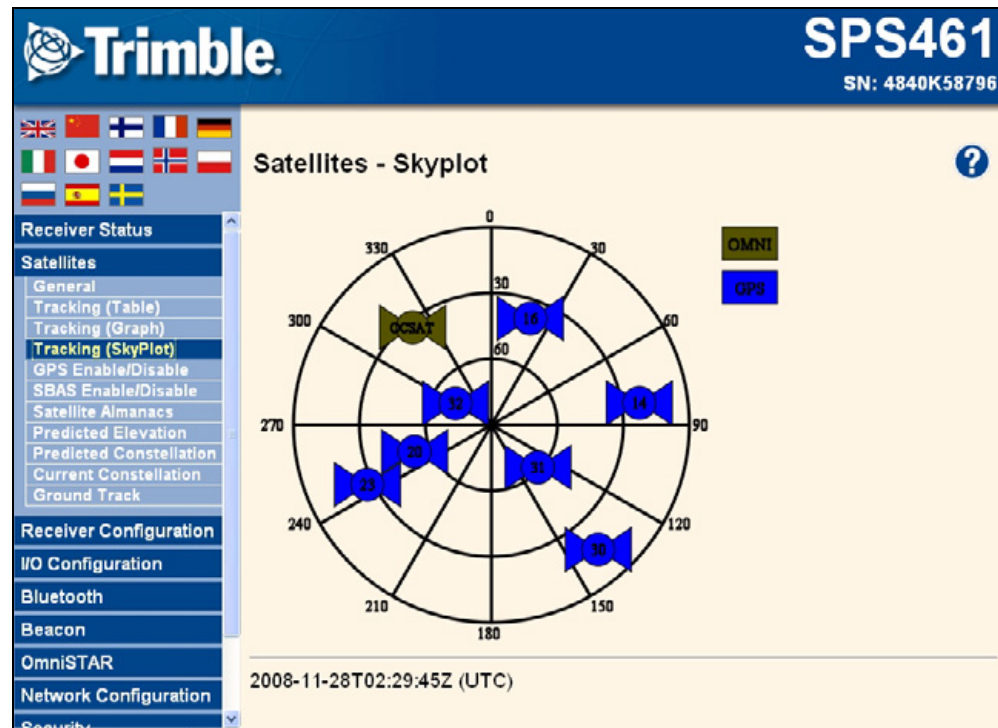

Receiver Configuration menu

Use the *Receiver Configuration* menu to configure such settings as elevation mask and PDOP mask, the antenna types and height, the heading and attitude adjustments and calibration and management of the stored configurations (Appfiles).

This figure shows an example of the screen that appears when you select *Receiver Configuration / Summary*.

Receiver Configuration	
Elevation Mask:	10°
PDOP Mask:	7
Horizontal Precision:	0.30 [m]
Vertical Precision:	0.30 [m]
Clock Steering:	Disabled
Everest™ Multipath Mitigation:	Enabled
Antenna ID:	250
Antenna Type:	GA530
Antenna Height:	0.000 [m]
1PPS On/Off:	Enabled
RTK Mode:	Low Latency
Motion:	Kinematic
CMR Input Filter:	Disabled
Reference Latitude:	43°32'41.50326"S
Reference Longitude:	172°35'29.10121"E
Reference Height:	37.330 [m]
CMR ID:	0
Station Name:	CREF0001
Ethernet IP:	10.3.19.88
System Name:	Trimble
DNS Resolved Name:	NONE
Serial Number:	4840K58796
Firmware Version:	0.52
Firmware Date:	2008-11-21

I/O Configuration menu

Use the *I/O Configuration* menu to set up all outputs of the receiver. The receiver can output CMR, RTCM, NMEA, GSOF, or BINEX messages. These messages can be output on TCP/IP, NTRIP, UDP, serial, Bluetooth, or radio ports.

This figure shows an example of the screen that appears when you select *I/O Configuration / Port Summary*.

The screenshot shows the Trimble SPS461 web interface. The top header includes the Trimble logo and the model number SPS461 with serial number SN: 4840K58796. The left sidebar contains a navigation menu with the following items: Receiver Status, Satellites, Receiver Configuration, I/O Configuration (highlighted), Port Summary, Port Configuration, Bluetooth, Beacon, OmniSTAR, Network Configuration, Security, Firmware, and Help. The main content area is titled 'I/O Configuration' and contains a table with the following data:

Type	Port	Input	Output
TCP/IP	5000	-	-
TCP/IP	5017	-	-
NTripClient	-	-	-
NTripServer	-	-	-
NTripCaster 1	8000	-	-
NTripCaster 2	8001	-	-
NTripCaster 3	8002	-	-
Serial	Modem 1 (38.4K-8N1)	-	-
Serial	Modem 2 (38.4K-8N1)	-	NMEA-GGA(1Hz) NMEA-HDT(1Hz)
Bluetooth	1	-	-
Bluetooth	2	-	-
Bluetooth	3	-	-
USB	-	-	-
Radio	-	-	-

Bluetooth menu

Use the *Bluetooth* menu to configure the receiver to connect to other devices that use Bluetooth wireless technology. These devices can be used to configure the receiver, and generate or receive corrections. The following Trimble devices can be connected to an SPSx61 receiver using Bluetooth wireless technology:

- Laptop computer
- SNB900 radio-modem
- Other Bluetooth-enabled SPS GPS receivers

This figure shows an example of the screen that appears when you select *Bluetooth / Info*.

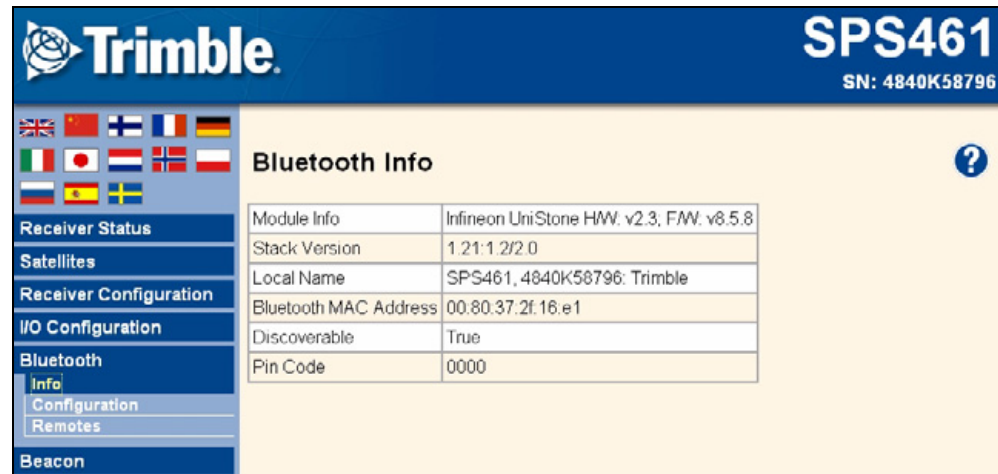

The screenshot shows the Trimble SPS461 web interface. The top header includes the Trimble logo and the device model 'SPS461' with serial number 'SN: 4840K58796'. A navigation menu on the left lists various configuration options, with 'Bluetooth' expanded to show 'Info', 'Configuration', and 'Remotes'. The main content area is titled 'Bluetooth Info' and contains a table with the following data:

Module Info	Infinion UniStone HW: v2.3, FW: v8.5.8
Stack Version	1.21:1.2/2.0
Local Name	SPS461, 4840K58796: Trimble
Bluetooth MAC Address	00:80:37:2f:16:e1
Discoverable	True
Pin Code	0000

Beacon menu

Use the *Beacon* menu to configure the internal dual-channel MSK Beacon receiver. When enabled and locked to a Beacon signal in the 283.5 KHz to 325.0 KHz range, the receiver will decode DGPS RTCM messages and provide a sub-meter position solution.

This figure shows an example of the screen that appears when you select Beacon.



The screenshot shows the Trimble SPS461 web interface. The top header includes the Trimble logo and the device model 'SPS461' with serial number 'SN: 4840K58796'. A left sidebar contains a menu with options: Receiver Status, Satellites, Receiver Configuration, I/O Configuration, Bluetooth, Beacon (selected), Configuration, Status, Beacon Locations, OmniSTAR, Network Configuration, Security, Firmware, and Help. The main content area is titled 'Beacon Information' and contains the following data:

Tune Mode Configuration:	
Tune Mode:	Manual
Primary Channel Status:	
Frequency [KHz]:	318.0
Status:	Searching
Age of Correction[sec]:	49.2
Time since last correction[sec]:	49.5
SNR [dB]:	4
Input Level [dB uV/m]:	2
Station ID:	713
Station Name:	Mallacoota Vic
Distance to Reference Station [m]:	1953860
MSK rate [bps]:	200
Word Error Rate [%]:	100
RTCM message throughput [%]:	0
AGC gain in dB [0-48]:	48

At the bottom of the main content area, the timestamp '2008-11-28T02:57:51Z (UTC)' is displayed.

Radio menu

Use the *Radio* menu to configure the internal radio of the receiver, if applicable. The receivers are available with 410–470 MHz or 900 MHz radios. The SPS361 receiver **does not** have an internal radio.

This figure shows an example of the screen that appears when you select *Radio*.

The screenshot shows the Trimble SPS461 web interface. The top header includes the Trimble logo and the model number SPS461 with serial number SN: 4845K59303. A left sidebar contains a navigation menu with options: Receiver Status, Satellites, Data Logging, Receiver Configuration, I/O Configuration, Bluetooth, Beacon, Radio (selected), Configuration, Frequency Management, OmniSTAR, and Network Configuration. The main content area is titled 'Radio Configuration' and includes a help icon. It displays the following information:

- Hardware type: Internal 450 MHz receiver
- Hardware ID: 80
- Hardware Version: 1
- Firmware version: 3.0.0 30Oct2008
- Radio state: OK
- Radio mode: Receive (dropdown menu)
- Radio country code: Rest of World

Below this is the '450 MHz Radio Parameters' section:

- Frequency range (MHz): 410.000 - 470.000
- Channel spacing (kHz): 25.0
- Current channel (MHz): 462.12500 (dropdown menu)
- Wireless mode: TT450s 9600 bps (dropdown menu)

An 'OK' button is located at the bottom left of the configuration area.

OmniSTAR menu

All receivers can receive OmniSTAR corrections. By default, OmniSTAR tracking is turned off in the receiver. To receive OmniSTAR corrections, you must enable the receiver to track OmniSTAR satellites and it must have a valid OmniSTAR subscription. To purchase a subscription for your receiver, contact OmniSTAR at:

www.OmniSTAR.com

North & South America, 1-888-883-8476 or 1-713-785-5850

Europe & Northern Africa, 31-70-317-0900

Australia & Asia, 61-8-9322 5295

Southern Africa, 27 21 552 0535

This figure shows an example of the screen that appears when you select *OmniSTAR / Summary*.

The screenshot displays the Trimble SPS461 web interface. The header shows the Trimble logo and the device model 'SPS461' with serial number 'SN: 4840K58796'. A navigation menu on the left lists various settings categories, with 'OmniSTAR Summary' selected. The main content area displays the 'OmniSTAR Summary' table.

OmniSTAR Summary	
Signal Source	Demodulator
SV name	Auto/PORH_
Frequency [MHz]	1535.0225
Bit Rate [Hz]	1200
Setting	VBS only
Mode	Tracking
SNR (Eb/No)	7.57
Total messages	24
Bad messages	0
Total unique word bits	1600
Bad unique word bits	2
Total Viterbi symbols	203200
Corrected Viterbi symbols	292

Network Configuration menu

Use the *Network Configuration* menu to configure Ethernet settings, email alerts, PPP connection, HTTP port, FTP port, Dynamic DNS, and VFD port settings of the receiver. For information on the Ethernet settings, see [Ethernet settings, page 36](#).

The VFD port allows you to use the SPSx61 Remote Control application to view and navigate the receiver through a mock display and keypad interface. To allow the SPSx61 Remote Control to connect to the receiver, you need to enable the VFD port. To do this, select *Network Configuration / VFD*.

This figure shows an example of the screen that appears when you select *Network Configuration / Ethernet*.

The screenshot shows the Trimble SPS461 web interface. The top header includes the Trimble logo and the device model 'SPS461' with serial number 'SN: 4840K58796'. A navigation menu on the left lists various configuration options, with 'Network Configuration' expanded to show 'Ethernet' selected. The main content area is titled 'Ethernet Configuration' and contains two sections: 'Stored settings' and 'Current settings'. The 'Stored settings' section shows a dropdown menu set to 'DHCP' and input fields for IP Address (10.3.19.88), Netmask (255.255.252.0), Broadcast (10.3.19.255), Gateway (10.3.16.1), Force DNS Address (unchecked), DNS Address (10.3.0.124), DNS Domain (ap.trimblecorp.net), Hostname (trim4840K58796), and MTU (1500). An 'OK' button is located below these fields. The 'Current settings' section displays the same information as the stored settings, but with the IP Setup set to 'DHCP' and the Force DNS Address set to '0'.

Setting	Stored settings	Current settings
IP Setup:	DHCP	DHCP
IP Address:	10 . 3 . 19 . 88	10 . 3 . 19 . 88
Netmask:	255 . 255 . 252 . 0	255 . 255 . 252 . 0
Broadcast:	10 . 3 . 19 . 255	10 . 3 . 19 . 255
Gateway:	10 . 3 . 16 . 1	10 . 3 . 16 . 1
Force DNS Address:	<input type="checkbox"/>	0
DNS Address:	10 . 3 . 0 . 124	10 . 3 . 0 . 124
DNS Domain:	ap.trimblecorp.net	ap.trimblecorp.net
Hostname:	trim4840K58796	trim4840K58796
MTU:	1500	1500
Lease Time:		4 Days 23:43:55

Security menu

Use the *Security* menu to configure the login accounts for all users who will be permitted to configure the receiver using a web browser. Each account consists of a username, password, and permissions. Administrators can use this feature to limit access to other users. Security can be disabled for a receiver. However, Trimble discourages this as it makes the receiver susceptible to unauthorized configuration changes.

This figure shows an example of the screen that appears when you select *Security / Configuration*.

Trimble **SPS461**
SN: 4840K58796

Security Configuration ?

Security:

Delete?	Username	Edit User	File Download	File Delete	Receiver Config	NTripCaster
<input type="checkbox"/>	admin	<input checked="" type="checkbox"/>	<input checked="" type="checkbox"/>	<input checked="" type="checkbox"/>	<input checked="" type="checkbox"/>	<input checked="" type="checkbox"/>

Add User?

Username:

Password:

Verify Password:

Edit User	File Download	File Delete	Receiver Config	NTripCaster
<input type="checkbox"/>	<input type="checkbox"/>	<input type="checkbox"/>	<input type="checkbox"/>	<input type="checkbox"/>

Firmware menu

Use the *Firmware* menu to verify the current firmware and load new firmware to the receiver. You can upgrade firmware across a network or from a remote location without having to connect to the receiver with a serial cable.

This figure shows an example of the screen that appears when you select *Firmware*.

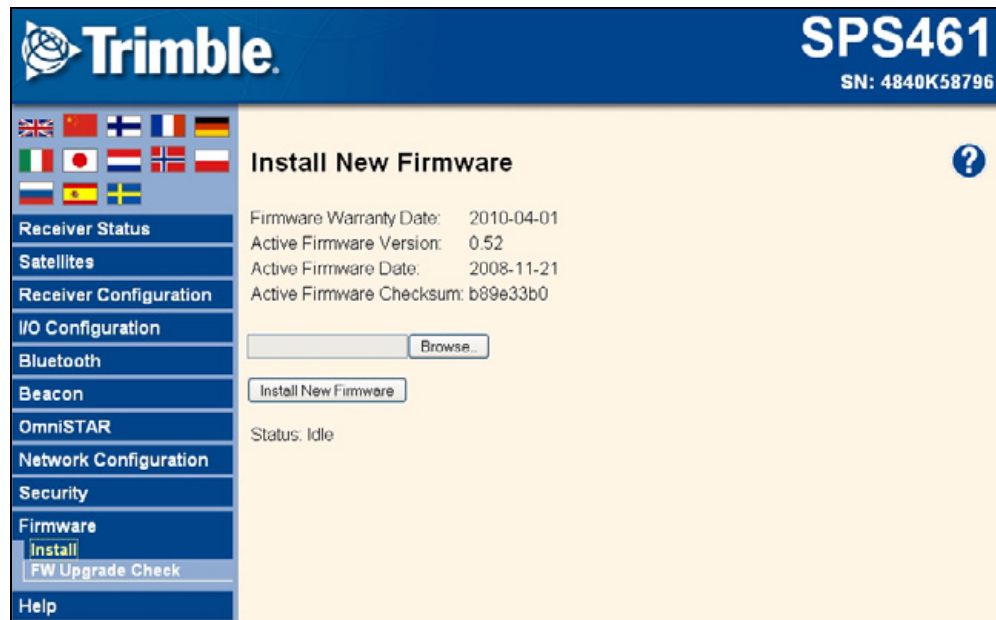

Help Menu

The *Help* menu provides information on each of the receiver settings available in a web browser. Selecting the *Help* menu opens new windows. Select the section of the Help that you want to view. The Help files are stored on the Trimble Internet site (www.trimble.com/EC_ReceiverHelp/v3.80/en) (For languages other than English, replace **en** with the appropriate two-letter country code (see [page 46](#))) and are updated between firmware releases.

To access the Help, your computer must be connected to the Internet. If you do not have access to the Internet, there is also a copy of the receiver Help files on the *Trimble SPS GPS Receiver CD*. (This copy shows the Help files as they were when the CD was published.)

This figure shows an example of the screen that appears when you select *Help*.

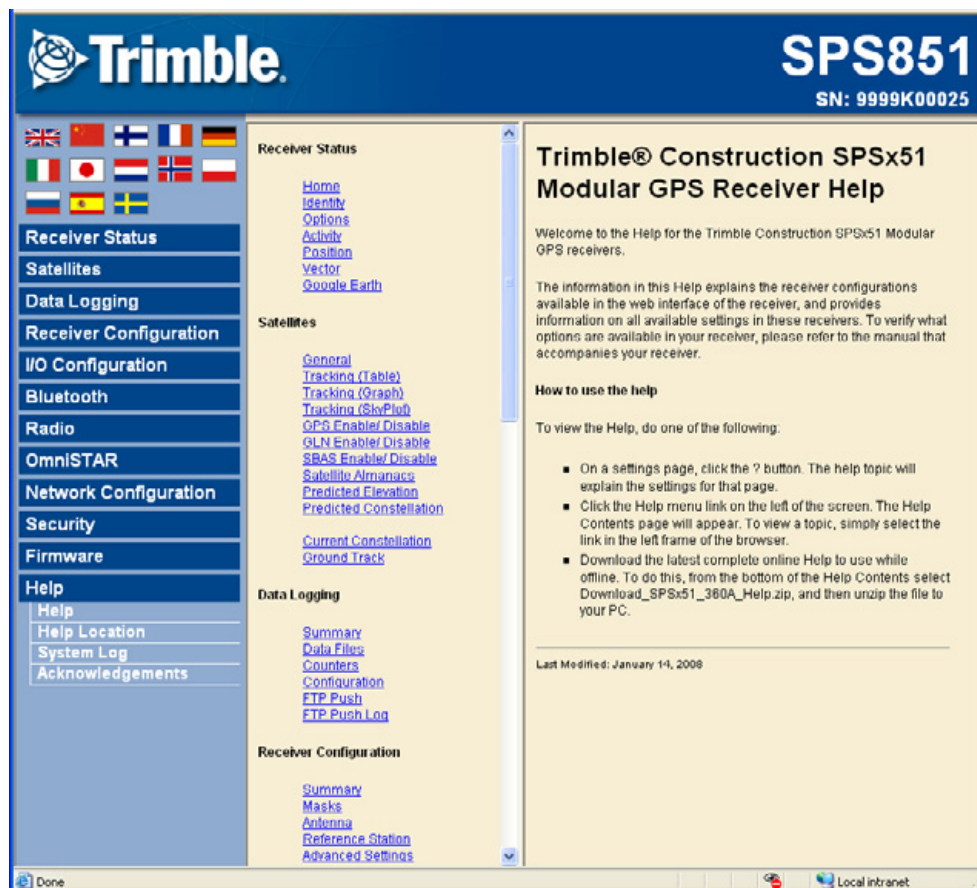

Default Settings

In this chapter:

- [Default receiver settings](#)
- [Resetting the receiver to factory defaults](#)

All settings are stored in application files (Appfiles). The default application file, Default.cfg, is stored permanently in the receiver, and contains the factory default settings. Whenever the receiver is reset to its factory defaults, the current settings (stored in the current application file, Current.cfg) are reset to the values in the default application file.

Default receiver settings

These settings are defined in the default application file.

Function		Factory default
SV Enable		All SVs enabled
General Controls:	Elevation mask	10°
	PDOP mask	7
	RTK positioning mode	Low Latency
	Motion	Kinematic
Serial 3 Port:	Baud rate	38,400
	Format	8-None-1
	Flow control	None
Serial 2 (Modem) Port:	Baud rate	38,400
	Format	8-None-1
	Flow control	None
Input Setup:	Station	Any
NMEA/ASCII (all supported messages)		GGA, HDT @ 1 Hz on Serial 3 port
Streamed output		All types Off Offset = 00
RT17/Binary		All ports Off
OmniSTAR	Internal demodulator	Off
	External OmniSTAR data	VBS only
Beacon	Tune mode	Autopower
Position and Vector antenna:	Type	GA530
	Height (true vertical)	0.00 m
	Measurement method	Antenna phase center

Resetting the receiver to factory defaults

To reset the receiver to its factory defaults, press  for 35 seconds. Alternatively, in the web interface select *Receiver Configuration / Reset*.

Specifications

In this chapter:

- Configuration options
- General specifications
- Antenna options
- Temperature
- Shock and vibration
- Measurements
- Positioning
- Initialization time
- Power
- Regulatory approvals
- Communications
- Notes
- Variable configuration options

This chapter details the specifications for the receiver.

Specifications may vary between each model. For further details, please refer to the specific datasheet.

Specifications are subject to change without notice.

Configuration options

Configuration Option	Precise RTK
Base and Rover interchangeability	No, Rover only
Rover position update rate	1 Hz, 2 Hz, 5 Hz, 10 Hz, 20Hz
Rover maximum range from base	Unrestricted. Typical range 2 – 5 km (1.2 – 3 miles) without radio repeater.
Rover operation within a VRS™ network	Yes
Factory options	

General specifications

Keyboard and display	VFD display 16 characters by 2 rows On/Off key for one button start up Escape and Enter key for menu navigation 4 arrow keys (up, down, left, right) for option scrolls and data entry
Dimensions (L x W x D)	24 cm x 12 cm x 5 cm (9.4 in x 4.7 in x 1.9 in) including connectors
Weight	1.22 kg (2.70 lb) receiver only 1.37 kg (3.00 lb) receiver with internal radio

Antenna options

GA510	L1/L2/L2C GPS, SBAS, and OmniSTAR (optimised for OmniSTAR)
GA530	L1/L2/L2C GPS, SBAS, and OmniSTAR
L1/Beacon, DSM 232	Not supported
Zephyr™ Model 2	L1/L2/L2C GPS, SBAS, and OmniSTAR
Zephyr Geodetic™ Model 2	L1/L2/L2C GPS, SBAS, and OmniSTAR
Zephyr™ Model 2 Rugged	L1/L2/L2C GPS, SBAS, and OmniSTAR
Zephyr, Zephyr Geodetic, Z-Plus, Micro-Centered™	Refer to Antenna specification

Temperature

Operating ¹	-40 °C to +65 °C (-40 °F to +149 °F)
Storage	-40 °C to +80 °C (-40 °F to +176 °F)
Humidity	MIL-STD 810F, Method 507.4
Waterproof	IP67 for submersion to depth of 1 m (3.3 ft), dustproof

Shock and vibration

Pole drop	Designed to survive a 1 m (3.3 ft) pole drop onto a hard surface
Shock – Non-operating	To 75 g, 6 ms
Shock – Operating	To 40 g, 10 ms, saw-tooth
Vibration	Tested to Trimble ATV profile (4.5 g RMS): 10 Hz to 300 Hz: 0.04 g/Hz;2 300 Hz to 1,000 Hz; –6 dB/octave

Measurements

Advanced Trimble Maxwell™ 5 Custom GPS chip
High-precision multiple correlator for L1/L2 pseudo-range measurements
Unfiltered, unsmoothed pseudo-range measurements data for low noise, low multipath error, low-time domain correlation, and high-dynamic response
Very low noise carrier phase measurements with <1 mm precision in a 1 Hz bandwidth
L1/L2 signal-to-noise ratios reported in dB-Hz
Proven Trimble low elevation tracking technology
72-channel L1 C/A code, L1/L2/L2C Full Cycle Carrier.
Trimble EVEREST™ multipath signal rejection
4-channel SBAS (WAAS/EGNOS/MSAS)

Positioning

Code Differential GPS Positioning²

Horizontal accuracy	0.25 m + 1 ppm RMS (0.8 ft + 1 ppm RMS)
Vertical accuracy	0.50 m + 1 ppm RMS (1.6 ft + 1 ppm RMS)

SBAS (WAAS/EGNOS/MSAS) Positioning³

Horizontal accuracy	Typically <1 m (3.3 ft)
Vertical accuracy	Typically <5 m (16.4 ft)

OmniSTAR Positioning

VBS service accuracy	Horizontal <1 m (3.3 ft)
XP service accuracy	Horizontal 0.2 m (0.66 ft), Vertical 0.3 m (1.0 ft)
HP service accuracy	Horizontal 0.1 m (0.33 ft), Vertical 0.15 m (0.5 ft)

Real-Time Kinematic (RTK) Positioning

Horizontal accuracy	10 mm + 1 ppm RMS (0.032 ft + 1 ppm RMS)
Vertical accuracy	20 mm + 1 ppm RMS (0.065 ft + 1 ppm RMS)

Precise Heading

Heading accuracy	
2 m antenna separation	0.09° RMS
10 m antenna separation	0.05° RMS

Initialization time

Regular RTK operation with base station	Single/Multi-base Minimum 10 seconds + 0.5 times baseline length in km, up to 30 km
RTK operation with Scalable GPS infrastructure Initialization reliability ⁴	Typically <30 seconds anywhere within coverage area >99.9%

Power

External	Power input on the 26-pin D-sub connector is optimized for Trimble Lithium-ion battery input with a cut-off threshold of 9.5 V 11 V DC to 28 V DC external power input with over-voltage protection Receiver automatically turns on when connected to external power
Power over Ethernet (PoE)	44 V DC to 57 V DC, IEEE802.3af compliant device
Power consumption	6.0 W in rover mode with internal receive radio

Regulatory approvals

FCC: Part 15 Subpart B (Class B Device) and Subpart C, Part 90 Industry Canada: ICES-003 (Class B Device), RSS-210, RSS-Gen, RSS-310, RSS-119 R&TTE Directive: EN 301 489-1/-5/-17, EN 300 440, EN 300 328, EN 300 113, EN 60950, EN 50371 ACMA: AS/NZS 4295 approval CE mark compliance C-tick mark compliance RoHS compliant WEEE compliant	
--	--

Communications

Modem 1 (Serial)	26-pin D-sub, Serial 2, Full 9-wire RS232, using adaptor cable
Modem 2 (Serial)	26-pin D-sub, Serial 3, 3-wire RS-232, using adaptor cable
1PPS (1 Pulse-per-second)	Available
Ethernet	Through a multi-port adaptor or cable 65791-00
Bluetooth wireless technology	Fully-integrated, fully-sealed 2.4 GHz Bluetooth ⁶ module
Integrated radios (optional)	Fully-integrated, fully-sealed internal MSK Beacon and 450 MHz (UHF) Rx only or Internal 900 MHz Rx only
Channel spacing (450 MHz)	12.5 kHz or 25 kHz spacing available

External GSM/GPRS, cell phone support	Supported for direct-dial and Internet-based correction streams
Internal MSK Beacon receiver	If internal MSK Beacon radio is installed Frequency range 283.5 - 325.0 kHz Channel spacing 500 Hz MSK bit rate 50, 100, and 200 bps Demodulation Minimum shift key (MSK)
Receiver position update rate	1 Hz, 2 Hz, 5 Hz, 10 Hz, and 20 Hz positioning
Correction data input	CMR™, CMR+™, CMRx™, RTCM 3, RTCM 2.x
Correction data output	Moving Base CMR
Data outputs	NMEA, GSOF, 1PPS Time Tags

Notes

- 1 Receiver will operate normally to -40°C.
- 2 Accuracy and reliability may be subject to anomalies such as multipath, obstructions, satellite geometry, and atmospheric conditions. Always follow recommended practices.
- 3 Depends on SBAS system performance.
- 4 May be affected by atmospheric conditions, signal multipath, and satellite geometry. Initialization reliability is continuously monitored to ensure highest quality.
- 6 Bluetooth type approvals are country-specific. For more information, contact your local Trimble office or representative.

Signal tracking

This table shows the signal tracking capability for each receiver in the SPSx61 Modular GPS receiver family.

GPS signal type	Class	SPS361	SPS461	SPS461 DGPS	SPS461 LocRTK	SPS461 Precise Vertical	SPS461 PrecisionRTK
GPS signals	L1	✓	✓	✓	✓	✓	✓
	L2	✗	✓	✓	✓	✓	✓
	L2C	✗	Optional	Optional	Optional	✓	✓
GPS SBAS corrections	WAAS	✓	✓	✓	✓	✓	✓
	EGNOS	✓	✓	✓	✓	✓	✓
	MSAS	✓	✓	✓	✓	✓	✓
OmniSTAR corrections	XP	✗	✓	✗	✓	✓	✓
	HP	✗	✓	✗	✓	✓	✓
	VBS	✓	✓	✓	✓	✓	✓
Beacon corrections	MSK	Optional	Optional	Optional	Optional	Optional	Optional

Variable configuration options

This table lists the default options for each receiver in the SPSx61 Modular GPS receiver family.

Configuration option	SPS361	SPS461
Rover options		
Precise horizontal	–	Optional
Precise vertical	–	Optional
Precise heading/vector	✓	✓
Location RTK	–	Optional
RTCM DGPS	✓	✓
Signal options		
L2C		Optional
SBAS	✓	✓
OmniSTAR VBS	✓	✓
OmniSTAR HP/XP		Optional
Beacon	✓	✓
General options		
VRS support	✓	✓
Max data rate	20 Hz	20 Hz

Upgrading the receiver

Only the SPS461 receiver can be upgraded. There are four levels of positioning precision available:

- SPS461 DGPS and OmniSTAR VBS (Standard)
- SPS461 Location RTK and OmniSTAR HP/XP (Upgrade)
- SPS461 Location RTK with precise vertical measurement (Upgrade)
- SPS461 Precision RTK (Upgrade)

When you purchase the receiver upgrade, your Trimble dealer will provide you with a set of codes to change the receiver configuration. See also [Appendix E, Upgrading the Receiver Firmware](#).

NMEA-0183 Output

In this appendix:

- [NMEA-0183 message overview](#)
- [Common message elements](#)
- [NMEA messages](#)

This appendix describes the formats of the subset of NMEA-0183 messages that are available for output by the receivers. For a copy of the NMEA-0183 Standard, go to the National Marine Electronics Association website at www.nmea.org.

NMEA-0183 message overview

When NMEA-0183 output is enabled, a subset of NMEA-0183 messages can be output to external instruments and equipment connected to the receiver serial ports. These NMEA-0183 messages let external devices use selected data collected or computed by the GPS receiver.

All messages conform to the NMEA-0183 version 3.01 format. All begin with \$ and end with a carriage return and a line feed. Data fields follow comma (,) delimiters and are variable in length. Null fields still follow comma (,) delimiters but contain no information.

An asterisk (*) delimiter and checksum value follow the last field of data contained in an NMEA-0183 message. The checksum is the 8-bit exclusive of all characters in the message, including the commas between fields, but not including the \$ and asterisk delimiters. The hexadecimal result is converted to two ASCII characters (0–9, A–F). The most significant character appears first.

The following table summarizes the set of NMEA messages supported by the receiver, and shows the page that contains detailed information about each message.

Message	Function	Page
GGA	Time, position, and fix related data	70
GSA	GPS DOP and active satellites	71
GST	Position error statistics	72
GSV	Number of SVs in view, PRN, elevation, azimuth, and SNR	73
HDT	Heading from True North	74
PTNL,AVR	Time, yaw, tilt, range, mode, PDOP, and number of SVs for Moving Baseline RTK	75
PTNL, BPQ	Base station position and position quality indicator	76
PTNL, DG	L-band corrections and beacon signal strength and related information	77
PTNL,GGK	Time, position, position type and DOP values	78
PTNL,PJK	Local coordinate position output	79
PTNL,VGK	Time, locator vector, type and DOP values	80
PTNL,VHD	Heading Information	81
RMC	Position, Velocity, and Time	82
ROT	Rate of turn	83
VTG	Actual track made good and speed over ground	84
ZDA	UTC day, month, and year, and local time zone offset	85

To enable or disable the output of individual NMEA messages, do one of the following:

- Create an application file in the GPS Configurator software that contains NMEA output settings and then send the file to the receiver.
- Add NMEA outputs in the *Serial outputs* tab of the GPS Configurator software and then apply the settings.

Common message elements

Each message contains:

- a message ID consisting of *\$GP* followed by the message type. For example, the message ID of the GGA message is *\$GPGGA*.
- a comma
- a number of fields, depending on the message type, separated by commas
- an asterisk
- a checksum value

Below is an example of a simple message with a message ID (*\$GPGGA*), followed by 13 fields and a checksum value:

```
$GPGGA,172814.0,3723.46587704,N,12202.26957864,W,2,6,1.2,18.893,M,-
25.669,M,2.0,0031*4F
```

Message values

NMEA messages that the receiver generates contains the following values.

Latitude and longitude

Latitude is represented as *ddmm.mmmm* and longitude is represented as *dddmm.mmmm*, where:

- *dd* or *ddd* is degrees
- *mm.mmmm* is minutes and decimal fractions of minutes

Direction

Direction (north, south, east, or west) is represented by a single character: *N*, *S*, *E*, or *W*.

Time

Time values are presented in Universal Time Coordinated (UTC) and are represented as *hhmmss.cc*, where:

- *hh* is hours, from 00 through 23
- *mm* is minutes
- *ss* is seconds
- *cc* is hundredths of seconds

NMEA messages

When NMEA-0183 output is enabled, the following messages can be generated.

GGA Time, Position, and Fix Related Data

An example of the GGA message string is shown below. [Table A.1](#) describes the message fields.

Note – The following data string exceeds the NMEA standard length.

```
$GPGGA,172814.0,3723.46587704,N,12202.26957864,W,
2,6,1.2,18.893,M,-25.669,M,2.0,0031*4F
```

Table A.1 GGA message fields

Field	Meaning
0	Message ID \$GPGGA
1	UTC of position fix
2	Latitude
3	Direction of latitude: N: North S: South
4	Longitude
5	Direction of longitude: E: East W: West
6	GPS Quality indicator: 0: Fix not valid 1: GPS fix 2: Differential GPS fix, OmniSTAR VBS 4: Real-Time Kinematic, fixed integers 5: Real-Time Kinematic, float integers, OmniSTAR XP/HP or Location RTK
7	Number of SVs in use, range from 00 through 12
8	HDOP
9	Orthometric height (MSL reference)
10	M: unit of measure for orthometric height is meters
11	Geoid separation
12	M: geoid separation is measured in meters
13	Age of differential GPS data record, Type 1 or Type 9. Null field when DGPS is not used.
14	Reference station ID, ranging from 0000 through 1023. A null field when any reference station ID is selected and no corrections are received ¹ .
15	The checksum data, always begins with *

¹When using OmniSTAR services, ID=100 for OmniSTAR VBS, ID=1000 for OmniSTAR HP, and ID=1008 for OmniSTAR XP.

GSA **GPS DOP and active satellites**

An example of the GSA message string is shown below. [Table A.2](#) describes the message fields.

```
$GPGSA,<1>,<2>,<3>,<3>,,,,,<3>,<3>,<3>,<4>,<5>,<6>*<7><CR><LF>
```

Table A.2 GSA message fields

Field	Meaning
0	Message ID \$GPGSA
1	Mode 1, M = manual, A = automatic
2	Mode 2, Fix type, 1 = not available, 2 = 2D, 3 = 3D
3	PRN number, 01 through 32, of satellite used in solution, up to 12 transmitted
4	PDOP-Position dilution of precision, 0.5 through 99.9
5	HDOP-Horizontal dilution of precision, 0.5 through 99.9
6	VDOP-Vertical dilution of precision, 0.5 through 99.9
7	The checksum data, always begins with *

GST Position Error Statistics

An example of the GST message string is shown below. [Table A.3](#) describes the message fields.

```
$GPGST,172814.0,0.006,0.023,0.020,273.6,0.023,0.020,0.031*6A
```

Table A.3 GST message fields

Field	Meaning
0	Message ID \$GPGST
1	UTC of position fix
2	RMS value of the pseudorange residuals; includes carrier phase residuals during periods of RTK(float) and RTK(fixed) processing
3	Error ellipse semi-major axis 1 sigma error, in meters
4	Error ellipse semi-minor axis 1 sigma error, in meters
5	Error ellipse orientation, degrees from true north
6	Latitude 1 sigma error, in meters
7	Longitude 1 sigma error, in meters
8	Height 1 sigma error, in meters
9	The checksum data, always begins with *

GSV **Satellite Information**

The GSV message string identifies the number of SVs in view, the PRN numbers, elevations, azimuths, and SNR values. An example of the GSV message string is shown below. [Table A.4](#) describes the message fields.

```
$GPGSV,4,1,13,02,02,213,,03,-3,000,,11,00,121,,14,13,172,05*67
```

Table A.4 GSV message fields

Field	Meaning
0	Message ID \$GPGSV
1	Total number of messages of this type in this cycle
2	Message number
3	Total number of SVs visible
4	SV PRN number
5	Elevation, in degrees, 90° maximum
6	Azimuth, degrees from True North, 000° through 359°
7	SNR, 00–99 dB (null when not tracking)
8–11	Information about second SV, same format as fields 4 through 7
12–15	Information about third SV, same format as fields 4 through 7
16–19	Information about fourth SV, same format as fields 4 through 7
20	The checksum data, always begins with *

HDT **Heading from True North**

The HDT string is shown below, and [Table A.5](#) describes the message fields.

```
$GPHDT,123.456,T*00
```

Table A.5 Heading from true north fields

Field	Meaning
0	Message ID \$GPHDT
1	Heading in degrees
2	T: Indicates heading relative to True North
3	The checksum data, always begins with *

PTNL,AVR**Time, Yaw, Tilt, Range for Moving Baseline RTK**

The PTNL,AVR message string is shown below, and [Table A.6](#) describes the message fields.

```
$PTNL,AVR,181059.6,+149.4688,Yaw,+0.0134,Tilt,,,60.191,3,2.5,6*00
```

Table A.6 AVR message fields

Field	Meaning
0	Message ID \$PTNL,AVR
1	UTC of vector fix
2	Yaw angle in degrees
3	Yaw
4	Tilt angle in degrees
5	Tilt
6	Reserved
7	Reserved
8	Range in meters
9	GPS quality indicator: 0: Fix not available or invalid 1: Autonomous GPS fix 2: Differential carrier phase solution RTK (Float) 3: Differential carrier phase solution RTK (Fix) 4: Differential code-based solution, DGPS
10	PDOP
11	Number of satellites used in solution
12	The checksum data, always begins with *

PTNL,BPQ

Base station position and quality indicator

This message describes the base station position and its quality. It is used when the moving base antenna position and quality are required on one serial port (along with a heading message) from a receiver in heading mode, typically the SPS551H.

The PTNL,BPQ message string is shown below, and [Table A.7](#) describes the message fields.

```
$PTNL,BPQ,224445.06,021207,3723.09383914,N,12200.32620132,W,EHT-5.923,
M,5*
```

Table A.7 BPQ message fields

Field	Meaning
0	Talker ID
1	BPQ
2	UTC time of position fix, in hhmmss.ss format. Hours must be two numbers, so may be padded, for example, 7 is shown as 07.
3	UTC date of position fix, in ddmmyy format. Day must be two numbers, so may be padded, for example, 8 is shown as 08.
4	Latitude, in degrees and decimal minutes (ddmm.mmmmmmm)
5	Direction of latitude: N: North S: South
6	Longitude, in degrees and decimal minutes (dddmm.mmmmmmm). Should contain 3 digits of ddd.
7	Direction of longitude: E: East W: West
8	Height Ellipsoidal height of fix (antenna height above ellipsoid). Must start with EHT.
9	M: ellipsoidal height is measured in meters
10	GPS quality indicator: 0: Fix not available or invalid 1: Autonomous GPS fix 2: Differential SBAS, or OmniSTAR VBS 4: RTK Fixed 5: OmniSTAR XP, OmniSTAR HP, Float RTK, or Location RTK
11	The checksum data, always begins with *

PTNL,DG**L-band corrections and beacon signal strength and related information**

This message, \$PTNLDG, is a Trimble-created message. It outputs the L-band and beacon signal strength and other information.

The PTNL,DG message string is shown below, and [Table A.8](#) describes the message fields.

Example:

For beacon DG message: \$PTNLDG,44.0,33.0,287.0,100,0,4,1,0,,*3E

For L-band DG message: \$PTNLDG,124.0,10.5,1557855.0,1200,2,4,0,3,,*3C

Table A.8 DG message fields

Field	Meaning
0	Talker ID
1	Signal strength
2	SNR in db
3	Signal frequency in kHz
4	Bit rate
5	Channel number. For a beacon message, the system locks only to the primary channel. As a result, there is not more than one beacon message. The channel for beacon is 0 (so it matches the DSM 232 family of GPS receivers). For L-band messages, the channel number is 2 (so it matches the DSM 232 family of GPS receivers).
6	Tracking status: 0: Channel idle. 1: Wideband FFT search. 2: Searching for signal. 3: Channel has acquired signal. 4: Channel has locked onto signal. For beacon, this means valid RTCM has been received. For L-band, this means good data has been decoded. 5: Channel disabled.
7	Channel used. Output 1 if the RTCM is being used for outputting DGPS position. 0 otherwise. If the system is not outputting DGPS, the output is 0 also.
8	Channel tracking performance indicator. For beacon this is the word error rate, which is in percentage. For L-band, this is the time since the last sync, in tenths of seconds ranging from 0 through 255.

PTNL,GGK

Time, Position, Position Type, DOP

An example of the PTNL,GGK message string is shown below. [Table A.9](#) describes the message fields.

```
$PTNL,GGK,453049.0,0,3728.455440850,N,12215.253291068,W,3,9,2.0,EHT35.7424,M*
```

Table A.9 PTNL,GGK message fields

Field	Meaning
0	Talker ID \$PTNL
1	Message ID GGK
2	UTC time of position fix, in hhmmss.ss format. Hours must be two numbers, so may be padded, for example, 7 is shown as 07.
3	UTC date of position fix, in ddmmyy format. Day must be two numbers, so may be padded, for example, 8 is shown as 08.
4	Latitude, in degrees and decimal minutes (dddmm.mmmmmmm)
5	Direction of latitude: N: North S: South
6	Longitude, in degrees and decimal minutes (dddmm.mmmmmmm). Should contain three digits of ddd.
7	Direction of longitude: E: East W: West
8	GPS Quality indicator: 0: Fix not available or invalid 1: Autonomous GPS fix 2: RTK float solution 3: RTK fix solution 4: Differential, code phase only solution (DGPS) 5: SBAS solution – WAAS, EGNOS, MSAS 6: RTK float or RTK location 3D Network solution 7: RTK fixed 3D Network solution 8: RTK float or RTK location 2D in a Network solution 9: RTK fixed 2D Network solution 10: OmniSTAR HP/XP solution 11: OmniSTAR VBS solution 12: Location RTK solution 13: Beacon DGPS
9	Number of satellites in fix
10	Ellipsoidal height of fix (antenna height above ellipsoid). Must start with EHT.
11	M: ellipsoidal height is measured in meters
12	The checksum data, always begins with *

Note – The PTNL,GGK message is longer than the NMEA-0183 standard of 80 characters.

PTNL,PJK**Local Coordinate Position Output**

An example of the PTNL,PJK message string is shown below. [Table A.10](#) describes the message fields.

```
$PTNL,PJK,010717.00,081796,+732646.511,N,+1731051.091,E,1,05,2.7,EHT-
28.345,M*7C
```

Table A.10 PTNL,PJK message fields

Field	Meaning
0	Message ID \$PTNL,PJK
1	UTC of position fix
2	Date
3	Northing, in meters
4	Direction of Northing will always be N (North)
5	Easting, in meters
6	Direction of Easting will always be E (East)
7	GPS Quality indicator: 0: Fix not available or invalid 1: Autonomous GPS fix 2: RTK float solution 3: RTK fix solution 4: Differential, code phase only solution (DGPS) 5: SBAS solution – WAAS, EGNOS, MSAS 6: RTK Float 3D network solution 7: RTK Fixed 3D network solution 8: RTK Float 2D network solution 9: RTK Fixed 2D network solution 10: OmniSTAR HP/XP solution 11: OmniSTAR VBS solution 12: Location RTK 13: Beacon DGPS
8	Number of satellites in fix
9	DOP of fix
10	Ellipsoidal height of fix
11	M: ellipsoidal height is measured in meters
12	The checksum data, always begins with *

Note – The PTNL,PJK message is longer than the NMEA-0183 standard of 80 characters.

PTNL,VGK**Vector Information**

An example of the PTNL,VGK message string is shown below. [Table A.11](#) describes the message fields.

```
$PTNL,VGK,160159.00,010997,-0000.161,00009.985,-0000.002,3,07,1,4,M*0B
```

Table A.11 PTNL,VGK message fields

Field	Meaning
0	Message ID \$PTNL,VGK
1	UTC of vector in hhmmss.ss format
2	Date in mmddyy format
3	East component of vector, in meters
4	North component of vector, in meters
5	Up component of vector, in meters
6	GPS Quality indicator: 0: Fix not available or invalid 1: Autonomous GPS fix 2: RTK float solution 3: RTK fix solution 4: Differential, code phase only solution (DGPS) 5: SBAS solution – WAAS, EGNOS, MSAS 6: RTK Float 3D network solution 7: RTK Fixed 3D network solution 8: RTK Float 2D network solution 9: RTK Fixed 2D network solution 10: OmniSTAR HP/XP solution 11: OmniSTAR VBS solution 12: Location RTK 13: Beacon DGPS
7	Number of satellites if fix solution
8	DOP of fix
9	M: Vector components are in meters
10	The checksum data, always begins with *

PTNL,VHD**Heading Information**

An example of the PTNL,VHD message string is shown below. [Table A.12](#) describes the message fields.

```
$PTNL,VHD,030556.00,093098,187.718,-22.138,-76.929,-
5.015,0.033,0.006,3,07,2.4,M*22
```

Table A.12 PTNL,VHD message fields

Field	Meaning
0	Message ID \$PTNL,VHD
1	UTC of position in hhmmss.ss format
2	Date in mmdyy format
3	Azimuth
4	Δ Azimuth/ Δ Time
5	Vertical Angle
6	Δ Vertical/ Δ Time
7	Range
8	Δ Range/ Δ Time
9	GPS Quality indicator: 0: Fix not available or invalid 1: Autonomous GPS fix 2: RTK float solution 3: RTK fix solution 4: Differential, code phase only solution (DGPS) 5: SBAS solution – WAAS, EGNOS, MSAS 6: RTK Float 3D network solution 7: RTK Fixed 3D network solution 8: RTK Float 2D network solution 9: RTK Fixed 2D network solution 10: OmniSTAR HP/XP solution 11: OmniSTAR VBS solution 12: Location RTK 13: Beacon DGPS
10	Number of satellites used in solution
11	PDOP
12	The checksum data, always begins with *

RMC Position, Velocity, and Time

The RMC string is shown below, and [Table A.13](#) describes the message fields.

```
$GPRMC,123519,A,4807.038,N,01131.000,E,022.4,084.4,230394,003.1,W*6A
```

Table A.13 GPRMC message fields

Field	Meaning
0	Message ID \$GPRMC
1	UTC of position fix
2	Status A=active or V=void
3	Latitude
4	Longitude
5	Speed over the ground in knots
6	Track angle in degrees (True)
7	Date
8	Magnetic variation in degrees
9	The checksum data, always begins with *

ROT **Rate and Direction of Turn**

The ROT string is shown below, and [Table A.14](#) describes the message fields.

```
$GPROT,35.6,A*4E
```

Table A.14 ROT message fields

Field	Meaning
0	Message ID \$GPROT
1	Rate of turn, degrees/minutes, "-" indicates bow turns to port
2	A: Valid data V: Invalid data
3	The checksum data, always begins with *

VTG Track Made Good and Speed Over Ground

An example of the VTG message string is shown below, and [Table A.15](#) describes the message fields.

```
$GPVTG,,T,,M,0.00,N,0.00,K*4E
```

Table A.15 VTG message fields

Field	Meaning
0	Message ID \$GPVTG
1	Track made good (degrees true)
2	T: track made good is relative to true north
3	Track made good (degrees magnetic)
4	M: track made good is relative to magnetic north
5	Speed, in knots
6	N: speed is measured in knots
7	Speed over ground in kilometers/hour (kph)
8	K: speed over ground is measured in kph
9	The checksum data, always begins with *

ZDA UTC Day, Month, And Year, and Local Time Zone Offset

An example of the ZDA message string is shown below, and [Table A.16](#) describes the message fields.

```
$GPZDA,172809,12,07,1996,00,00*45
```

Table A.16 ZDA message fields

Field	Meaning
0	Message ID \$GPZDA
1	UTC
2	Day, ranging between 01 and 31
3	Month, ranging between 01 and 12
4	Year
5	Local time zone offset from GMT, ranging from 00 through ± 13 hours
6	Local time zone offset from GMT, ranging from 00 through 59 minutes
7	The checksum data, always begins with *

Fields 5 and 6 together yield the total offset. For example, if field 5 is -5 and field 6 is $+15$, local time is 5 hours and 15 minutes earlier than GMT.

GSOF Messages

In this appendix:

- [Supported message types](#)
- [General Serial Output Format](#)
- [Reading binary values](#)
- [GSOF message definitions](#)

This appendix provides information on the General Serial Output Format (GSOF) messages. GSOF messages are a Trimble proprietary format and can be used to send information such as position and status to a third-party device.

For information on how to output GSOF messages, see [Chapter 5, Configuring the Receiver Using the Keypad and Display](#).

Supported message types

This table summarizes the GSOF messages that are supported by the receiver, and shows the page that contains detailed information about each message.

Message	Description	Page
TIME	Position time	92
LLH	Latitude, longitude, height	92
ECEF	Earth-Centered, Earth-Fixed position	93
ECEF DELTA	Earth-Centered, Earth-Fixed Delta position	93
TPlane ENU	Tangent Plane Delta	93
Velocity	Velocity data	94
PDOP	PDOP info	95
SIGMA	Position Sigma info	95
SV Brief	SV Brief info	96
SV Detail	SV Detailed info	96
UTC	Current UTC time	97
BATT/MEM	Receiver battery and memory status	98
ATTITUDE	Attitude info	98
BASE POSITION AND QUALITY INDICATOR	Base station position and its quality	99

General Serial Output Format

Table B.1 Report packet 40h structure (GENOUT)

Byte	Item	Type	Value	Meaning
0	STX	CHAR	02h	Start transmission.
1	STATUS	CHAR	See Table B.2	Receiver status code.
2	PACKET TYPE	CHAR	40h	Report Packet 40h (GENOUT).
3	LENGTH	CHAR	00h–FAh	Data byte count.
4	TRANSMISSION NUMBER	CHAR		Unique number assigned to a group of record packet pages. Prevents page mismatches when multiple sets of record packets exist in output stream.
5	PAGE INDEX	CHAR	00h–FFh	Index of current packet page.
6	MAX PAGE INDEX	CHAR	00h–FFh	Maximum index of last packet in one group of records.
<i>One or more GSOF messages</i>				
	Output record type	CHAR	01h	For example, Time (Type 1 Record).
	Record length	CHAR	0Ah	Bytes in record.
<i>Various fields depending on Output record type</i>				
There can be multiple records in one GENOUT packet. There could be multiple GENOUT packets per epoch. Records may be split over two consecutive packets.				

Table B.1 Report packet 40h structure (GENOUT)

Byte	Item	Type	Value	Meaning
Length + 4	CHECKSUM	-	-	(Status + type + length + data bytes) modulo 256
Length + 5	ETX (03h)	-	-	End transmission

Each message begins with a 4-byte header, followed by the bytes of data in each packet. The packet ends with a 2-byte trailer. Byte 3 is set to 0 (00h) when the packet contains no data. Most data is transmitted between the receiver and remote device in binary format.

Table B.2 Receiver Status code

Byte number	Message	Description
Bit 0	1	Reserved
Bit 1	1	Low battery
Bit 2-7	0-63	Reserved

Reading binary values

The receivers store numbers in Motorola format. The byte order of these numbers is the opposite of what personal computers (PCs) expect (Intel format). To supply or interpret binary numbers (8-byte DOUBLES, 4-byte LONGS, and 2-byte INTEGERS), the byte order of these values must be reversed. This section contains a detailed description of the Motorola format.

INTEGER data types

The INTEGER data types (CHAR, SHORT, and LONG) can be signed or unsigned. By default, they are unsigned. All integer data types use two's complement representation. The following table lists the integer data types.

Type	# of bits	Range of values (Signed)	(Unsigned)
CHAR	8	-128 to 127	0 to 255
SHORT	16	-32768 to 32767	0 to 65535
LONG	32	-2147483648 to 2147483647	0 to 4294967295

FLOATING-POINT data types

Floating-point data types are stored in the IEEE SINGLE and DOUBLE precision formats. Both formats have a sign bit field, an exponent field, and a fraction field. The fields represent floating-point numbers in the following manner:

$$\text{Floating-Point Number} = \langle \text{sign} \rangle 1. \langle \text{fraction field} \rangle \times 2^{\langle \text{exponent field} \rangle - \text{bias}}$$

- **Sign bit field**

The sign bit field is the most significant bit of the floating-point number. The sign bit is 0 for positive numbers and 1 for negative numbers.

- **Fraction field**

The fraction field contains the fractional part of a normalized number. Normalized numbers are greater than or equal to 1 and less than 2. Since all normalized numbers are of the form 1.XXXXXXXXX, the 1 becomes implicit and is not stored in memory. The bits in the fraction field are the bits to the right of the binary point, and they represent negative powers of 2.

For example:

$$0.011 \text{ (binary)} = 2^{-2} + 2^{-3} = 0.25 + 0.125 = 0.375$$

- **Exponent field**

The exponent field contains a biased exponent; that is, a constant bias is subtracted from the number in the exponent field to yield the actual exponent. (The bias makes negative exponents possible.)

If both the exponent field and the fraction field are zero, the floating-point number is zero.

- **NaN**

A NaN (Not a Number) is a special value which is used when the result of an operation is undefined. For example, adding positive infinity to negative infinity results in a NaN.

FLOAT data type

The FLOAT data type is stored in the IEEE single-precision format which is 32 bits long. The most significant bit is the sign bit, the next 8 most significant bits are the exponent field, and the remaining 23 bits are the fraction field. The bias of the exponent is 127. The range of single-precision format values is from 1.18×10^{-38} to 3.4×10^{38} . The floating-point number is precise to 6 decimal digits.

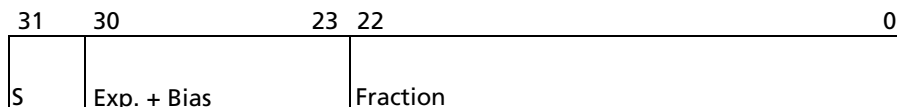

- 0 000 0000 0 000 0000 0000 0000 0000 0000 = 0.0
- 0 011 1111 1 000 0000 0000 0000 0000 0000 = 1.0
- 1 011 1111 1 011 0000 0000 0000 0000 0000 = -1.375
- 1 111 1111 1 111 1111 1111 1111 1111 1111 = NaN

DOUBLE

The DOUBLE data type is stored in the IEEE double-precision format which is 64 bits long. The most significant bit is the sign bit, the next 11 most significant bits are the exponent field, and the remaining 52 bits are the fractional field. The bias of the exponent is 1023. The range of single precision format values is from 2.23×10^{-308} to 1.8×10^{308} . The floating-point number is precise to 15 decimal digits.

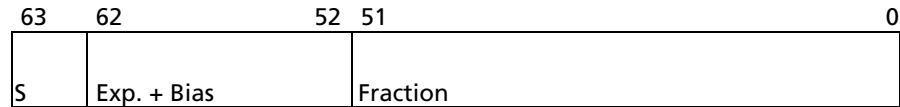

0 000 0000 0000 0000 0000 ... 0000 0000 0000 = 0.0

0 011 1111 1111 0000 0000 ... 0000 0000 0000 = 1.0

1 011 1111 1110 0110 0000 ... 0000 0000 0000 = -0.6875

1 111 1111 1111 1111 1111 ... 1111 1111 1111 = NaN

GSOFF message definitions

When GSOFF output is enabled, the following messages can be generated.

TIME

This message describes position time information. It contains the following data:

- GPS time, in milliseconds of GPS week
- GPS week number
- Number of satellites used
- Initialization counter

Table B.3 Time (Type 1 record)

Field	Item	Type	Value	Meaning
0	Output record type	Char	01h	Position time output record
1	Record length	Char	0Ah	Bytes in record
2–5	GPS time (ms)	Long	msecs	GPS time, in milliseconds of GPS week
6–7	GPS week number	Short	number	GPS week count since January 1980
8	Number of SVs used	Char	00h-0Ch	Number of satellites used to determine the position (0-12)
9	Position flags 1	Char	See Table B.17	Reports first set of position attribute flag values
10	Position flags 2	Char	See Table B.18	Reports second set of position attribute flag values
11	Initialized number	Char	00h-FFh	Increments with each initialization (modulo 256)

LLH

This message describes latitude, longitude, and height. It contains the following data:

- WGS-84 latitude and longitude, in radians
- WGS-84 height, in meters

Table B.4 Latitude, longitude, height (Type 2 record)

Field	Item	Type	Value	Meaning
0	Output record type	Char	02h	Latitude, longitude, and height output record
1	Record length	Char	18h	Bytes in record
2–9	Latitude	Double	Radians	Latitude from WGS-84 datum
10–17	Longitude	Double	Radians	Longitude from WGS-84 datum
18–25	Height	Double	Meters	Height from WGS-84 datum

ECEF

This message describes the ECEF position. It contains the following data:

- Earth-Centered, Earth-Fixed X, Y, Z coordinates, in meters

Table B.5 ECEF position (Type 3 record)

Field	Item	Type	Value	Meaning
0	Output record type	Char	03h	Earth-Centered, Earth-Fixed (ECEF) position output record
1	Record length	Char	18h	Bytes in record
2–9	X	Double	Meters	WGS-84 ECEF X-axis coordinate
10–17	Y	Double	Meters	WGS-84 ECEF Y-axis coordinate
18–25	Z	Double	Meters	WGS-84 ECEF Z-axis coordinate

ECEF DELTA

This message describes the ECEF Delta position. It contains the following data:

- Earth-Centered, Earth-Fixed X, Y, Z deltas between the rover and base position, in meters.

Table B.6 ECEF Delta (Type 6 record)

Field	Item	Type	Value	Meaning
0	Output record type	Char	06h	Earth-Centered, Earth-Fixed (ECEF) Delta output record
1	Record length	Char	18h	Bytes in record
2–9	Delta X	Double	Meters	ECEF X-axis delta between rover and base station positions
10–17	Delta Y	Double	Meters	ECEF Y-axis delta between rover and base station positions
18–25	Delta Z	Double	Meters	ECEF Z-axis delta between rover and base station positions

TPlane ENU

This message contains Tangent Plane Delta information. It contains the following data:

- North, East, and Up deltas of the vector from the base to the rover (in meters) projected onto a plane tangent to the WGS-84 ellipsoid at the base receiver.

Note – *These records are only output if a valid DGPS/RTK solution is computed.*

Table B.7 TPlane ENU (Type 7 record)

Field	Item	Type	Value	Meaning
0	Output record type	Char	07h	Tangent Plane Delta output record
1	Record length	Char	18h	Bytes in record

Table B.7 TPlane ENU (Type 7 record)

Field	Item	Type	Value	Meaning
2-9	Delta east	Double	meters	East component of vector from base station to rover, projected onto a plane tangent to the WGS-84 ellipsoid at the base station
10-17	Delta north	Double	meters	North component of tangent plane vector
18-25	Delta up	Double	meters	Difference between ellipsoidal height of tangent plane at base station and a parallel plane passing through rover point

Velocity

This message provides velocity information. It contains the following data:

- Horizontal velocity, in meters per second
- Vertical velocity, in meters per second
- Heading, in radians, referenced to WGS-84 True North

Table B.8 Velocity (Type 8 record)

Field	Item	Type	Value	Meaning
0	Output record type	Char	08h	Velocity data output record
1	Record length	Char	0Dh	Bytes in record
2	Velocity flags	Char	See Table B.20	Velocity status flags
3-6	Speed	Float	Meters per second	Horizontal speed
7-10	Heading	Float	Radians	True north heading in the WGS-84 datum
11-14	Vertical velocity	Float	Meters per second	Vertical velocity

PDOP

This message describes the PDOP information. It contains the following data:

- PDOP
- HDOP
- VDOP
- TDOP

Table B.9 PDOP (Type 9 record)

Field	Item	Type	Value	Meaning
0	Output record type	Char	09h	PDOP information output record
1	Record length	Char	10h	Bytes in record
2–5	PDOP	Float		Positional Dilution of Precision
6–9	HDOP	Float		Horizontal Dilution of Precision
10–13	VDOP	Float		Vertical Dilution of Precision
14–17	TDOP	Float		Time Dilution of Precision

SIGMA

This message describes the Position Sigma information. It contains the following data:

- Position RMS
- Sigma east, in meters
- Sigma north, in meters
- Sigma up, in meters
- Covariance east-north
- Error Ellipse Semi-major axis, in meters
- Error Ellipse Semi-minor axis, in meters
- Orientation of Semi-major axis in degrees from True North
- Unit variance
- Number of epochs

Table B.10 Sigma (Type 12 record)

Field	Item	Type	Value	Meaning
0	Output record type	Char	0Ch	Position sigma information output record
1	Record length	Char	26h	Bytes in record
2–5	Position RMS	Float		Root means square of position error calculated for overdetermined positions
6–9	Sigma east	Float	Meters	
10–13	Sigma north	Float	Meters	
14–17	Covar. east-north	Float	number	Covariance east-north (dimensionless)

Table B.10 Sigma (Type 12 record) (continued)

Field	Item	Type	Value	Meaning
18–21	Sigma up	Float	Meters	
22–25	Semi-major axis	Float	Meters	Semi-major axis of error ellipse
26–29	Semi-minor axis	Float	Meters	Semi-minor axis of error ellipse
30–33	Orientation	Float	degrees	Orientation of semi-minor axis, clockwise from True North
34–37	Unit variance	Float		Valid only for over-determined solutions. Unit variance should approach 1.0 value. A value of less than 1.0 indicates that apriori variances are too pessimistic.
30–39	Number of epochs	short	count	Number of measurement epochs used to compute the position. Could be greater than 1 for positions subjected to static constraint. Always 1 for kinematic.

SV Brief

This message provides brief satellite information. It contains the following data:

- Number of satellites tracked
- The PRN number of each satellite
- Flags indicating satellite status

Table B.11 SV brief (Type 13 record)

Field	Item	Type	Value	Meaning
0	Output record type	Char	0Dh	Brief satellite information output record
1	Record length	Char		Bytes in record
2	Number of SVs	Char	00h-18h	Number of satellites included in record ¹
The following bytes are repeated for Number of SVs				
	PRN	Char	01h-20h	Pseudorandom number of satellites (1-32)
	SV Flags1	Char	See Table B.21	First set of satellite status bits
	SV Flags2	Char	See Table B.22	Second set of satellite status bits

¹Includes all tracked satellites, all satellites used in the position solution, and all satellites in view.

SV Detail

This message provides detailed satellite information. It contains the following data:

- Number of satellites tracked
- The PRN number of each satellite
- Flags indicating satellite status
- Elevation above horizon, in degrees
- Azimuth from True North, in degrees

- Signal-to-noise ratio (SNR) of L1 signal
- Signal-to-noise ratio (SNR) of L2 signal

Table B.12 SV detail (Type 14 record)

Field	Item	Type	Value	Meaning
0	Output record type	Char	0Eh	Detailed satellite information output record
1	Record length	Char	1 + 8x(number of SVs)	Bytes in record
2–9	Number of SVs	Char	00h-18h	Number of satellites included in record ¹
The following bytes are repeated for Number of SVs				
	PRN	Char	01h-20h	Pseudorandom number of satellites (1–32)
	Flags1	Char	See Table B.21	First set of satellite status bits
	Flags2	Char	See Table B.22	Second set of satellite status bits
	Elevation	Char	Degrees	Angle of satellite above the horizon
	Azimuth	Short	Degrees	Azimuth of satellite from True North
	SNR L1	Char	dB * 4	Signal-to-noise ratio of L1 signal (multiplied by 4) ²
	SNR L2	Char	dB * 4	Signal-to-noise ratio of L2 signal (multiplied by 4) ²

¹Includes all tracked satellites, all satellites used in the position solution, and all satellites in view.

²The SNR L1 and SNR L2 items are set to zero for satellites that are not tracked on the current frequency.

UTC

This message describes current time information. It contains the following data:

- GPS time, in milliseconds of GPS week
- GPS week number
- GPS to UTC time offset, in seconds

Table B.13 UTC (Type 16 record)

Field	Item	Type	Value	Meaning
0	Output record type	Char	10h	
1	Record length	Char	09h	Bytes in record
2–5	GPS millisecond of week	Long	msecs	Time when packet is sent from the receiver, in GPS milliseconds of week
6–7	GPS week number	Short	number	Week number since start of GPS time
8–9	UTC offset	Short	seconds	GPS to UTC time offset
10	Flags	Char	See Table B.19	Flag bits indicating validity of Time and UTC offsets

Batt/Mem

This message provides information relating to the receiver battery and memory. It contains the following data:

- Remaining battery power
- Remaining memory

Table B.14 Batt/Mem (Type 37 record)

Field	Item	Type	Value	Meaning
0	Output record type	Char	25h	
1	Record length	Char	0Ah	Bytes in record
2–3	Battery capacity	Unsigned short	percentage	Remaining battery capacity in percentage
4–11	Remaining memory	Double	hours	Estimated remaining data logging time in hours

Attitude

This message provides attitude information relating to the vector between the Heading antenna and the Moving Base antenna. It contains the following data:

- Tilt or vertical angle, in radians, from the Heading antenna to the Moving Base antenna relative to a horizontal plane through the Heading antenna
- Heading or yaw, in radians, relative to True North
- Range or slope distance between the Heading antenna and the Moving Base antenna

Table B.15 Attitude (Type 27 record)

Field	Item	Type	Value	Meaning
0	Output record type	Char	1Bh	Attitude information
1	Record length	Char	2Ah	Bytes in record
2–5	GPS time	Long	msecs	GPS time in milliseconds of GPS week
6	Flags	Char	See Table B.23	Flag bits indicating validity of attitude components
7	Number of SVs used	Char	00h–0Ch	Number of satellites used to calculate attitude
8	Calculation mode	Char	See Table B.24	Positioning mode
9	Reserved			Reserved
10–17	Tilt	Double	radians	Tilt relative to horizontal plane
18–25	Yaw	Double	radians	Rotation about the vertical axis relative to True North
26–33	Reserved			Reserved
34–41	Range	Double	meters	Distance between antennas
42–43	PDOP	Short	0.1	Position Dilution of Precision

BASE POSITION AND QUALITY INDICATOR

This message describes the base station position and its quality. It is used when the moving base antenna position and quality are required on one serial port (along with a heading message) from a receiver in heading mode, typically the SPS551H.

Table B.16 Base position and quality indicator (Type 41 record)

Field	Item	Type	Value	Meaning
0	Output record type	Char	01h	Position time output record
1	Record length	Char	0Ah	Bytes in record
2–5	GPS time (ms)	Long	msecs	GPS time, in milliseconds of GPS week
6–7	GPS week number	Short	number	GPS week count since January 1980
8	Latitude	Double	Radians	The WGS-84 latitude, in radians, of the moving base antenna
9	Longitude	Double	Radians	The WGS-84 longitude, in radians, of the moving base antenna
10	Height	Double	Meters	The WGS-84 height, in meters, of the moving base antenna
11	Quality indicator	Char	See Table B.16	The quality of the base station position: 0: Fix not available or invalid 1: Autonomous GPS fix 2: Differential SBAS or OmniSTAR VBS 4: RTK Fixed 5: OmniSTAR XP, OmniSTAR HP, Float RTK, or Location RTK

Flags

Table B.17 Position flags 1: bit values

Bit	Meaning
0	New position 0: No. 1: Yes.
1	Clock fix calculated for current position 0: No. 1: Yes.
2	Horizontal coordinates calculated this position 0: No. 1: Yes.
3	Height calculated this position 0: No. 1: Yes.
4	Weighted position 0: No. 1: Yes.
5	Overdetermined position 0: No. 1: Yes.
6	Ionosphere-free position 0: No. 1: Yes.
7	Position uses filtered L1 pseudoranges 0: No. 1: Yes.

Table B.18 Position flags 2: bit values

Bit	Meaning
0	Differential position 0: Differential position is an autonomous or a WAAS solution. 1: Position is a differential solution.
1	Differential position method 0: Code 1: Phase including RTK, HP or XP OmniSTAR (VBS is not derived from Phase).
2	Differential position method 0: Code (DGPS) or a float position (RTK). Uncorrected position is Autonomous (if bit 0 = 0). 1: Position is fixed integer phase position (RTK). Uncorrected position is WAAS (if bit 0 = 0).
3	OmniSTAR solution 0: Not active 1: OmniSTAR differential solution (including HP, XP, and VBS)
4	Position determined with static as a constraint 0: No. 1: Yes.
5	Position is network RTK solution 0: No. 1: Yes.
6	Position is Location RTK 0: No. 1: Yes.
7	Position is Beacon DGPS 0: No. 1: Yes

Table B.19 Flags: Bit values

Bit	Meaning
0	Time information (week and millisecond of week) validity 0: Not valid 1: Valid
1	UTC offset validity 0: Not valid 1: Valid

Table B.20 Velocity flags: Bit values

Bit	Meaning
0	Velocity data validity 0: Not valid 1: Valid
1	Velocity computation 0: Computed from doppler 1: Computed from consecutive measurements
2-7	Reserved (set to zero)

Table B.21 SV flags: 1 bit values

Bit	Meaning
0	Satellite Above Horizon 0: No. 1: Yes.
1	Satellite Currently Assigned to a Channel (trying to track) 0: No. 1: Yes.
2	Satellite Currently Tracked on L1 Frequency 0: No. 1: Yes.
3	Satellite Currently Tracked on L2 Frequency 0: No. 1: Yes.
4	Satellite Reported at Base on L1 Frequency 0: No. 1: Yes.
5	Satellite Reported at Base on L2 Frequency 0: No. 1: Yes.
6	Satellite Used in Position 0: No. 1: Yes.
7	Satellite Used in Current RTK Process (Search, Propagate, Fix Solution) 0: No. 1: Yes.

Table B.22 SV flags: 2 bit value

Bit	Meaning
0	Satellite Tracking P-Code on L1 Band 0: No. 1: Yes.
1	Satellite Tracking P-Code on L2 Band 0: No. 1: Yes.
2-7	Reserved. Set to zero.

Table B.23 Attitude flags

Bit	Meaning
0	Calibrated 0: No. 1: Yes.
1	Tilt valid 0: No. 1: Yes.
2	Yaw valid 0: No. 1: Yes.
3	Reserved
4	Range valid 0: No. 1: Yes.
5–7	Reserved

Table B.24 Attitude calculation flags

Bit	Meaning
0	0: No position 1: Autonomous position 2: RTK/Float position 3: RTK/Fix position 4: DGPS position

Adding UHF Internal Radio Frequencies

In this appendix:

- Adding receive frequencies for the 450 MHz internal receive radio

If you have the optional internal 450 MHz receive radio in your GPS receiver, use the WinFlash utility to add the relevant *receive* frequencies to the default list of frequencies. To install the WinFlash utility, see [Installing the WinFlash utility, page 110](#).

You can also use the web interface to add and manage receive 450 MHz frequencies.

Adding receive frequencies for the 450 MHz internal receive radio

1. Start the WinFlash utility. The *Device Configuration* screen appears.
2. From the *Device type* list, select the appropriate receiver.
3. From the *PC serial port* field, select the serial (COM) port on the computer that the receiver is connected to.
4. Click **Next**. The *Operation Selection* dialog appears. The *Operations* list shows all of the supported operations for the selected device. A description of the selected operation is shown in the *Description* field.
5. Select *Configure Radio Settings* and then click **Next**. The *Internal Transceiver Configuration* dialog appears:
6. In the *Wireless Format* group, select the appropriate channel and wireless mode. The Wireless mode must be the same for all radios in your network.
7. In the *Specify Frequency* field, enter the frequency you want to add.
8. Click **Add**. The new frequency appears in the *Selected Frequencies* list.

Note – The programmed frequencies must conform to the channel spacing and minimum tuning requirements for the radio. To view this information, click **Radio Info**. You can select 12.5 kHz or 25 kHz channel spacing. All radios in your network must use the same channel spacing.

9. Once you have configured all the frequencies that you require, click **OK**. The WinFlash utility updates the receiver radio frequencies and then restarts the receiver.

Frequency Selection

You have connected to a SPSx61 Internal

Frequency Band: 410.0 - 470.0 MHz

Wireless Format: 6 - 462.125 MHz

Current Channel: 6 - 462.125 MHz

Wireless Mode: TRIMTALK 450S at 9600 bps

Note: Wireless mode must be common among all radios in your network.

Channel Frequency

Specify Frequency: 462.12500 MHz

Selected Frequencies:

Channel	Frequency
1	410.00000
2	440.00000
3	470.00000
4	439.86250
5	439.98750
6	462.12500

Setting UHF reception radio frequencies using the web interface

To enter your own Receive (Rx) frequency using the web interface:

1. Select the *Radio* menu.
2. Select the *Frequency Management* submenu:

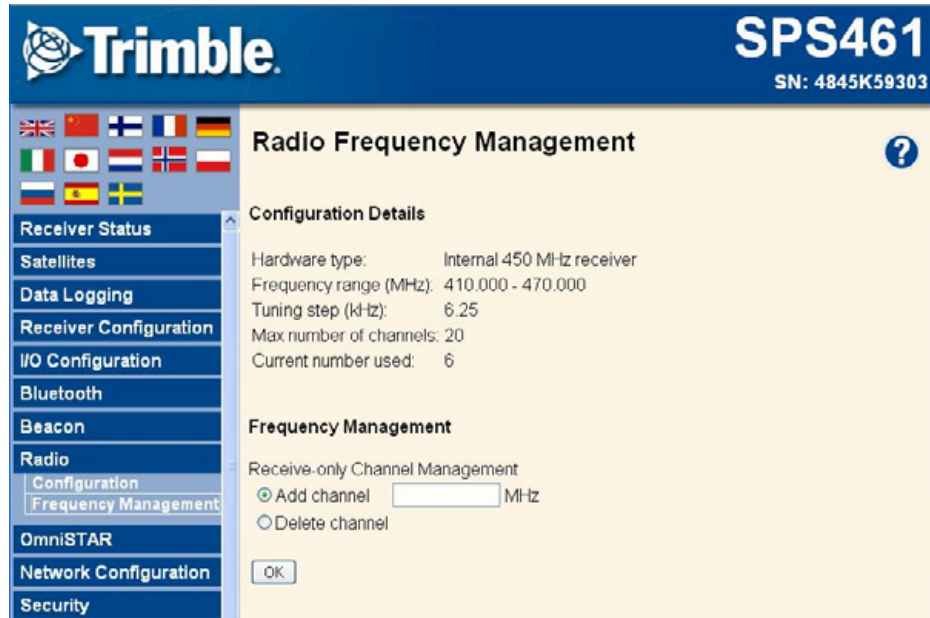

3. Make a note of the details shown in the *Frequency range* and *Tuning step* fields. Any new frequencies must be within the range shown and must also be a multiple of the Khz shown in the *Tuning step* field.
4. Select the *Add Channel* option and then enter the new channel frequency.
5. Click **OK**.

To delete a channel frequency:

1. Select the *Delete channel* option.
2. Select a channel to delete from the list that appears.

You cannot add or delete Transmit channels using the web interface.

Real-Time Data and Services

In this appendix:

- Login authentication

Login authentication

If you interface to the receivers using binary commands over serial communications, you may need login authentication. This has been added to most receiver models that run firmware version 3.30 or later.

If your utilities such as the WinFlash utility or the Configuration ToolBox software do not work with the receivers running firmware version 3.30 or later, go to the Trimble website and then download the latest versions of these utilities. If your own application software no longer communicates with the receiver, please contact Trimble Support for information about how to use the receiver in these cases.

Upgrading the Receiver Firmware

In this appendix:

- [The WinFlash utility](#)
- [Upgrading the receiver firmware](#)
- [Forcing the receiver into Monitor mode](#)

The GPS receiver is supplied with the latest version of the receiver firmware already installed. If a later version of the firmware becomes available, use the WinFlash utility to upgrade the firmware on your receiver.

You can also upgrade the receiver through the web interface (see [Configuring the receiver using a web browser, page 37](#)). If your receiver has access to the Internet, then whenever Trimble releases new firmware your receiver will check and display the new firmware version number in the Web browser. You can then decide to install the newer firmware from the Web browser.

Firmware updates are available to download from the Trimble website. Go to www.trimble.com/support.shtml and select the link to the receiver that you need updates for and then click Downloads.

The WinFlash utility

The WinFlash utility communicates with Trimble products to perform various functions including:

- installing software, firmware, and option upgrades
- running diagnostics (for example, retrieving configuration information)
- configuring radios

For more information, online help is also available when using the WinFlash utility.

Note – *The WinFlash utility runs on Microsoft Windows 95, 98, Windows NT®, 2000, Me, or XP operating systems.*

Installing the WinFlash utility

You can install the WinFlash utility from the *Trimble SPS GPS Receiver CD*, or from the Trimble website.

To install the WinFlash utility from the CD:

1. Insert the disk into the CD drive on your computer.
2. From the main menu select *Install individual software packages*.
3. Select *Install WinFlash*.
4. Follow the on-screen instructions.

The WinFlash utility guides you through the firmware upgrade process, as described below. For more information, refer to the WinFlash Help.

Upgrading the receiver firmware

1. Start the WinFlash utility. The *Device Configuration* screen appears.
2. From the *Device type* list, select your receiver.
3. From the *PC serial port* field, select the serial (COM) port on the computer that the receiver is connected to.
4. Click **Next**.

The *Operation Selection* screen appears. The *Operations* list shows all of the supported operations for the selected device. A description of the selected operation is shown in the *Description* field.

5. Select *Load GPS software* and then click **Next**.

The *GPS Software Selection* window appears. This screen prompts you to select the software that you want to install on the receiver.

6. From the *Available Software* list, select the latest version and then click **Next**.

The *Settings Review* window appears. This screen prompts you to connect the receiver, suggests a connection method, and then lists the receiver configuration and selected operation.

7. If all is correct, click **Finish**.

Based on the selections shown above, the *Software Upgrade* window appears and shows the status of the operation (for example, **Establishing communication with <your receiver>. Please wait.**)

8. Click **OK**.

The *Software Upgrade* window appears again and states that the operation was completed successfully.



9. To select another operation, click **Menu**; to quit, click **Exit**.

If you click **Exit**, the system prompts you to confirm.

10. Click **OK**.

Forcing the receiver into Monitor mode

If the receiver will not go into Monitor mode to load new firmware, complete the following steps:

1. Turn off the receiver.
2. Press and hold  while turning on the receiver.
3. Continue to hold the  button as the display shows the countdown timer.
4. Once the display shows **Remote Monitor Active:1**, release the  button.
5. The receiver is forced into Monitor mode and you can load the new firmware.

Troubleshooting

In this appendix:

- [Receiver issues](#)

Use this appendix to identify and solve common problems that may occur with the receiver.

Please read this section before you contact Technical Support.

Receiver issues

This section describes some possible receiver issues, possible causes, and how to solve them.

Issue	Possible cause	Solution
The receiver does not turn on.	External power is too low.	Check the charge on the external battery and, if applicable, check the fuse.
	Internal power is too low.	Check the charge on the internal battery.
	External power is not properly connected.	Check that the Lemo connector or 26-pin adaptor is seated correctly, and that the cable is secured to the receiver. Check for broken or bent pins in the connector.
	Faulty power cable.	Check that you are using the correct cable for the port/battery. Check that the correct battery is connected to a particular port. The ports on the GPS receiver are optimized for use with different types of battery. The 26-pin connector is optimized for Trimble custom external batteries, and the Lemo port is optimized for external 12 V batteries such as car, motorcycle, or truck batteries. If the wrong type of battery is connected to a port, it is likely that it will cut off earlier than normal. Check pinouts with a multimeter to ensure internal wiring is intact.
The receiver is not responding.	Receiver needs a soft reset.	Turn off the receiver and then turn it back on again.
	Receiver needs a full reset.	Press  for 35 seconds.
Rover receiver is not receiving radio.	Incorrect over air baud rates between reference and rover.	Connect to the rover receiver radio, and make sure that it has the same setting as the reference receiver. The SCS900 software automatically configures the over-the-air baud rate to 9600.
	Incorrect port settings between roving external radio and receiver.	If the radio is receiving data and the receiver is not getting radio communications, use the SCS900 software to check that the port settings are correct.
	The radio antenna cable and GPS antenna cable are not correctly connected.	Make sure that the external radio antenna cable is connected between the TNC connector marked RADIO and the radio antenna.
The receiver is not receiving satellite signals	The GPS antenna is connected to the wrong antenna connector.	Make sure that the GPS antenna cable is tightly seated in the GPS antenna connection on the receiver and not connected to the wrong/radio antenna connector.
	The GPS antenna cable is loose.	Make sure that the GPS antenna cable is tightly seated in the GPS antenna connection on the GPS antenna.
	The cable is damaged.	Check the cable for any signs of damage. A damaged cable can inhibit signal detection from the antenna at the receiver.
	The GPS antenna is not in clear line of sight to the sky.	<ul style="list-style-type: none"> Make sure that the GPS antenna is located with a clear view of the sky. Restart the receiver as a last resort (turn off and then turn it on again).

Issue	Possible cause	Solution
The message PC Loader in Control appears on the front panel	The WinFlash utility is in use.	Complete the WinFlash task and then exit the utility.
	The WinFlash utility was started then the data cable was disconnected.	Plug the data cable back in and then restart the receiver.
	No apparent reason.	<ul style="list-style-type: none"> • If the WinFlash utility is not in use, turn off the receiver using the Power key. • If that does not turn it off, apply external DC power and hold down the Power key for 60 seconds.
The message Remote Monitor active appears on the front panel	Internet software	<ul style="list-style-type: none"> • If possible, turn off the receiver. • If possible, reload the current firmware. • If the above solutions do not resolve this, leave the receiver on with no external power, so the internal battery completely discharges. Then, turn on the receiver.

Drawings

In this appendix:

- [Back view](#)
- [Side view](#)

The drawings in this appendix show the dimensions of the receiver. Refer to these drawings if you need to build mounting brackets and housings for the receiver.

The dimensions shown in these drawings are inches, with millimeters shown in brackets.

Back view

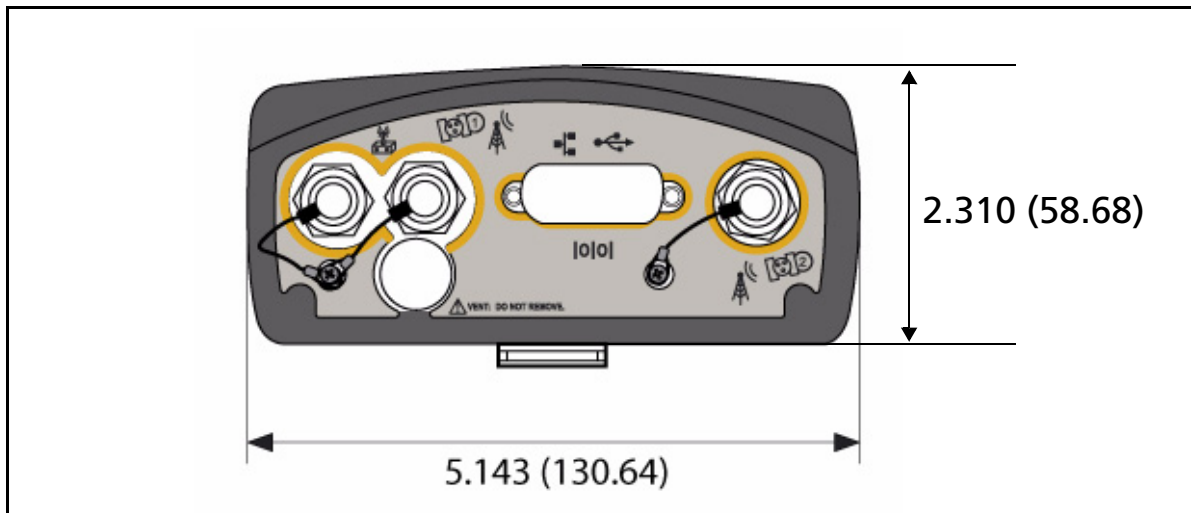

Side view

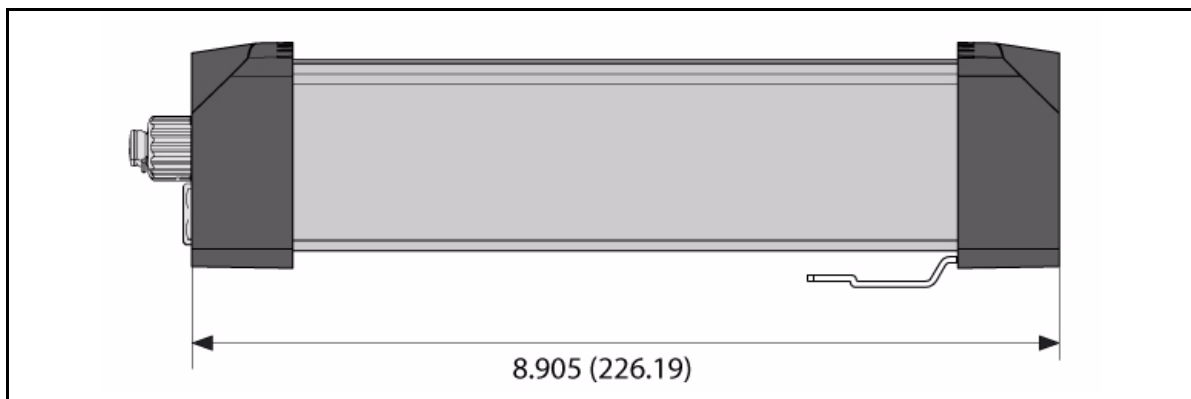

Receiver Connector Pinout Information

In this appendix:

- [Modem multi-function port](#)
- [1PPS and ASCII time tag](#)
- [ASCII time tag](#)
- [26-Pin D-sub connector wiring chart \(P/N 60789-00\)](#)
- [26-Pin D-sub connector wiring chart \(P/N 65791-00\)](#)

The receivers have a wide range of interfacing options. There are a large number adaptors and cables available from Trimble that provide most of the common interfacing combinations.

The receiver has one connector:

- a high-density 26-pin D-sub connector

Modem multi-function port

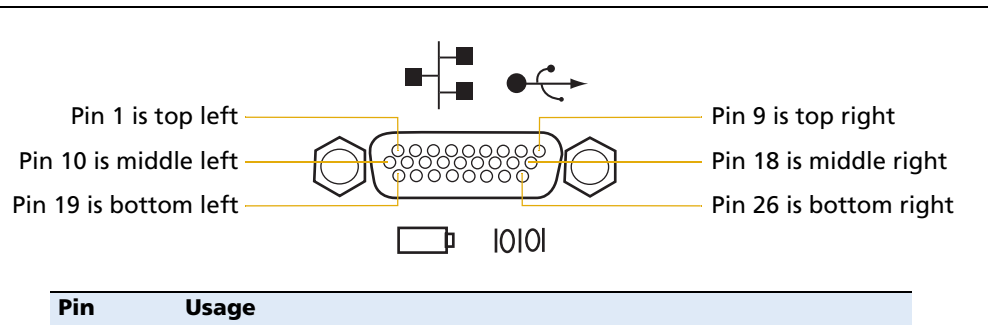

Pin	Usage
1	RS-232 Modem port data terminal ready (DTR)
2	RS-232 Modem port clear to send (CTS)
3	RS-232 Modem port Data Set Ready (DSR)
4	RS-232 Modem port Data Carrier Detect (DCD)
5	RS-232 Modem port Ring Indicator (RI)
6	GND
7	RS-232 Modem port 2 Transmit Data (TX)
8	RS-232 Modem port 2 Receive Data (RX)
9	USB+
10	Ethernet Ground (ET_GND RJ45 Pin 4)
11	RS-232 Modem port Ready to Send (TX)
12	RS-232 Modem port Transmit Data (TX)
13	Ethernet Ground (GND RJ45 Pin 5)
14	Ethernet Ground (GND RJ45 Pin 8)
15	USB ID
16	Ethernet Receive Data - (RD-, RJ45 Pin 6)
17	Ethernet Transmit Data - (TD-, RJ45 Pin 2)
18	USB-
19	USB Power
20	1PPS
21	RS-232 Modem Port Receive Data (RX)
22	Ethernet Ground (GND RJ45 Pin 7)
23	GND
24	DC Power In 11 V DC to 28 V DC
25	Ethernet Receive Data+ (RD+, RJ45 Pin 3)
26	Ethernet Transmit Data+ (TD+, RJ45 Pin 1)

1PPS and ASCII time tag

The SPSx61 receiver can output a 1 pulse-per-second (1PPS) time strobe and an associated time tag message. The time tags are output on a user-selected port.

The leading edge of the pulse coincides with the beginning of each UTC second. The pulse is driven between nominal levels of 0.0 V and 5.0 V (see [Figure H.1](#)). The leading edge is positive (rising from 0 V to 5 V).

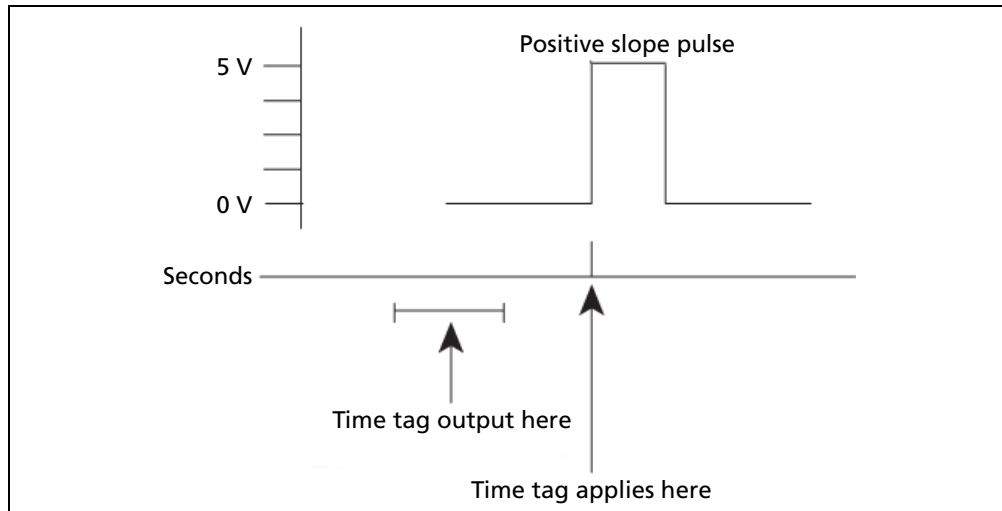

Figure H.1 Time tag relation to 1PPS wave form

The pulse is about 8 microseconds wide, with rise and fall times of about 100 nsec. Resolution is approximately 40 nsec, but the following external factor limits accuracy to approximately ± 1 microsecond:

- Antenna cable length
Each meter of cable adds a delay of about 2 nsec to satellite signals, and a corresponding delay in the 1PPS pulse.

1PPS is available on pin 20 on the back connector of the receiver. If you have applications that require 1PPS, Trimble recommends that you use cable P/N 60789-00 because it has the following connectors:

- D9 port for modem 1/serial 2.
- D9 port for modem 2/serial 3. Pin 9 on this D9 port has 1PPS.
- BNC connector for 1PPS.
- Ethernet male plug for connection to receiver.
- USB plug.
- DC jack for supplying power to the receiver.

ASCII time tag

Each time tag is output about 0.5 second before the corresponding pulse. Time tags are in ASCII format on a user-selected serial port. The format of a time tag is:

UTC *yy.mm.dd hh:mm:ss ab*

Where:

- UTC is fixed text.
- *yy.mm.dd* is the year, month, and date.
- *hh:mm:ss* is the hour (on a 24-hour clock), minute, and second. The time is in UTC, not GPS.
- *a* is an integer number representing the position-fix type:
 - 1 = time only
 - 2 = 1D & time
 - 3 = currently unused
 - 4 = 2D & time
 - 5 = 3D & time
- *b* is the number of GPS satellites being tracked.
- Each time tag is terminated by a *carriage return, line feed* sequence. A typical printout looks like:

UTC 02.12.21 20:21:16 56

UTC 02.12.21 20:21:17 56

UTC 02.12.21 20:21:18 56

Note – *If the receiver is not tracking satellites, the time tag is based on the receiver clock. In this case, a and b are represented by “?”. The time readings from the receiver clock are less accurate than time readings determined from the satellite signals.*

26-Pin D-sub connector wiring chart (P/N 60789-00)

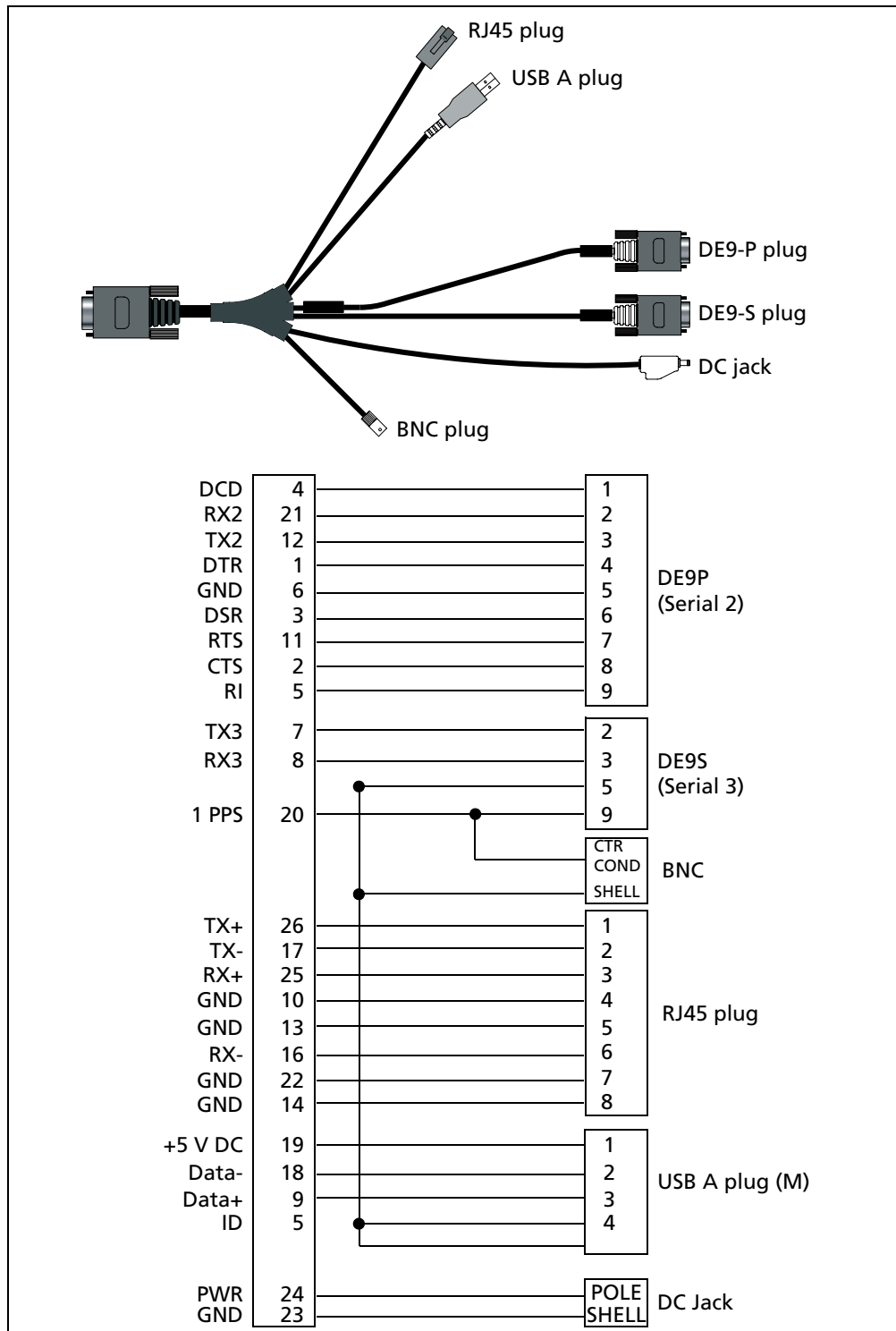

26-Pin D-sub connector wiring chart (P/N 65791-00)

This cable has Ethernet, two serial ports, and DC power. 1PPS is on Serial Port 3.

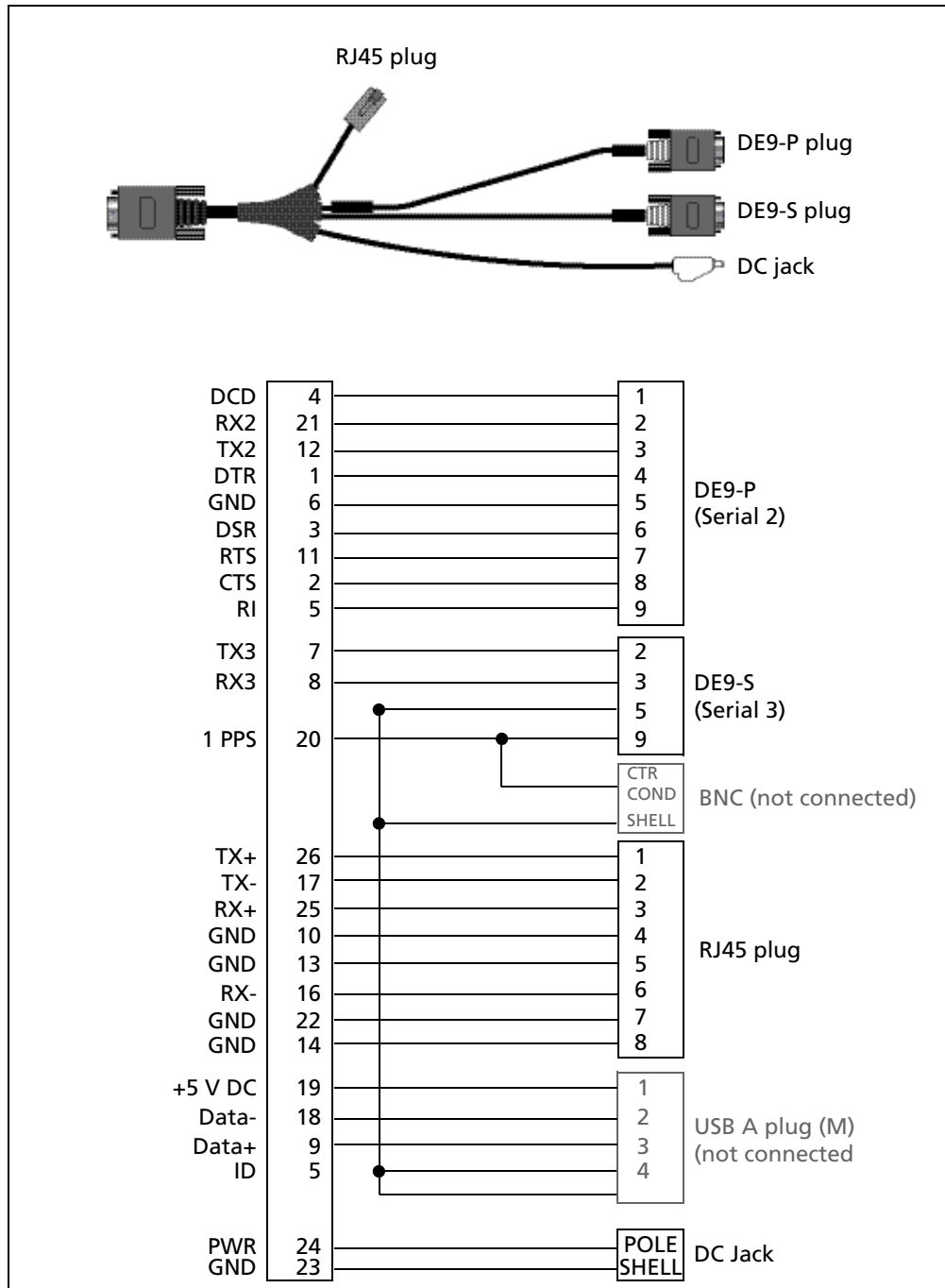

Glossary

IPPS	Pulse-per-second. Used in hardware timing. A pulse is generated in conjunction with a time stamp. This defines the instant when the time stamp is applicable.
almanac	A file that contains orbit information on all the satellites, clock corrections, and atmospheric delay parameters. The almanac is transmitted by a GPS satellite to a GPS receiver, where it facilitates rapid acquisition of GPS signals when you start collecting data, or when you have lost track of satellites and are trying to regain GPS signals. The orbit information is a subset of the ephemeris / ephemerides data.
AutoBase	AutoBase technology uses the position of the receiver to automatically select the correct base station; allowing for one button press operation of a base station. It shortens setup time associated with repeated daily base station setups at the same location on jobsites.
base station	Also called <i>reference station</i> . A base station in construction, is a receiver placed at a known point on a jobsite that tracks the same satellites as an RTK rover, and provides a real-time differential correction message stream through radio to the rover, to obtain centimeter level positions on a continuous real-time basis. A base station can also be a part of a virtual reference station network, or a location at which GPS observations are collected over a period of time, for subsequent postprocessing to obtain the most accurate position for the location.
beacon	Source of RTCM DGPS corrections transmitted from coastal reference stations in the 283.5 to 325.0 kHz range.
BINEX	BI-nary EXchange format. BINEX is an operational binary format standard for GPS/ GLONASS / SBAS research purposes. It has been designed to grow and allow encapsulation of all (or most) of the information currently allowed for in a range of other formats.
broadcast server	An Internet server that manages authentication and password control for a network of VRS servers, and relays VRS corrections from the VRS server that you select.
carrier	A radio wave having at least one characteristic (such as frequency, amplitude, or phase) that can be varied from a known reference value by modulation.
carrier frequency	The frequency of the unmodulated fundamental output of a radio transmitter. The GPS L1 carrier frequency is 1575.42 MHz.
carrier phase	Is the cumulative phase count of the GPS or GLONASS carrier signal at a given time.
cellular modems	A wireless adaptor that connects a laptop computer to a cellular phone system for data transfer. Cellular modems, which contain their own antennas, plug into a PC Card slot or into the USB port of the computer and are available for a variety of wireless data services such as GPRS.
CMR	Compact Measurement Record. A real-time message format developed by Trimble for broadcasting corrections to other Trimble receivers. CMR is a more efficient alternative to RTCM .
CMR+	
CMRx	A real-time message format developed by Trimble for transmitting more satellite corrections resulting from more satellite signals, more constellations, and more satellites. Its compactness means more repeaters can be used on a site.
covariance	A statistical measure of the variance of two random variables that are observed or measured in the same mean time period. This measure is equal to the product of the deviations of corresponding values of the two variables from their respective means.

datum	<p>Also called <i>geodetic datum</i>. A mathematical model designed to best fit the geoid, defined by the relationship between an ellipsoid and, a point on the topographic surface, established as the origin of the datum. World geodetic datums are typically defined by the size and shape of an ellipsoid and the relationship between the center of the ellipsoid and the center of the earth.</p> <p>Because the earth is not a perfect ellipsoid, any single datum will provide a better model in some locations than in others. Therefore, various datums have been established to suit particular regions.</p> <p>For example, maps in Europe are often based on the European datum of 1950 (ED-50). Maps in the United States are often based on the North American datum of 1927 (NAD-27) or 1983 (NAD-83).</p> <p>All GPS coordinates are based on the WGS-84 datum surface.</p>
deep discharge	<p>Withdrawal of all electrical energy to the end-point voltage before the cell or battery is recharged.</p>
DGPS	<p>See real-time differential GPS.</p>
differential correction	<p>Differential correction is the process of correcting GPS data collected on a rover with data collected simultaneously at a base station. Because the base station is on a known location, any errors in data collected at the base station can be measured, and the necessary corrections applied to the rover data.</p> <p>Differential correction can be done in real-time, or after the data has been collected by postprocessing.</p>
differential GPS	<p>See real-time differential GPS.</p>
DOP	<p>Dilution of Precision. A measure of the quality of GPS positions, based on the geometry of the satellites used to compute the positions. When satellites are widely spaced relative to each other, the DOP value is lower, and position accuracy is greater. When satellites are close together in the sky, the DOP is higher and GPS positions may contain a greater level of error.</p> <p>PDOP (Position DOP) indicates the three-dimensional geometry of the satellites. Other DOP values include HDOP (Horizontal DOP) and VDOP (Vertical DOP), which indicate the accuracy of horizontal measurements (latitude and longitude) and vertical measurements respectively. PDOP is related to HDOP and VDOP as follows: $PDOP^2 = HDOP^2 + VDOP^2$</p>
dual-frequency GPS	<p>A type of receiver that uses both L1 and L2 signals from GPS satellites. A dual-frequency receiver can compute more precise position fixes over longer distances and under more adverse conditions because it compensates for ionospheric delays.</p>
EGNOS	<p>European Geostationary Navigation Overlay Service. A satellite-based augmentation system (SBAS) that provides a free-to-air differential correction service for GPS. EGNOS is the European equivalent of WAAS, which is available in the United States.</p>
elevation mask	<p>The angle below which the receiver will not track satellites. Normally set to 10 degrees to avoid interference problems caused by buildings and trees, atmospheric issues, and multipath errors.</p>
ellipsoid	<p>An ellipsoid is the three-dimensional shape that is used as the basis for mathematically modeling the earth's surface. The ellipsoid is defined by the lengths of the minor and major axes. The earth's minor axis is the polar axis and the major axis is the equatorial axis.</p>

ephemeris / ephemerides	A list of predicted (accurate) positions or locations of satellites as a function of time. A set of numerical parameters that can be used to determine a satellite's position. Available as broadcast ephemeris or as postprocessed precise ephemeris.
epoch	The measurement interval of a GPS receiver. The epoch varies according to the measurement type: for real-time measurement it is set at one second; for postprocessed measurement it can be set to a rate of between one second and one minute. For example, if data is measured every 15 seconds, loading data using 30-second epochs means loading every alternate measurement.
feature	A feature is a physical object or event that has a location in the real world, which you want to collect position and/or descriptive information (attributes) about. Features can be classified as surface or non-surface features, and again as points, lines/breaklines, or boundaries/areas.
firmware	The program inside the receiver that controls receiver operations and hardware.
GLONASS	Global Orbiting Navigation Satellite System. GLONASS is a Soviet space-based navigation system comparable to the American GPS system. The operational system consists of 21 operational and 3 non-operational satellites in 3 orbit planes.
GNSS	Global Navigation Satellite System.
GSOFF	General Serial Output Format. A Trimble proprietary message format.
HDOP	Horizontal Dilution of Precision. HDOP is a DOP value that indicates the accuracy of horizontal measurements. Other DOP values include VDOP (vertical DOP) and PDOP (Position DOP). Using a maximum HDOP is ideal for situations where vertical precision is not particularly important, and your position yield would be decreased by the vertical component of the PDOP (for example, if you are collecting data under canopy).
L1	The primary L-band carrier used by GPS and GLONASS satellites to transmit satellite data.
L2	The secondary L-band carrier used by GPS and GLONASS satellites to transmit satellite data.
L2C	A modernized code that allows significantly better ability to track the L2 frequency.
L5	The third L-band carrier used by GPS satellites to transmit satellite data. L5 will provide a higher power level than the other carriers. As a result, acquiring and tracking weak signals will be easier.
Moving Base	Moving Base is an RTK positioning technique in which both reference and rover receivers are mobile. Corrections are sent from a "base" receiver to a "rover" receiver and the resultant baseline (vector) has centimeter-level accuracy.
MSAS	MTSAT Satellite-Based Augmentation System. A satellite-based augmentation system (SBAS) that provides a free-to-air differential correction service for GPS. MSAS is the Japanese equivalent of WAAS , which is available in the United States.
multipath	Interference, similar to ghosts on an analog television screen, that occurs when GPS signals arrive at an antenna having traversed different paths. The signal traversing the longer path yields a larger pseudorange estimate and increases the error. Multiple paths can arise from reflections off the ground or off structures near the antenna.
NMEA	National Marine Electronics Association. NMEA 0183 defines the standard for interfacing marine electronic navigational devices. This standard defines a number of 'strings' referred to as NMEA strings that contain navigational details such as positions. Most Trimble GPS receivers can output positions as NMEA strings.

OmniSTAR	The OmniSTAR HP/XP service allows the use of new generation dual-frequency receivers with the OmniSTAR service. The HP/XP service does not rely on local reference stations for its signal, but utilizes a global satellite monitoring network. Additionally, while most current dual-frequency GPS systems are accurate to within a meter or so, OmniSTAR with XP is accurate in 3D to better than 30 cm.
PDOP	Position Dilution of Precision. PDOP is a DOP value that indicates the accuracy of three-dimensional measurements. Other DOP values include VDOP (vertical DOP) and HDOP (Horizontal Dilution of Precision). Using a maximum PDOP value is ideal for situations where both vertical and horizontal precision are important.
postprocessing	Postprocessing is the processing of satellite data after it has been collected, in order to eliminate error. This involves using computer software to compare data from the rover with data collected at the base station.
real-time differential GPS	Also known as <i>real-time differential correction</i> or <i>DGPS</i> . Real-time differential GPS is the process of correcting GPS data as you collect it. Corrections are calculated at a base station and then sent to the receiver through a radio link. As the rover receives the position it applies the corrections to give you a very accurate position in the field. Most real-time differential correction methods apply corrections to code phase positions. While DGPS is a generic term, its common interpretation is that it entails the use of single-frequency code phase data sent from a GPS base station to a rover GPS receiver to provide sub-meter position accuracy. The rover receiver can be at a long range (greater than 100 kms (62 miles)) from the base station.
rover	A rover is any mobile GPS receiver that is used to collect or update data in the field, typically at an unknown location.
Roving mode	Roving mode applies to the use of a rover receiver to collect data, stakeout, or control earthmoving machinery in real time using RTK techniques.
RTCM	Radio Technical Commission for Maritime Services. A commission established to define a differential data link for the real-time differential correction of roving GPS receivers. There are three versions of RTCM correction messages. All Trimble GPS receivers use Version 2 protocol for single-frequency DGPS type corrections. Carrier phase corrections are available on Version 2, or on the newer Version 3 RTCM protocol, which is available on certain Trimble dual-frequency receivers. The Version 3 RTCM protocol is more compact but is not as widely supported as Version 2.
RTK	real-time kinematic. A real-time differential GPS method that uses carrier phase measurements for greater accuracy.
SBAS	Satellite-Based Augmentation System. SBAS is based on differential GPS, but applies to wide area (WAAS/EGNOS and MSAS) networks of reference stations. Corrections and additional information are broadcast via geostationary satellites.
signal-to-noise ratio	SNR. The signal strength of a satellite is a measure of the information content of the signal, relative to the signal's noise. The typical SNR of a satellite at 30° elevation is between 47 and 50 dBHz.
skyplot	The satellite skyplot confirms reception of a differentially corrected GPS signal and displays the number of satellites tracked by the GPS receiver, as well as their relative positions.

SNR	See signal-to-noise ratio .
triple frequency GPS	A type of receiver that uses three carrier phase measurements (L1 , L2 , and L5).
UTC	Universal Time Coordinated. A time standard based on local solar mean time at the Greenwich meridian.
VRS	<p>Virtual Reference Station. A VRS system consists of GPS hardware, software, and communication links. It uses data from a network of base stations to provide corrections to each rover that are more accurate than corrections from a single base station.</p> <p>To start using VRS corrections, the rover sends its position to the VRS server. The VRS server uses the base station data to model systematic errors (such as ionospheric noise) at the rover position. It then sends RTCM correction messages back to the rover.</p>
WAAS	<p>Wide Area Augmentation System. WAAS was established by the Federal Aviation Administration (FAA) for flight and approach navigation for civil aviation. WAAS improves the accuracy and availability of the basic GPS signals over its coverage area, which includes the continental United States and outlying parts of Canada and Mexico.</p> <p>The WAAS system provides correction data for visible satellites. Corrections are computed from ground station observations and then uploaded to two geostationary satellites. This data is then broadcast on the L1 frequency, and is tracked using a channel on the GPS receiver, exactly like a GPS satellite.</p> <p>Use WAAS when other correction sources are unavailable, to obtain greater accuracy than autonomous positions. For more information on WAAS, refer to the FAA website at http://gps.faa.gov.</p> <p>The EGNOS service is the European equivalent and MSAS is the Japanese equivalent of WAAS.</p>
WGS-84	<p>World Geodetic System 1984. Since January 1987, WGS-84 has superseded WGS-72 as the datum used by GPS.</p> <p>The WGS-84 datum is based on the ellipsoid of the same name.</p>



NORTH AMERICA

Trimble Construction Division
5475 Kellenburger Road
Dayton, Ohio 45424
USA
800-538-7800 (Toll Free)
+1-937-245-5154 Phone
+1-937-233-9441 Fax

EUROPE

Trimble GmbH
Am Prime Parc 11
65479 Raunheim
GERMANY
+49-6142-2100-0 Phone
+49-6142-2100-550 Fax

ASIA-PACIFIC

Trimble Navigation
Singapore Pty Limited
80 Marine Parade Road
#22-06, Parkway Parade
Singapore 449269
SINGAPORE
+65-6348-2212 Phone
+65-6348-2232 Fax



www.trimble.com