

# Transmissometer

C-Star

## User's Guide

WET Labs, Inc.  
PO Box 518  
Philomath, OR 97370  
(541) 929-5650  
[www.wetlabs.com](http://www.wetlabs.com)





---

## Return Policy for Instruments with Anti-fouling Treatment

WET Labs cannot accept instruments for servicing or repair that are treated with anti-fouling compound(s). This includes but is not limited to tri-butyl tin (TBT), marine anti-fouling paint, ablative coatings, etc.

Please ensure any anti-fouling treatment has been removed prior to returning instruments to WET Labs for service or repair.

---

## C Star Warranty

### Standard Warranty

This unit is guaranteed against defects in materials and workmanship for two years from the original date of purchase. Warranty is void if the factory determines the unit was subjected to abuse or neglect beyond the normal wear and tear of field deployment, or in the event the pressure housing has been opened by the customer.

To return the instrument, contact WET Labs for a Return Merchandise Authorization (RMA) and ship in the original container. WET Labs is not responsible for damage to instruments during the return shipment to the factory. WET Labs will supply all replacement parts and labor and pay for return via 3<sup>rd</sup> day air shipping in honoring this warranty.

### Annual Servicing Extended Warranty

WET Labs will extend the warranty on this unit to five years if it is returned annually for servicing. This includes calibration, standard maintenance, and cleaning. Charges associated with this annual service work and shipping are the responsibility of the customer.

---

### Shipping Requirements for Warranty and Out-of-warranty Instruments

1. Please retain the original shipping material. We design the shipping container to meet stringent shipping and insurance requirements, and to keep your meter functional.
  2. To avoid additional repackaging charges, use the original box (or WET Labs-approved container) with its custom-cut packing foam and anti-static bag to return the instrument.
    - If using alternative container, use at least 2 in. of foam (NOT bubble wrap or Styrofoam “peanuts”) to fully surround the instrument.
    - Minimum repacking charge for C-Star meters: \$120.00.
  3. Clearly mark the RMA number on the outside of your shipping container and on all packing lists.
  4. Return instruments using 3<sup>rd</sup> day air shipping or better: do **not** ship via ground.
-





---

## Table of Contents

1. Theory of Operation.....	1
2. Instrument Operation .....	3
2.1 Setup .....	3
2.2 Initial Checkout.....	3
2.3 Deployment.....	3
2.4 Data Collection .....	4
2.5 Data Analysis.....	4
2.6 Upkeep and Maintenance.....	5
3. Technical Reference .....	7
3.1 Optics .....	7
3.2 Electronics.....	7
3.3 Mechanical Components.....	13
4. Specifications .....	15
4.1 Connectors .....	16
4.2 Digital Output .....	16
5. Characterization.....	17
5.1 Measurement Apparatus .....	17
5.2 Procedure .....	17
6. Calibration .....	19
Appendix: Dimensional Drawing .....	20



## 1. Theory of Operation

In general, losses of light propagating through water can be attributed to two primary causes: scattering and absorption. By projecting a collimated beam of light through the water and placing a focused receiver at a known distance away, one can quantify these losses. The ratio of light gathered by the C-Star's receiver to the amount originating at the source is known as the beam transmittance ( $T_r$ ). This is the fundamental measurement performed by the C-Star. Suspended particles, phytoplankton, bacteria and dissolved organic matter all contribute to the losses sensed by the C-Star. They, combined with the intrinsic optical properties of the water itself, govern the radiative transfer properties within the earth's natural waters. Thus, the information provided by the C-Star provides both an indication of the total concentrations of matter in the water as well as a value of the water clarity.

The beam attenuation coefficient is an absolute term to represent these losses. For a given wavelength, transmittance is related to the beam attenuation coefficient by the following transfer equation:

$$T_r = e^{-cx}$$

where  $x$  is the pathlength (10 or 25 cm) of the water volume being measured.

Figure 1 is a simple description of the C-Star configuration. The appropriate LED light source (depending on the wavelength) provides light that is focused and collimated by an aperture and lens that transmits the light within a given narrow bandwidth. The light passes through a beam splitter so that a portion of the transmitted light can be monitored by the reference detector and used in a feedback circuit to account for variations in the LED source over time as well as changes in the instrument's internal temperature. The light enters the sample volume after passing through the first pressure window, transmits the sample volume and enters the receiver optics after passing through the other pressure window. The light passes through additional focusing optics and finally strikes a silicon photodiode detector which converts the amount of received light to a corresponding 0–5 V analog output signal which represents the amount of light received.

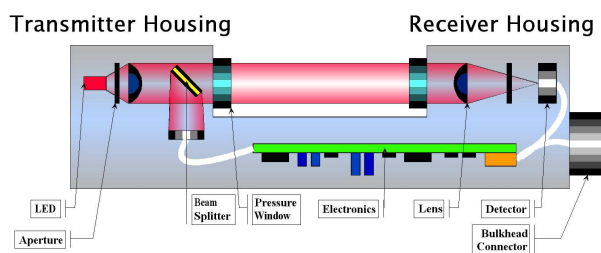

**Figure 1.** Configuration description

C-Star is optionally available with digital output. This is accomplished using a 12-bit analog-to-digital converter: full scale analog output is 5 V whereas full scale digital is 4095 counts. This manual generally refers to analog instrument's output. Details of the digital instrument output are in Section 4.1.





## 2. Instrument Operation

### 2.1 Setup

C-Star is an easy-to-use analog output instrument. Its analog output of 0–5 VDC is proportional to the amount of transmitted light that is received by the detector. The ratio of the output signal in a water sample to the signal in clean water (provided by our calibration sheet) is called the *transmittance*. The analog out and return signals may be connected to a data acquisition system of your choice. C-Star is designed to connect directly to many CTD systems and is compatible with other platforms that can provide power and accept a 0–5 VDC analog signal.

The standard C-Star delivery package includes the following:

- C-Star instrument
- A short pigtail lead with the mating connector to C-Star's bulkhead connector
- This manual
- Calibration sheet
- **Optional:** flow tube for bench-top use
- **Optional:** leak-resistant flow sleeves

### 2.2 Initial Checkout

Electrical checkout of C-Star is straightforward.

- Apply 7–15 VDC to the instrument to provide power to the LED and electronics. Ensure that positive voltage is applied to Pin 4, and common or ground is applied to Pin 1. See section 4.1 for C-Star pinouts. A 9-volt transistor radio battery makes a good power supply for bench testing. With the proper voltage applied to Pins 1 and 4, the LED should illuminate. This light is easily seen by placing a white card into the beam path.
- Connect Pin 6 (analog out) and Pin 1 (ground) to a digital multimeter. With no flow tube installed, the analog output voltage should closely agree with the air value on the calibration sheet, provided the instrument optics are clean and dry.

### 2.3 Deployment

C-Star can be deployed in either a non-pumped, open sample volume mode or a pumped configuration. If a pump is used with C-Star, you will need the optional flow tube. If you use a small pump to flush the flow cell, the recommended flow rate is 20–30 ml/sec. A good pump for this purpose is Sea-Bird Electronics' SBE-5T, a small, low powered pump that has an adjustable motor speed so flow rate can be precisely controlled.

When mounting C-Star on a cage or lowering frame, take care to electrically isolate the instrument from the metal frame and clamps. A thin sheet of rubber or dielectric tape can be used to prevent metal-to-metal contact. Hose clamps can be placed around the upper and lower housings. Although the instrument is quite strong, care should be taken not to clamp the C-Star too tightly to avoid torquing the optical path, which can cause an offset to appear in the data.

The optional 6,000 m depth rated meter comes with a zinc anode mounted near the bulkhead connector. This anode should protect C-Star from normal galvanic action. If the anode should show rapid dissipation or the instrument case itself should show signs of pitting, check the system for stray potentials. C-Star's electronics are not grounded to the case. However, ground potentials between various instruments on a cage or lowering frame may attack the pressure housing, causing corrosion.

## 2.4 Data Collection

C-Star must be connected to a host system that will receive the analog voltage output and digitize it. Many oceanographic instruments such as CTDs, radiometers, and data loggers are equipped with analog input channels with on-board A/D converters.

Adding the instrument to a CTD or other host solves several other problems. Since the data is merged with the CTD data, correlating the C-Star output with depth or time is done automatically. If one is building a logger or interface, it will obviously be necessary to provide some pressure or time reference to stamp the transmission data, tying it to the rest of the physical data.

C-Star's output is limited to a current of 10 mA or less. Its output impedance is approximately 500 ohms, which effectively limits the drive current. Therefore, the electrical signal will degrade over a long electrical wire due to the electrical resistance of the cable. For best results, the analog signal should be fed directly into an A/D converter with a high impedance input through a short cable (1–2 meters) and the digital signal should be sent up the sea cable.

## 2.5 Data Analysis

C-Star's output value increases linearly with increasing transmittance over the instrument's measurement range. The output is proportional to the amount of light received by the detector over a given pathlength. With the instrument in water, the output ( $V_{sig}$ ) should vary from a minimum value equaling the dark value (obtained by a blocked beam reading) to a maximum signal equal to the clean water reference ( $V_{ref}$ ). The ratio of the signal output to the reference output is known as transmittance and will vary from 0 to 1 or 0 to 100 percent. Transmittance is related to  $c$  by the relationship

$$Tr = e^{-cx} \quad (1)$$

where  $x$  is the pathlength through the water volume.

C-Star transmittance can be expressed as

$$Tr = (V_{sig} - V_{dark}) / (V_{ref} - V_{dark}) \quad (2)$$

where:

- $V_{sig}$  is the measured output signal
- $V_{dark}$  is the dark voltage offset for the instrument (factory-supplied).  $V_{dark}$  is obtained by blocking the C-Star's receiver and obtaining a "dark" reading of output voltage. This is an instrument offset that needs to be subtracted.
- $V_{ref}$  is the factory-supplied clean water offset.

To obtain the beam attenuation coefficient, we then solve for

$$\begin{aligned} c &= -1/x * \ln(\text{Tr}) \\ &= -1/x * \ln((V_{\text{sig}} - V_{\text{dark}}) / (V_{\text{ref}} - V_{\text{dark}})) \end{aligned} \quad (3)$$

## 2.6 Upkeep and Maintenance

C-Star is a compact instrument and its maintenance can be easily overlooked. However, the transmissometer is a precision instrument and does require a minimum of routine upkeep. After each cast or exposure of the instrument to natural water, flush the instrument with clean fresh water, paying careful attention to the pressure windows. Soapy water will cut any grease or oil accumulation. Be careful not to scratch the pressure windows when cleaning. Use lint-free tissues such as Kimwipes® for wiping the lenses.

### 2.6.1 Removing and Installing Optional Flow Tubes

Follow the steps below to remove, clean and re-install the optional flow tubes.

1. Remove the black plastic flow tubes by sliding the flow tube sleeves toward the middle of the flow tube. Lift the flow tube out.
2. Remove the O-rings.
3. Wash the flow tube with a mild detergent.
4. Rinse completely with water to ensure no soap residue is left inside the flow tube.
5. Place the tube in a protected area where it can dry out completely. Dry nitrogen can be used to blow dry the flow tube.
6. To reinstall, carefully replace the flow tube O-rings. Ensure the o-rings are not damaged in any way, as they will not seal properly. If damaged, replace with size 122 O-rings.
7. Ensure the windows are clean and dry. Since small amounts of moisture can affect the air readings, it is important to ensure that the meter is completely dry. Using dry nitrogen under very low pressure, flow the gas over the windows immediately before replacing the flow tube. This will remove any water or methanol trapped in the small grooves around the window.
8. Insert the flow tube into the meter, lining up the stainless steel cap screws with the grooves in the flow tubes. This will ensure that the feet on the ends of the flow tubes will not block the water flow. Slide the flow tube sleeves outward on both ends until the outside ring on the sleeve is flush with the C-Star body to secure the flow tube.



## 3. Technical Reference

### 3.1 Optics

C-Star's optical path begins with a LED light source located near the outside of the transmitter housing (Figure 2). The light from the LED (shown as a blue line) is projected on a small aperture and is then collimated by a 38 mm lens. A small portion of the light is split off by the beam splitter to provide reference light to track the LED performance. The rest of the light passes through a clear pressure window and enters the sample volume where it is attenuated by the natural scattering and absorption properties of the water. The remaining light passes through the receiver housing pressure window and, after final focusing, is gathered by the receiver detector.

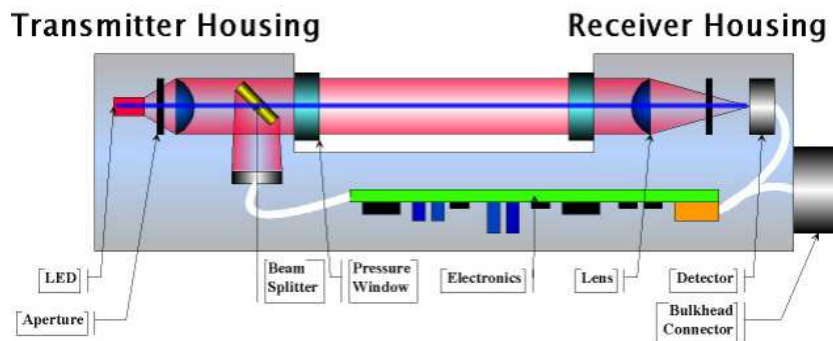

**Figure 2.** Relationship between transmitter and receiver optics

### 3.2 Electronics

C-Star uses a modulated LED light source rather than an ordinary incandescent lamp that some other transmissometers use. This increases the rejection of ambient light and stabilizes the instrument. The C-Star Electrical Block Diagram is shown in Figure 3. A high efficiency switching power supply is used to convert the input power supply voltage to positive and negative supply voltages for the analog circuitry.

A 32 KHz crystal is used as the source for the system clock. This is divided down to 1 KHz to create the main system clock. The LED is modulated at 1 KHz to create an optical chopping frequency of 1 KHz. This modulation technique improves the rejection of ambient light (such as sunlight, 50-Hz light, and 60-Hz light), and also reduces the long-term drift of the instrument.

The LED light output is monitored using a reference detector photodiode. The output of the reference detector is amplified, and fed back into the LED driver circuit. This feedback loop greatly stabilizes the LED light output from several effects, such as changes of instrument temperature and changes in LED light output due to LED aging. The modulated LED light passes through the external sample volume (the flow tube). The resulting modulated light is received by the C detector photodiode. This signal is amplified, and then demodulated. The resulting signal passes through a DC Gain Adjust circuit, and a DC Offset Adjust circuit.

These two circuits are adjusted during calibration at the factory. The resulting output signal is the Analog Out signal.

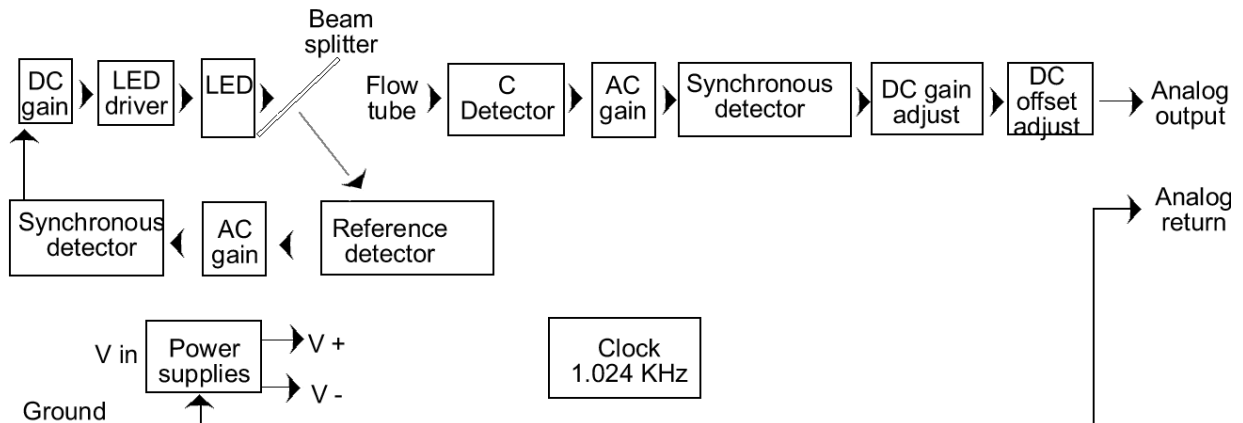

**Figure 3.** Block diagram of C-Star's main electronic components

### 3.2.1 Pin Description

The analog C-Star uses a six-pin bulkhead connector. The pinout for this connector is shown in section 4.1. Note that the pinout is compatible with the WET Labs ECO meters, and the same optional test cable can be used for either instrument.

Input power is applied on the 7–15 VDC power input wire. The power supply current returns through the common ground signal. The input power signal has a bi-directional filter. This prevents external power supply noise from entering into C-Star, and also prevents internally generated C-Star noise from coupling out on to the external power supply wire.

The output voltage is measured between the Analog Out signal and the Ground. The Analog Out signal is at full scale (5 volts nominal for analog instruments and 4095 counts for digital instruments) when the light beam is clear and the transmittance is 1. The Analog Out voltage decreases linearly with decreased transmittance. When the light beam is completely blocked and the transmittance is zero, the Analog Out voltage is 0 volts nominal (0 counts for digital instruments).

Note that the power supply ground signal is internally connected to the Analog Return signal. There is only one ground internal to the C-Star instrument. The C-Star mechanical case is floating, and is not connected to the internal C-Star power supply ground or Analog Return signal.

### 3.2.2 Analog Output Circuitry

The equivalent analog output circuitry is shown in Figure 4. The C detector photodiode signal is amplified, using analog gain circuitry. The resulting signal is then connected to a single pole, low pass filter, with an equivalent RC time constant of 0.167 sec. The reciprocal of this time constant produces the instrument data sample rate of 6 Hz. Note that the low-pass filter roll-off is 20 dB per decade of increased frequency.

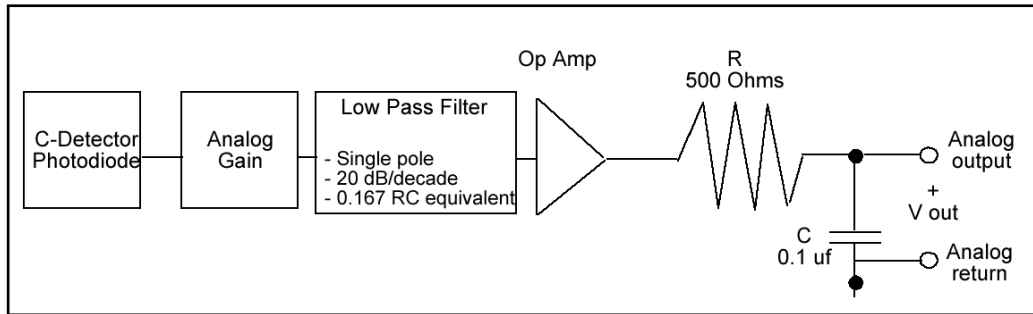

**Figure 4.** C-Star equivalent analog output circuitry

The output of the 6 Hz low pass filter is then buffered by an Op Amp. The output of the Op Amp has 500 ohms in series with the Analog Out signal. When the Op Amp output voltage is 5 volts, the series resistor limits the worst case output current to 10 mA.

The Analog Out signal has a 0.1 $\mu$ F ceramic capacitor connected to the Analog Return signal. The 500-ohm resistor and the 0.1 $\mu$ F capacitor create a low pass filter with a time constant of 50  $\mu$ sec, or 20KHz. This circuit reduces any high frequency noise on the Analog Out signal.

The Analog Out signal should be connected to a circuit with a high input impedance. If the Analog Out signal is connected to a circuit with a low input impedance, the voltage on the Analog Out signal will be reduced by the voltage divider created by the 500 ohm output series resistor, and the low input impedance of the connecting circuit.

If the input impedance is less than 100K ohms, an Op Amp voltage follower should be inserted, to create a circuit with a high input impedance. Typically, an analog-to-digital (A/D) converter is used to sample the Analog Out signal. The input impedance of A/D converters can be as low as 1K ohm, which is too low for the Analog Out signal. Use a voltage follower Op Amp between the Analog Out signal and the A/D converter input, to buffer the mismatch between the output and the input impedance of the two circuits.

### 3.2.3 Power Dissipation

The C-Star power supply uses a high efficiency switching power supply to reduce power dissipation. Figure 5 shows the input voltage versus input current, and Figure 6 shows the input voltage versus input power dissipation for a typical C-Star. The graphs include the curves for cleared beam output (when Analog Out = 5 volts nominally) and for blocked beam output (when Analog Out = 0 volts nominally).

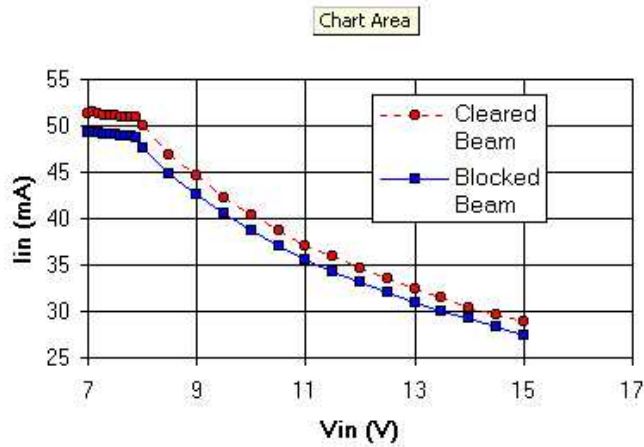

**Figure 5.** C-Star current consumption

Note that worst-case power dissipation occurs at the maximum input voltage of 15 V, and the lowest power dissipation occurs at the minimum input voltage of 7 V. This is preferable for battery-powered applications, when the C-Star power dissipation is reduced as the battery becomes discharged and the input battery voltage is reduced. The voltage and current discharge characteristics of the battery can be used with the C-Star power dissipation graph, to estimate the usable lifetime of a battery-powered C-Star system.

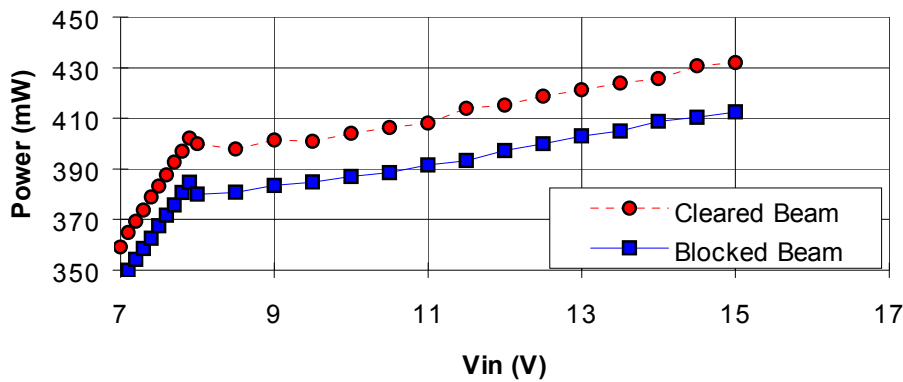

**Figure 6.** C-Star Power Dissipation



### 3.2.4 Input Power Over-voltage Protection

Figure 7 shows the input voltage and input current relationship over an extended input voltage range.

#### WARNING!

**Do not exceed the maximum input voltage specification of 15 volts in a typical application.**

---

This data is provided only to help diagnose system configuration problems.

The C-Star input voltage range is specified with a minimum of 7 V and a maximum of 15 V. In this range, the change in the ratio of input voltage to input current is approximately -335 ohms (the input current decreases as the input voltage increases).

The C-Star power supply has an input over-voltage protection circuit to avoid input over-voltage failures. This circuit activates when the input voltage is above the maximum input voltage specification of 15 V. As shown in Figure 7, the input current, and hence the input power dissipation, increase rapidly when the input voltage is above 15 V. In this range, the ratio of input voltage to input current is approximately +12 ohms (the input current increases as the input voltage increases).

It is assumed that the power supply connected to the C-Star input power signal has a finite source-impedance. As the C-Star input current increases dramatically when the input voltage exceeds 15 volts, the source impedance of the power supply will cause the power supply output voltage to be reduced.

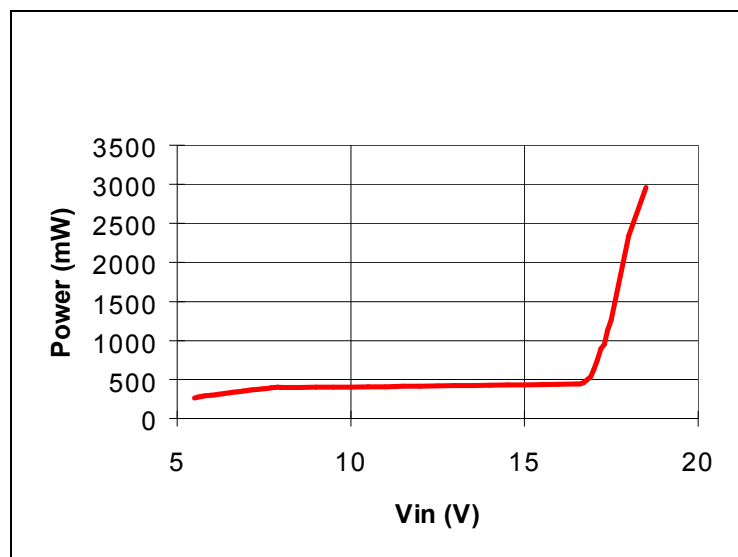

Figure 7. Relationship between input voltage and current

An equilibrium point will be reached between the power supply and the C-Star. The intention of this scenario is that the over-voltage protection circuit will draw enough current to limit the power supply output voltage, and thus eliminate C-Star hardware failures due to input over-voltage.

### 3.2.5 Input Voltage Reversal

The C-Star power supply is protected from reversed input power and ground conditions caused by errors in system level cables and wiring. A series diode protects the C-Star power supply from the reversal of input voltage polarity. As long as the reversed voltage is less than 30 V, the C-Star power supply will not be damaged. After the system wiring has been corrected, the C-Star power supply will then operate properly.

### 3.2.6 Warm-Up Time

The warm-up time for the instrument is determined by the internal electrical time constants, and the time for the analog-integrated circuits to stabilize in temperature (due to the increase in die temperature caused by their own power dissipation). A characterization of the warm up time for the instrument is shown in Figure 8. This shows the clear beam Analog Out voltage, as expressed as a ratio of its final value, versus the time since power was applied to the instrument.

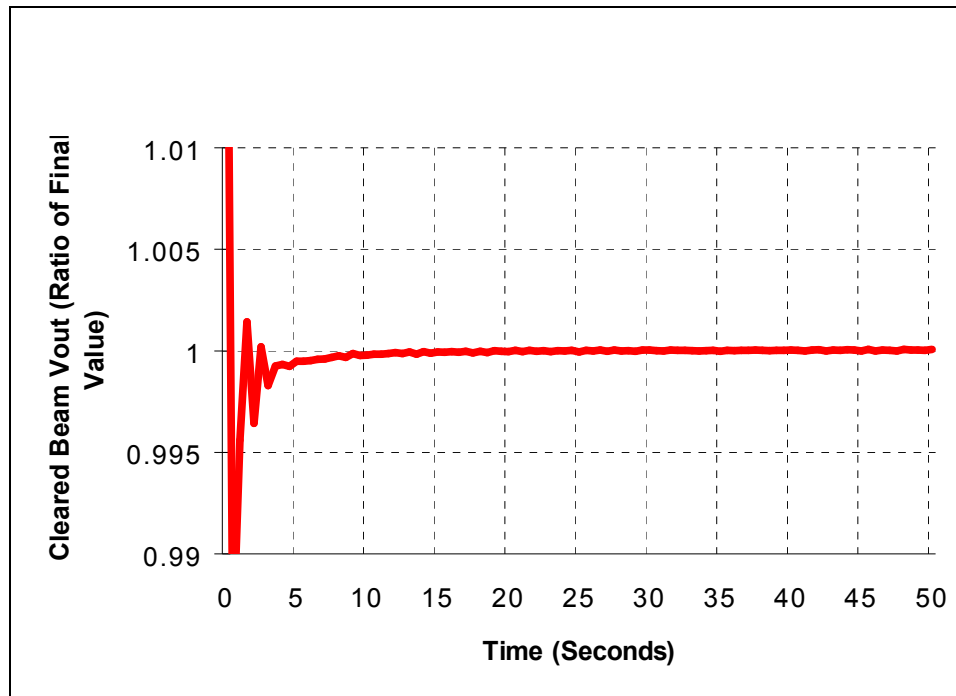

Figure 8. Red LED warm-up time

Specific applications should perform this characterization, to determine the effects of the warm up time in each unique system. To perform this characterization, the instrument should be at a stable temperature, and unpowered for at least fifteen minutes. This can be performed with air in the flow tube, and the beam cleared for full scale output voltage. Begin sampling the Analog Out signal. Then apply power to the instrument, and record the warm up time for the system.

---

### 3.3 Mechanical Components

C-Star is housed in a robust pressure vessel made from either acetal copolymer (600 m depth rating) or hard anodized aluminum (6,000 m depth rating). One of the main advantages of C-Star is its compact size. The instrument is “C” shaped, with the electronics housed in the backbone of the meter. The transmitter housing (the end opposite the bulkhead connector), contains the lamp, filter and reference feedback optics. The receiver housing holds the receiver optics and provides the mount and feed through for the bulkhead connector.

#### **WARNING!**

If the pressure housing is opened for any reason, your warranty will be voided. Additionally, the C-Star **must** be re-pressure tested prior to using in the field. We cannot be responsible for leakage that occurs after the instrument has been opened by the user.

---



## 4. Specifications

### Mechanical

Pressure housing:

25 cm pathlength—9.3 x 6.4 x 47 cm

10 cm pathlength—9.3 x 6.4 x 29.2 cm

Overall length:

25 cm pathlength (including bulkhead connector)—49 cm

10 cm pathlength (including bulkhead connector)—32 cm

Weight in air:

25 cm pathlength—2.2 kg (copolymer); 3.6 kg (aluminum)

10 cm pathlength—1.8 kg (copolymer only)

Weight in water:

25 cm pathlength—0.9 kg (copolymer), 2.7 kg (aluminum)

10 cm pathlength—0.5 kg (copolymer only)

Rated depth: 600 or 6000 m (25 cm only)

Operating range: 0–30 deg C

### Electrical

Response time: 0.167 sec (6 Hz)

Power input: 7–15 VDC

Data output: 0–5 V (analog)

0–4095 counts (digital)

Power dissipation: 400 mW (typical)

Temperature error: 0.02 percent F.S./deg C

### Optical

Sensitivity: 1.25 mV

Pathlength: 10 or 25 cm

Beam divergence: 0.8 deg in water

Wavelength: 660, 530, 470, or 370 nm

Bandwidth: ~ 20 nm

*Specifications are subject to change without notice*

## 4.1 Connectors

The standard bulkhead connector for C-Stars is a 6-pin bulkhead connector. This replaces the previous standard 4-socket connector.

Pinout summary for MCBH-6-MP C-Star connectors

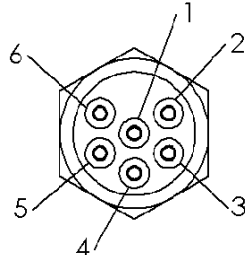
Pin	Function	MCBH-6-MP Connector diagram
1	Ground	
2	Reserved	
3	Reserved	
4	V +	
5	Optional RS-232 (TX)	
6	Analog out	

### 4.1.1 Optional Adapter Cable

An adapter cable can be purchased to connect a 6-pin C-Star to existing cabling. Note that if your application requires this adapter, it should be used as a cable extension. Disconnect **ONLY** at the 6-socket end, as it is a more robust connector.

Optional adapter cable pinout summary for four-socket C-Star connectors

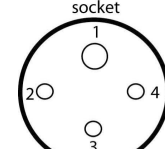
Analog		Connector diagram	Digital	
Socket	Function		Socket	Function
1	Ground		1	Ground
2	Analog out		2	Analog out
3	V+		3	V+
4	Analog return	4	RS-232 (TX)	

## 4.2 Digital Output

The RS-232 output from the digital C-Star is a single column of numbers whose values range between 0 and 4095 counts. Note that the RS-232 output is limited to a cable length of 15 feet.

### 4.2.1 Serial Port Configuration

Data Rate	Data type
9600 baud	8 data bits, 1 stop bit, no parity, no flow control

## 5. Characterization

Prior to shipment, each C-Star is characterized to ensure that it meets the instrument's specifications. WET Labs characterization procedure is described below.

### 5.1 Measurement Apparatus

To measure the C-Star output voltages for tuning and characterization, the transmissometer is connected to a 12-bit A/D converter. The A/D outputs the voltages in a standard RS-232 serial text format that is collected with a terminal program. A spreadsheet is then used to perform calculations on the collected values.

### 5.2 Procedure

There are two main steps in the tuning and testing of the C-Star. Calibration is performed before the unit is put in its enclosure. Final Testing is done with the unit completely assembled.

#### Pure Water Reference

Clean, de-ionized water is used to set the “ $V_{ref}$ ” voltage of the C-Star. This reference voltage is obtained by immersing the C-Star in clean water and measuring the average output voltage over 30–45 seconds. This voltage is provided as the  $V_{ref}$  parameter on the calibration sheet.

#### Response Time (Time Constant)

The specified time constant for the C-Star is 0.167 seconds. This time constant is the RC value, computed by  $1/RC$ . A nominally full scale output is obtained after six time constants.

To verify the time constant, the step response is observed on an oscilloscope. A nearly full scale reading is produced by measuring the output with the beam unblocked in air. The beam is then quickly blocked, and the decay is observed on the oscilloscope. The output voltage should decrease by 67 percent of the original within 0.167 seconds. When going from a blocked beam to clear, the output voltage should attain 67 percent of its final voltage within one time constant.

#### Pressure

To ensure the integrity of the housing and seals, each C-Star is subjected to a wet hyperbaric test. The testing chamber applies a water pressure of at least 50 psi. C-Stars are spot checked to the full rated depth.

#### Mechanical Stability

The C-Star is subjected to a mechanical stability test. This involves subjecting the unit to mild vibration and shock. The air, water, and dark voltages must remain the same before and after the mechanical stability test.

## **Temperature Stability**

To verify temperature stability, the C-Star is immersed in water with a beginning temperature of approximately 30 deg C, to an ending temperature of 1 deg C. A voltage sample is collected every 30 seconds, with a 0.5 second smoothing. The starting (30 deg) voltage is noted, and the ending (1 deg) voltage is also noted.

## **Electronic Stability**

This value is computed by collecting a sample once per minute for twelve hours, or more. The smoothing time for this one sample is 0.5 seconds. After the data is collected, the minimum and maximum values are determined, and the difference between these two is divided by the number of hours the test has run. The result is the stability value listed on the calibration sheet.

## **Noise**

Noise is computed from a standard deviation over 60 samples. These samples are collected at one-second intervals for one minute. The smoothing (averaging) time for these samples is 0.5 seconds. A standard deviation is then performed on the 60 samples, and the result is the published noise on the calibration form. The calculated noise must be below 1.25 mV.

## **Final Water Blank Test**

Clean, de-ionized, pure water is introduced into the sample volume. The output voltage should be between 4.5–4.7 V.

## **Voltage and Current Range Verification**

To verify that the C-Star operates over the entire specified voltage range (7–15 V), a voltage-sweep test is performed. The C-Star is operated over the entire voltage range, and the current and operation is observed. The total power consumption (voltage times current) must remain below 450 mW over the entire voltage range.

## **Linearity**

A full scale linearity test is randomly performed on C-Stars to confirm linearity. This consists of using a multiple point suspended particle dilution series to characterize the response of the instrument to varying levels of turbidity. The linear regression value must be better than 0.9900.



## **6. Calibration**

Each C-Star is subjected to several tests including a temperature bath, clean water reading and blocked path to provide the calibration values required to obtain good data in the field. The calibration documentation provided with each instrument lists these values.

The clean water calibration is done using water from WET Labs calibration facility. It goes through several stages of de-ionization, UV screening and ultra filtering to remove particles, bacteria and ions. This water is used to obtain the reference value of the instrument provided on the calibration sheet.

Each meter goes through a temperature test to determine its electronic response to changes in internal temperature. The C-Star is placed in a water bath and the water temperature is varied from approximately 30–1 deg C.

The offset value is obtained by blocking the beam with the instrument clean and dry. This value is recorded and provided on the calibration sheet.

An air reading is also obtained with the instrument clean and dry. This value is used as a reference when cleaning the optics and as an aid in tracking instrument drift.

## Appendix: Dimensional Drawing

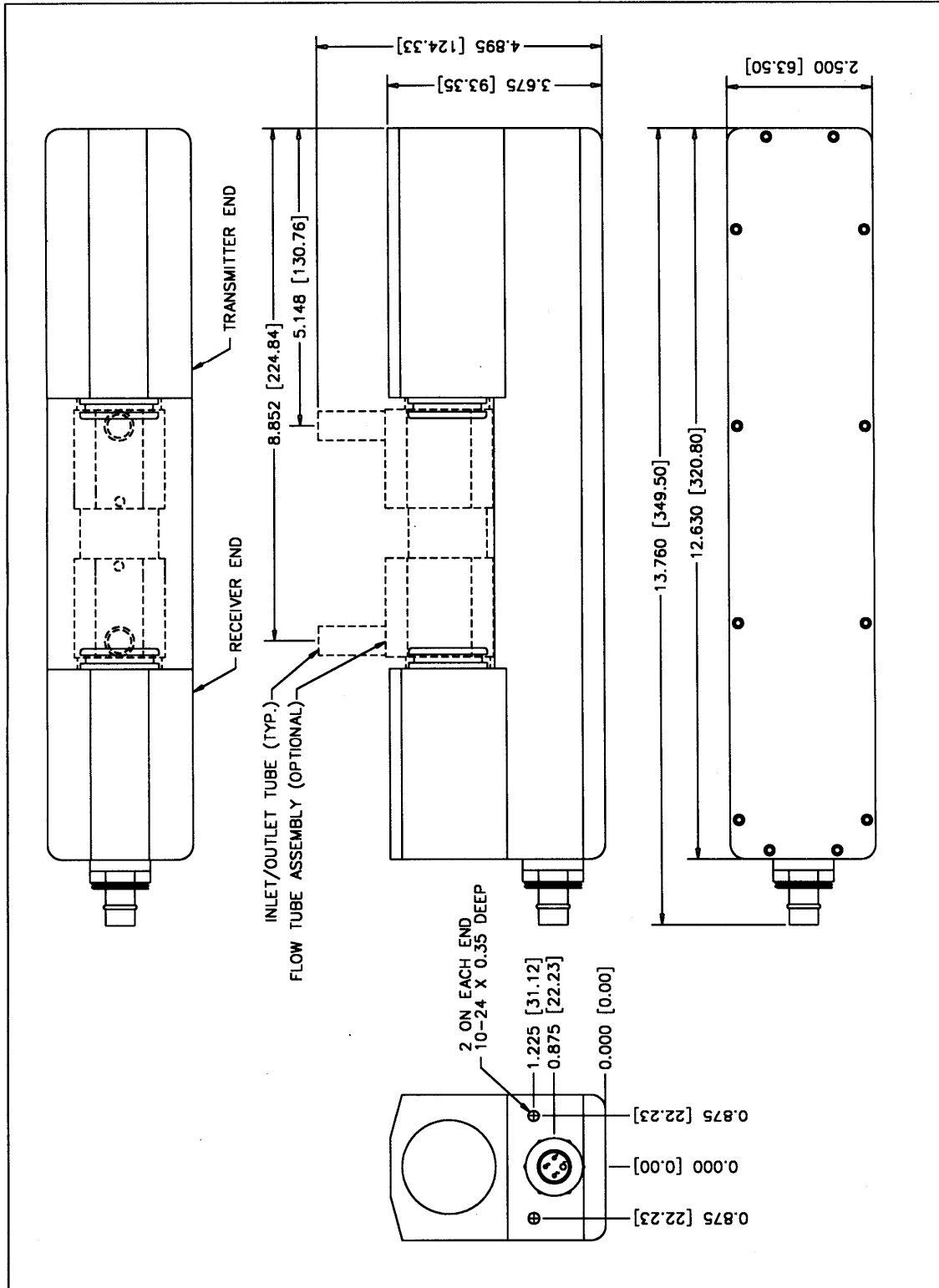

## Revision History

<b>Revision</b>	<b>Date</b>	<b>Revision Description</b>	<b>Originator</b>
A	10/07/99	Begin revision tracking	H. Van Zee
B	01/03/00	Update Theory of Operation, Instrument Operation, Data Analysis, and Specifications (DCR 5)	C. Moore
C	08/10/00	Correct beam divergence specification (DCR 9)	H. Van Zee
D	10/24/00	Misc. non-content-related corrections (DCR 67)	H. Van Zee
E	02/26/01	Update graphics, delete references to interference filter (DCR 79)	D. Hankins
F	5/30/01	Add leak-resistant flow sleeves to optional equipment; revise specifications to include 10 cm details (DCR 91)	H. Van Zee
G	11/15/01	Remove reference to 6061 aluminum (DCR 160)	A. Derr
H	12/10/01	Add specifications for digital C-Star (DCR 171)	W. Strubhar
I	01/09/02	Add test cable for digital output option (DCR 175)	D. Stahlke
J	05/29/03	Add digital specifications to section 4; delete digital test cable section (DCR 304)	H. Van Zee
K	06/23/03	Add 370 nm meter, correct green wavelength (DCR 310)	H. Van Zee
L	08/06/03	Add optional 6-pin digital connector pinouts (DCR 329)	D. Stahlke
M	1/13/06	Clarify warranty statement (DCR 481)	A. Gellatly, S. Proctor
N	1/19/06	Delete temperature correction Appendix (DCR 482)	H. Van Zee
O	4/24/06	Delete linearity error spec (DCR 496)	H. Van Zee
P	3/31/08	Replace 4-contact VMG with 6-pin MCBH connector as new standard (ECN 286, DCR 566)	M. Johnson, H. Van Zee
Q	12/16/08	Correct typo on p. 8 (DCR 642)	H. Van Zee