



VCC-HD4600/HD4600P

Chapter 1

Introduction

Features of This Camera
Specifications
Target size and recording time
Name and Function of Each Component
Connections
Settings with the Menu Screen

Features of This Camera

Support of Network Operation

The camera supports network operation. By simply connecting a LAN cable to it, you can construct the most advanced network monitoring system. From the Web browser (Internet Explorer) installed on your PC, you can operate the camera via the network in an easy-to-use manner.

The camera supports bidirectional audio communications, enabling you to communicate with people at the camera from your PC while monitoring the surveillance video, instead of just hearing sounds from the camera.

In addition, it is a PoE product that can be powered through a LAN cable, so you can install it in locations where there is no power outlet nearby.

High-Resolution and High-Quality Images

The camera has 4-megapixel CMOS sensor that produces clear images at ultra-high resolution.

When connected to a high-definition monitor, the camera allows you to monitor the video in the full high-definition format.

Using multi-stream video transmission, it can simultaneously deliver up to four video/image streams. Because it allows video/image compression format, resolution, and other image conditions to be set as desired for each stream, you can choose the optimal video/image for your application.

Equipped with a Variety of Functions

With a 10× built-in optical zoom lens, the camera offers a zoom magnification of up to 160× in conjunction with the electronic zoom function.

The digital PTZ function lets you clip specific areas of the subject in VGA size and perform pan, tilt, and zoom operations just as when using a PTZ camera.

The camera's motion sensor function can work in conjunction with any external alarm device, facilitating the construction of a high-level security system.

A commercially available SD memory card or an external hard disk drive (optional dedicated hard disk case required) can be used to record the video on the camera.

Highly Scalable Design

Installing associated software applications on your PC further extends the capabilities of your surveillance system.

Specifications

Camera

Image pickup device	1/2.5" CMOS sensor
Effective pixels	16:9 1920 (H) × 1080 (V), 4:3 2288 (H) × 1712 (V)
Lowest image illumination	50IRE: 2.0 lx (F1.8, in color mode with high gain) 50IRE: 0.1 lx (F1.8 in black-and-white mode with high gain)
Video S/N ratio	50 dB or higher (when AGC is 'OFF')
Lens	Focal Length: f=6.3 - 63 mm F number: F1.8 - 2.5 Optical zoom 10x, electronic zoom 16x (up to 160x when used in combination with the optical zoom)
Day/Night function	Auto, color, black-and-white, alarm input switching
Focus	AUTO, MANUAL, ONE PUSH
White balance	Auto (ATW), one push (AWC), manual (R/B gain adjustable), indoor, outdoor, fluorescent
Backlight compensation	Multi-spot evaluative metering, center-weighted evaluative metering, masking, face detection
Electronic sensitivity boosting	Auto (32x max) or Off
Electronic shutter	VCC-HD4600P: 1/25, 1/50, 1/120, 1/250, 1/500, 1/1000, 1/2000, 1/4000, 1/10000 VCC-HD4600: 1/30, 1/60, 1/100, 1/250, 1/500, 1/1000, 1/2000, 1/4000, 1/10000 Long exposure shutter (1x, 2x, 4x, 8x, 16x, 32x)
Iris	AUTO/MANUAL (electronic iris: ON/OFF)
Digital PTZ	Enables electronic pan, tilt, and zoom operations on clipped subject areas in VGA size, Zoom magnification: 2x max
Camera settings	Up to 2 patterns of monitoring conditions are configurable.
AGC gain	Normal/Middle/High (Manual gain setting possible at Off)
Gamma correction	0.45, 1, Mode 1, Mode 2
Aperture compensation	On/Off (Correction level adjustable)
VIVID COLOR EFFECT	ON/OFF
DNR (digital noise reduction)	ON/OFF
Image inversion	Horizontal/Vertical/Horizontal and vertical/Off
Privacy mask	On/Off, max. 8 mask patterns
Motion sensor	On (Motion masking/motion detection area setting, or video analytics)/Off, face detection
Sway compensation	ON/OFF
Language selection	English, French, German, Spanish, Japanese

I/O

Video output	HD Output: HDMI terminal (TYPE C) Monitor output for video adjustment: BNC terminal (MONITOR OUT)
LAN	10BASE-T/100BASE-TX (RJ-45 connector)
EX-HDD Connector	For external hard disk case connection
SD Card Slot	1 (SDHC compliant, max. 32 GB supported)
Alarm input	2 (NO/NC), also serving as Day/Night switching function input <control terminals>
Alarm output	2 (NO/NC switching, 16 V, 150 mA, open collector) <control terminal>
Lens remote control	Zoom, Focus, Common (Voltage control: $\pm(6$ to 12 V)) <control terminal>
Audio input/output	Audio input (3.5-mm Mini jack) <AUDIO IN> Audio output (3.5-mm Mini jack) <AUDIO OUT>

Recording media

SD memory card	Normal recording, Alarm recording, Backup recording in event of a network failure, Log information recording
External HDD	Normal recording, Alarm recording, Backup recording in event of a network failure, Log information recording

Network

Image/video compression	H.264/JPEG
Video size (H.264)	(16:9) 1920×1080, 1280×720, 640×360, 320×180 (4:3) 1600×1200, 1280×960, 1024×768, 640×480, 320×240
Video size (JPEG)	(16:9)1920×1080, 1280×720, 1024×576, 640×360 (4:3) 2288×1712, 1600×1200, 1280×960, 1024×768, 800×600, 640×480, 320×240
Picture quality	QUALITY mode: BASIC, NORMAL, ENHANCED, FINE, SUPER FINE BITRATE mode: User-specified bit rate
Interface	10BASE-T/100BASE-TX
Protocol	TCP/IP, UDP, HTTP, HTTPS, SMTP, NTP, DHCP, FTP, DDNS, RTP, RTSP, RTCP
Audio	G.711 (Bidirectional)
Simultaneous access	20
Security	BASIC authentication (ID/password), SSL, IP filtering

Others

Operating ambient temperature/humidity	-10 to +50°C/14 to 122°F 90% RH or less (no condensation)
Power source	12 to 15 VDC 24 VAC±10%, 50/60 Hz PoE
Power consumption	15 W (PoE: 12.3 W)
Weight	420 g/14.8 oz.
Dimensions	

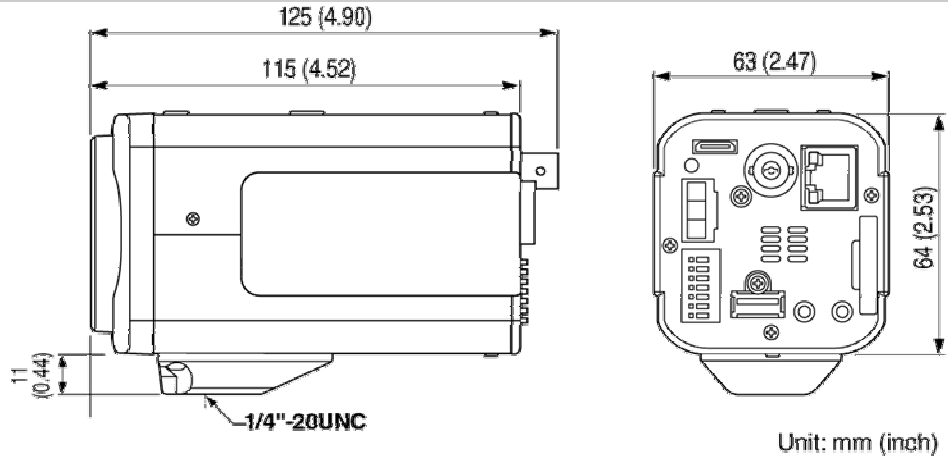

Accessories

- 1 Power supply connector
- 2 CD-ROM



Appearance and specifications are subject to change without prior notice or obligations.

Target size and recording time

Target size by resolution



This table is displayed using a browser-specific function and therefore not displayed on the PDF manual.

Refer to the table "Target size and recording time" in the electronic manual.

Recording time by resolution



This table is displayed using a browser-specific function and therefore not displayed on the PDF manual.

Refer to the table "Target size and recording time" in the electronic manual.

Name and Function of Each Component

Rear Face

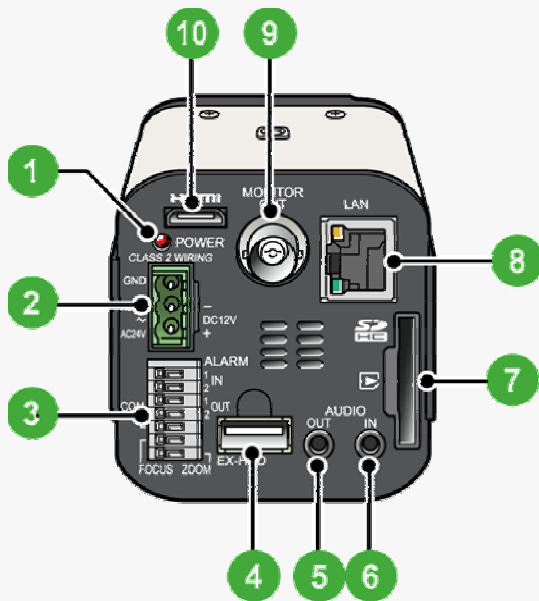

1 Power Indicator (POWER)

This indicator lights up when the camera is powered on.



When the camera is on, this indicator blinks to indicate the following camera statuses:

- Firmware update in progress
- Deactivation of media recording is in progress.
- Error occurring on SD memory card or external hard disk drive (faster blink)

2 24 VAC/ 12 VDC Power Terminal

Connect a 24 VAC or 12 VDC power supply to this terminal using the supplied Power supply connector. For details, refer to the “Basic Connections” section.

3 Control Terminals (7 push-lock pins)

For the detailed connection procedure, refer to the “Control Terminal Connections” section.

1 Alarm input or Day/Night switching terminals (ALARM IN1/2)

These input terminals can be used for either of the following purposes:

Alarm input

Connecting an external switch, infrared sensor, or other device to these terminals enables the camera to detect alarm conditions such as the entry of an intruder.

Day/Night switching

Normally, switching the camera between the color and black-and-white video modes is automatically accomplished by the Day/Night function.

Using one of these alarm input terminals as the Day/Night switching terminal, however, enables the camera to be switched between the color and black-and-white video modes when an external control signal is received.

2 Alarm output terminals (ALARM OUT1/2)

Connect a buzzer, lamp, or other alarm device to these terminals.

3 Zoom/Focus adjustment terminal (ZOOM/FOCUS)

Zoom and focus adjustment operations can be performed remotely by external voltage control.

4 COM terminal (GND)

4 External hard disk terminal (EX-HDD)

To record live video on a hard disk, put the hard disk in a dedicated hard disk case (VA-HDC4000) (sold separately) and then connect the case to the camera.

For details, refer to “Formatting the recording media”.

5 Audio Output Jack (AUDIO OUT, 3.5-mm mini jack)

Connect this jack via an audio cable to the audio input jack of an amplified speaker system or the monitor.

6 Audio Input Jack (AUDIO IN, 3.5-mm mini jack)

Use this jack to connect an external microphone to listen to the sound while monitoring the live video, or simultaneously record the video and sound.



This jack supports 3.5-mm diameter monaural microphone plugs, or monaural line-level input plugs (the left channel only for stereo plugs).

7 SD (SDHC) Card Slot

When recording live video onto an SD memory card, insert the card into the slot.

For details, refer to “Formatting the recording media”.

8 LAN Connector (RJ-45)

Use this socket to connect the camera to your PC to enable network operation.

For details, refer to the “Basic Connections” section.



Link access indicator (Green):

This indicator lights up approx. 3 seconds after power on, if a connection has been established between the camera and the network.

After that, it will blink when data are being transmitted via the network.

Speed indicator (Orange)

The camera automatically detects the local network transmission speed (10BASE-T or 100BASE-TX).

This indicator lights up when 100BASE-TX data transmission is in progress; it goes out when 10BASE-T data transmission is in progress.

9 Monitor output terminal for video adjustment (MONITOR OUT: BNC type)

Connect this terminal to a monitor, etc. A live video will be displayed on the monitor once the camera is turned on.

For details, refer to the “Basic Connections” section.



While displaying live video, the current zoom magnification is displayed on the screen.

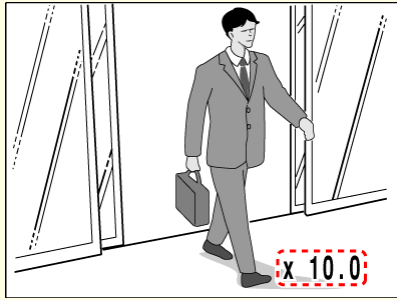

<Zoom magnification display>

Optical zoom area: $\times 1.0$ to $\times 10.0$

Electronic zoom area: $\times 11$ to $\times 160$

Zoom magnification settings (ex. enabling/disabling the magnification display, displaying position) can be configured via network operation on the VIDEO & AUDIO SETTINGS(TV OUT) screen.

10 HD video output terminal (HDMI)

The terminal outputs super-fine HD (High Definition) video signal. Use the terminal to connect a high-definition monitor with HDMI interface.

For details, refer to the “Basic Connections” section.

Side Face

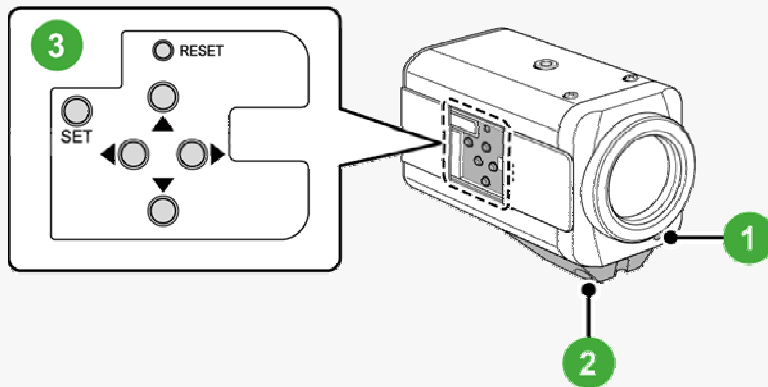

1 Power indicator

The indicator also works as an error indicator.

Power indicator: The indicator lights up when the camera is powered on.

Error indicator: The indicator blinks when an error occurs.



To activate the power or error indicator, via network operation on the OPTION SETTINGS screen, change the setting for [POWER LED (FRONT)] or [ERROR LED (FRONT)] respectively.

2 Bracket

This bracket may be attached to either the top or bottom face of the camera depending on the installation environment.

For bracket installation, be sure to use the longer screws supplied.

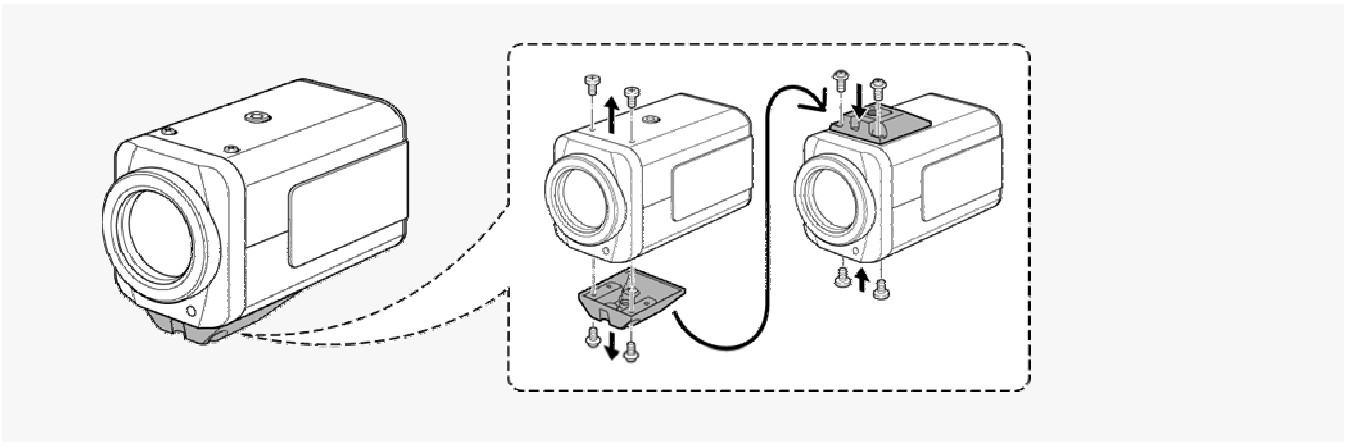

Install the camera securely to a durable location, taking into account the total weight of the camera mount (commercially available) and the camera.

3 Operation Buttons

When using operation buttons on the camera, slide and open the side cover to access the buttons.



Some operations can be performed via network operation.

A Basic operations (focus adjustment, zoom, etc.)

Operation	Associated button and use	Equivalent network operation screen
Adjusting focus	Press the \triangle button to set the focus to a near target; press the ∇ button to set the focus to a far target.	Live screen control panel
ZOOM	Press the \triangleleft button to zoom out of the image; press the \triangleright button to zoom into the image.	Live screen control panel







B Menu screen operations

Press the SET button for 2 seconds or more to display the menu screen.

For details, refer to the "Settings with the Menu Screen".

Operation	Associated button and use
Moving the cursor up or down	Press \triangle button to move the cursor upward, or press ∇ button to move the cursor downward.
Selecting the setting value	Press \triangleleft or \triangleright button to change the setting value.
Set the selected value	Press the SET button.

Miscellaneous operations (ex. restarting the camera)

Operation	Associated button and use	Equivalent network operation screen
Restarting camera	Press the RESET button.	OPTION SETTINGS (CAMERA REBOOT)
Restoring factory default settings	Press the  and  buttons simultaneously.	OPTION SETTINGS (FACTORY DEFAULT)
Stopping recording/Removing the recording medium	Press the  and SET buttons simultaneously. → The power indicator starts blinking and then stay lit when the camera is ready for you to remove the recording media.	SD/HDD
Resuming recording/Recognizing the recording medium	Press the  and SET buttons simultaneously. → The power indicator starts blinking and then stay lit after the camera recognizes the recording medium and is ready for recording.	SD/HDD
Resetting the login password (for default users only)	Press the  and  buttons simultaneously.	Not supported via network operation



Never press the RESET button while recording is in progress. The video may not be recorded properly.

Connections

Perform the following connections according to the installation environment and application of your camera.

Basic Connections

- A Power Connection
- B High-Definition Monitor Connection
- C Monitor connection for video adjustment
- D Network Connection

Control Terminal Connections

- A Alarm Input/Output Terminal Connections
- B Remote Zoom/Focus Adjustment Operation



Before attempting the following connections, be sure to turn off all components of your system. Improper connection may cause smoke or failures. Before attempting to connect each system component, carefully read the instruction manual that comes with it to familiarize yourself with the correct connection procedure.

Basic Connections

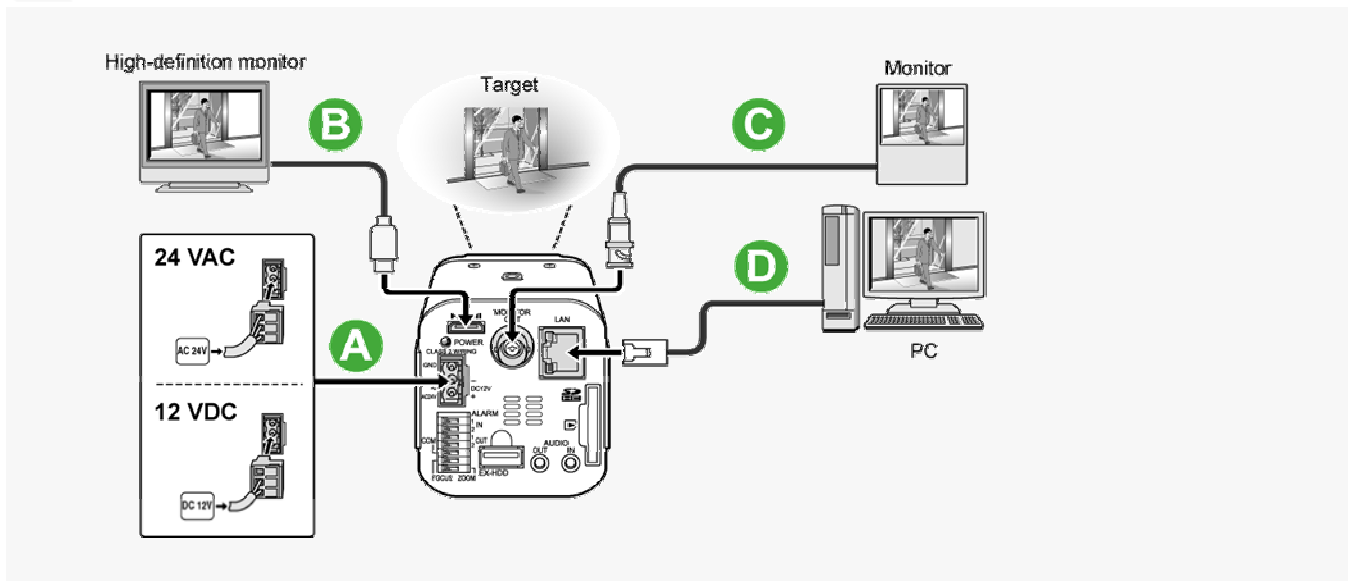

A Power Connection

Attach the supplied power connector into the power terminal.

Loosen the screws on the side face of the connector, connect the power cables to it, and tighten the screws. Connection method depends on the power supply (24 VAC or 12 VDC).

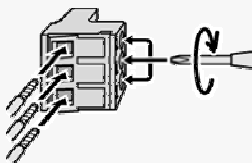

A Connection to 24 VAC power supply

Although the power terminals have no polarity, the earth grounding wire must be connected to the COM (GND) terminal.

B Connection to 12 VDC power supply

Note the polarity (+/-) of the power terminals when connecting the camera to a 12 VDC power supply. Incorrect polarity may cause damage to the camera.

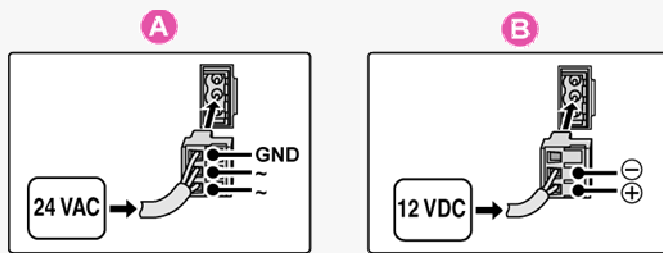

To prevent a fire hazard use any UL listed wire rated VW-1.

Be sure to use an 18AWG or thicker wire power cable.

If you must use a long power cable, determine the cable type by ensuring that the voltage at the 24-VAC/12-VDC terminal is within the operating range of the camera.

When the camera is powered on, the POWER indicator lights up and the live video is displayed on the connected monitor.

B High-Definition Monitor Connection

Connect the HDMI cable to the HD video output terminal (HDMI).



You cannot output the video simultaneously from HD video output terminal (HDMI) and from monitor output terminal (MONITOR OUT). When both terminals are used, the HD video output terminal takes precedence.

C Monitor connection for video adjustment

Connect the coaxial cable to the SD video output terminal (MONITOR OUT).

D Network Connection

This camera is designed so that you can use all of its functions via network operation.

By connecting the network (LAN) socket of the camera to your PC using a LAN cable, you can configure and operate it from the Web browser installed on your PC.

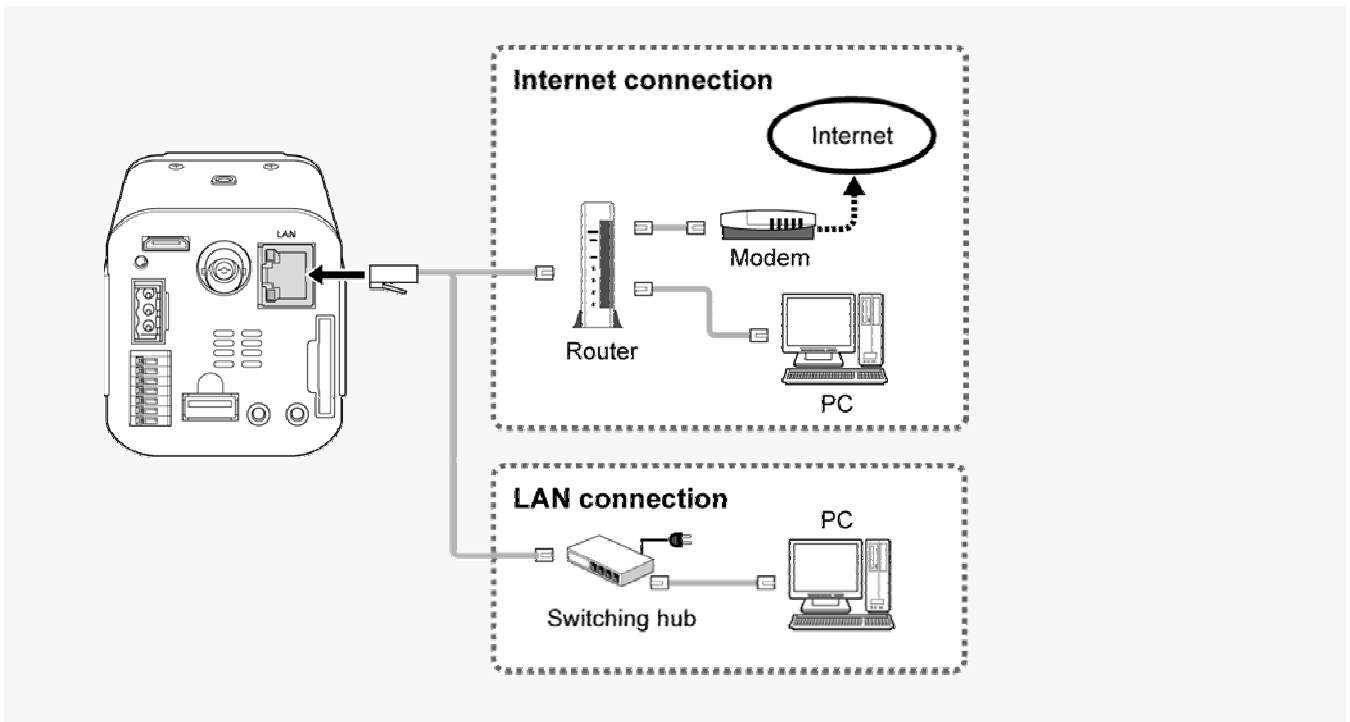

Use a LAN cable no longer than 100 m (109.4 yards) with the shield type CAT5 or higher.
The supported Web browser is Internet Explorer Ver.6.0 SP2 or higher, or Internet Explorer Ver.7.0.



Configure the network information using the camera's menu item [NETWORK SET].
For details, refer to "Configuring the network settings of the camera" section.
The same settings can be performed via network operation on the NETWORK SETTINGS screen.

About the internet connection

Port forwarding for the video port must be enabled on the broadband router.
For details on how to set port forwarding, please refer to your router's Instruction manual.

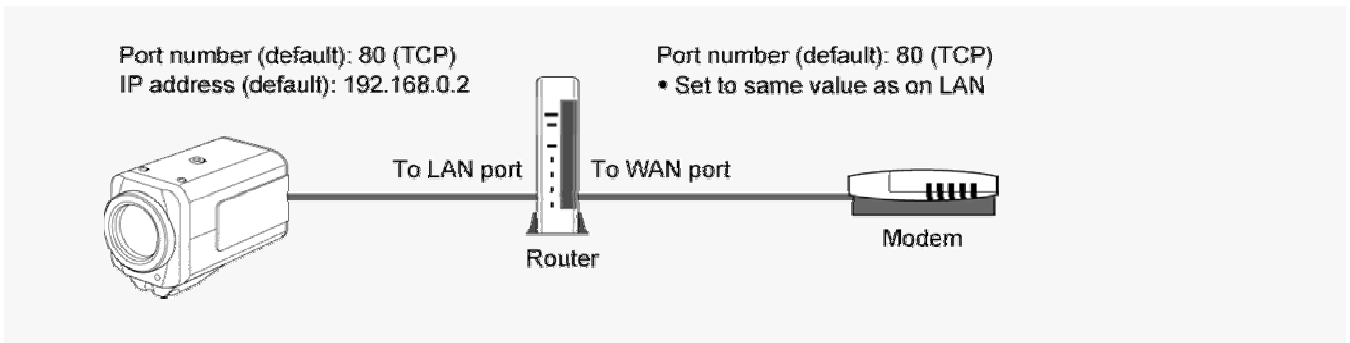

To connect two or more cameras, on the NETWORK SETTINGS screen, assign them with port numbers that are different from that of the first camera.

Using PoE

This camera supports PoE (Power over Ethernet). This means that you can install the camera in locations where there is no 24-VAC/12-VDC power outlet nearby.



When using PoE to power the camera, do not use the camera's power terminals.
Do not power the PoE hub or PoE power adapter until you finish connecting the camera.
When the PoE power supply is LAN, you cannot record video to an external hard disk drive.

A Connecting the PC and camera through a switching hub

You can use a PoE-compatible switching hub to extend the transmission distance.
For details on the extendable distance, please refer to the hub performance in the specifications, etc.

B Connecting the PC and camera through a switching hub and a power adapter

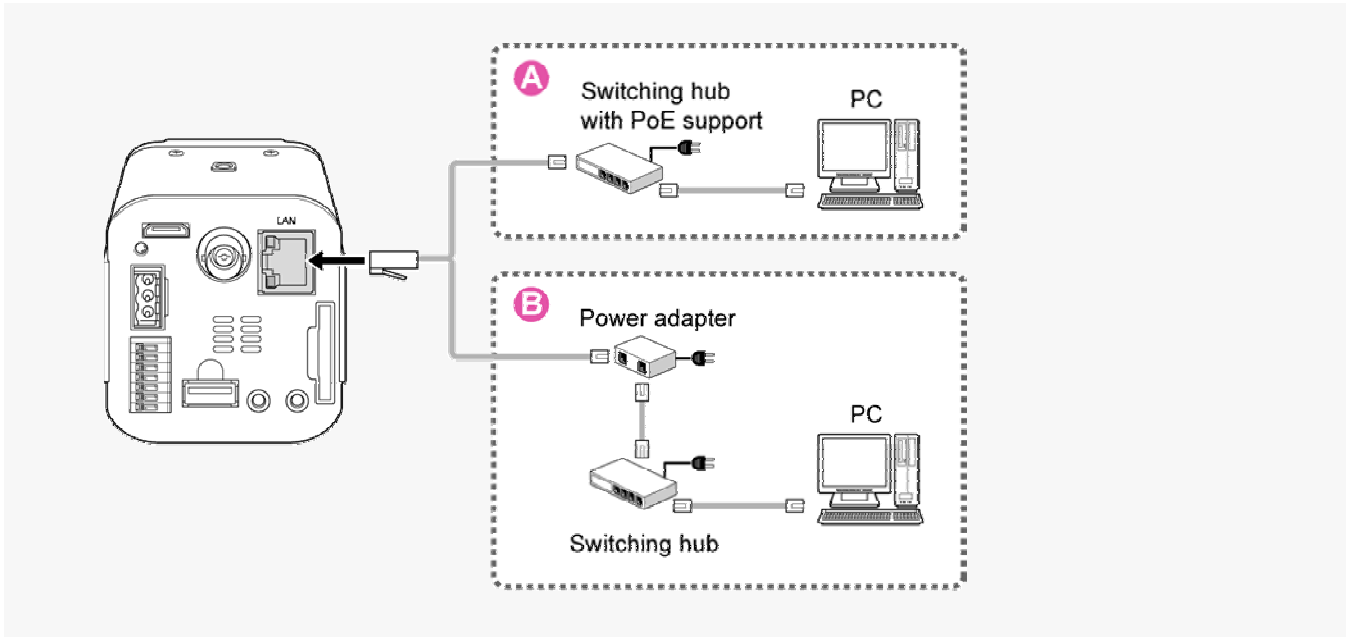

Control Terminal Connections

To connect a cable, while pushing the protrusion of the terminal, insert the cable into the opening and then release it.



Use a thicker cable than 24AWG for connection. (Maximum length 600 m)

A Alarm Input/Output Terminal Connections

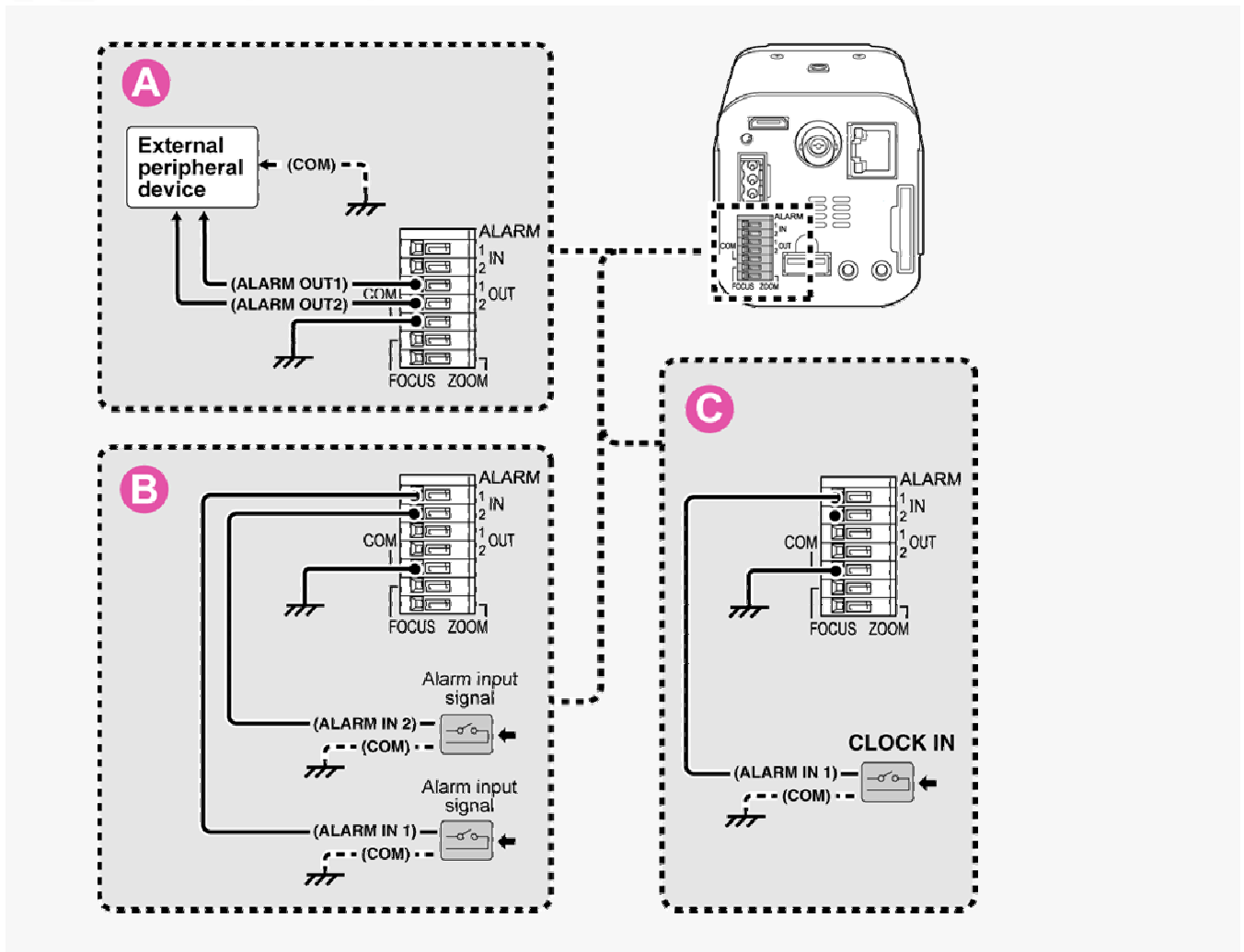

A Alarm Output Terminal Connection

Connect a buzzer, lamp, or other alarm device to one of the alarm output terminals (ALARM OUT1 or 2).



After connecting an alarm device, configure the output conditions for the corresponding alarm output terminal (ALARM OUT1 or 2) via network operation on the ALARM SETTINGS screen.



Alarm output terminal configuration is also possible via remote operation.

B Alarm Input Terminal Connection

Connect an alarm switch, infrared sensor, or other external device to one of the alarm input terminals (ALARM IN1 or 2).



After connecting an alarm device, configure the input conditions for the corresponding alarm input terminal (ALARM IN1 or 2) via network operation on the ALARM SETTINGS screen.

To use the alarm input terminals as Day/Night switching terminals, follow the steps below.

Under [DAY/NIGHT], set [DAY/NIGHT] to "COLOR" and select the terminal you want to use in [EXT ALARM].

On the ALARM SETTINGS screen, in [POLARITY], select the signal polarity of the alarm input terminal.

C Alarm Input Terminal Connection for Clock Adjustment (CLOCK IN)

You can connect an external switch to the ALARM IN1 terminal and use that switch to adjust the camera's internal clock.



To do so, via network operation, configure the [CLOCK IN] setting on the CLOCK SETTINGS screen.

B Remote Zoom/Focus Adjustment Operation

Connect control equipment for the camera to the control connector's ZOOM and FOCUS terminals.

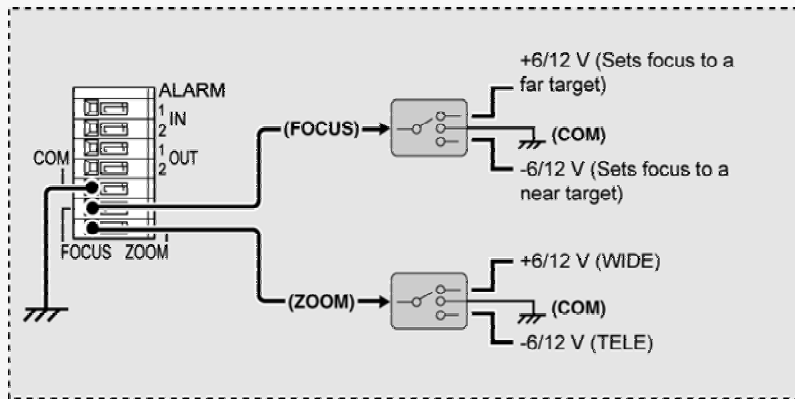

Settings with the Menu Screen

Opening the side cover and pressing the SET button for 2 seconds or more causes the menu screen to be displayed on the monitor.

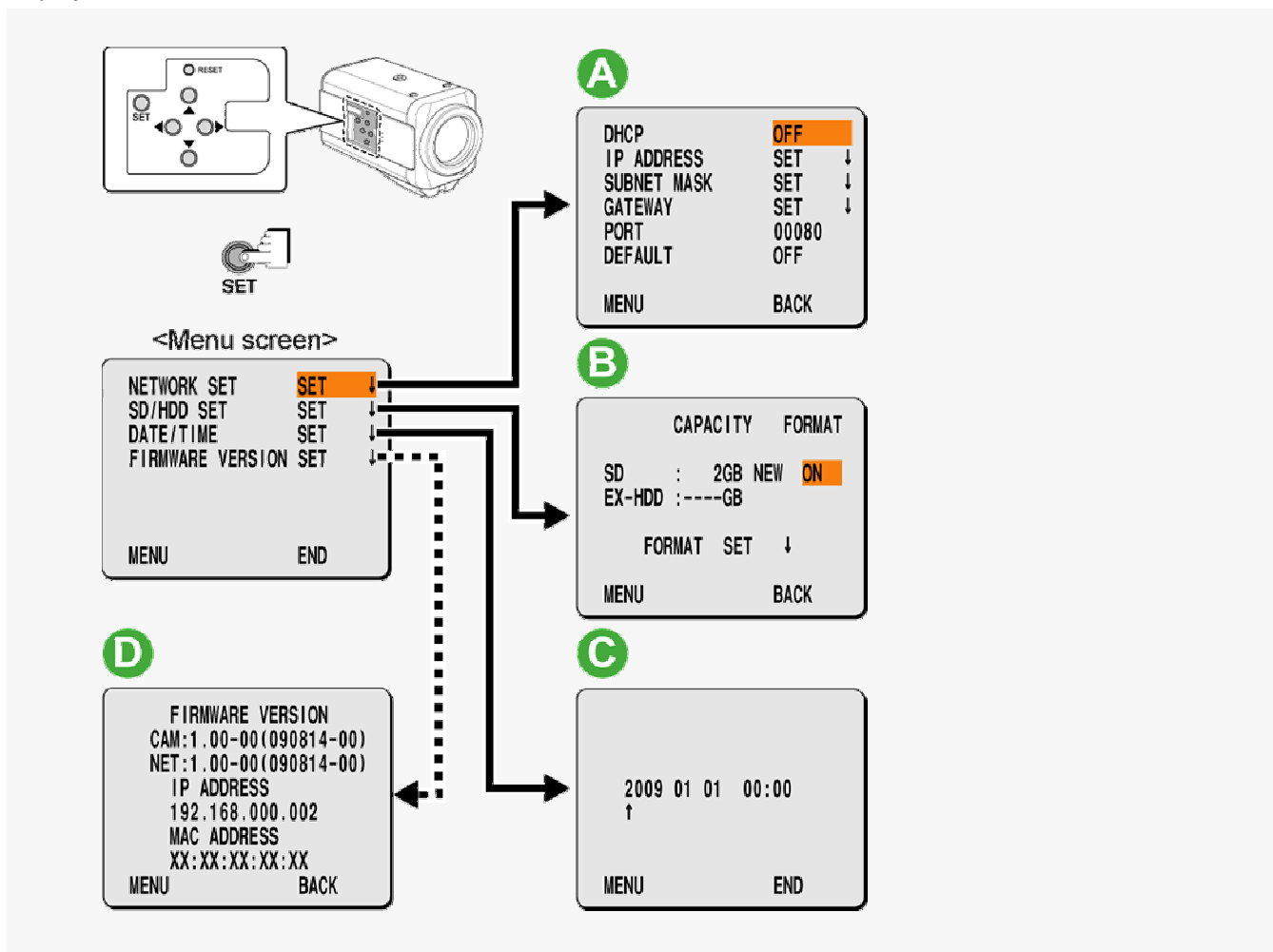

On the menu screen, all information is displayed in English.

Each setting can be configured via network operation on a configuration menu screen.

A Configuring the network settings of the camera (NETWORK SET)

If you plan to operate the camera via the network, you need to configure the network information, such as the IP address, on the camera.

You can skip this configuration if you choose to use the defaults.

<Default>

- DHCP: OFF
- IP ADDRESS: 192.168.000.002
- SUBNET MASK: 255.255.255.000
- GATEWAY: 192.168.000.001
- PORT: 80



You can change the configured network settings via the network on the NETWORK SETTINGS screen.



For the network configurations, contact your network administrator.

- 1 Use the Δ/∇ button to select [NETWORK SET] on the menu screen, and press the SET button.

The network configuration screen appears.

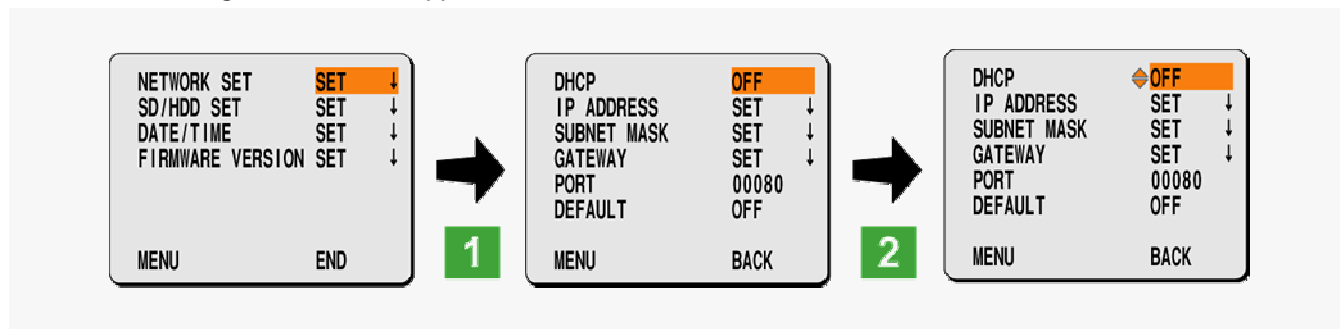

- 2 Select [DHCP] using the Δ/∇ button and press the SET button.

The \diamond symbol appears beside the available option, and you are ready to configure it.

- 3 Use the Δ/∇ button to select “ON” or “OFF” for [DHCP], and press the SET button.

The setting is saved and the \diamond symbol disappears.

- ▶ OFF: Sets the IP address manually (Go to step 4.)
- ▶ ON: Enables automatic address configuration using DHCP. (Go to step 7.)



Setting [DHCP] to “ON” causes the menu items [IP ADDRESS], [SUBNET MASK], and [GATEWAY] to disappear.

- 4 Select [IP ADDRESS] using the Δ/∇ button and press the SET button.

The IP ADDRESS screen appears.

- 5 Move the cursor to the desired position using the \leftarrow/\rightarrow button, select a number in each digit using the Δ/∇ button, and then press the SET button.

The configured address setting is saved and you return to the network configuration screen.

- 6 In the same way as you did in [IP ADDRESS] (step 4 to 5), configure the settings in [SUBNET MASK] and [GATEWAY].

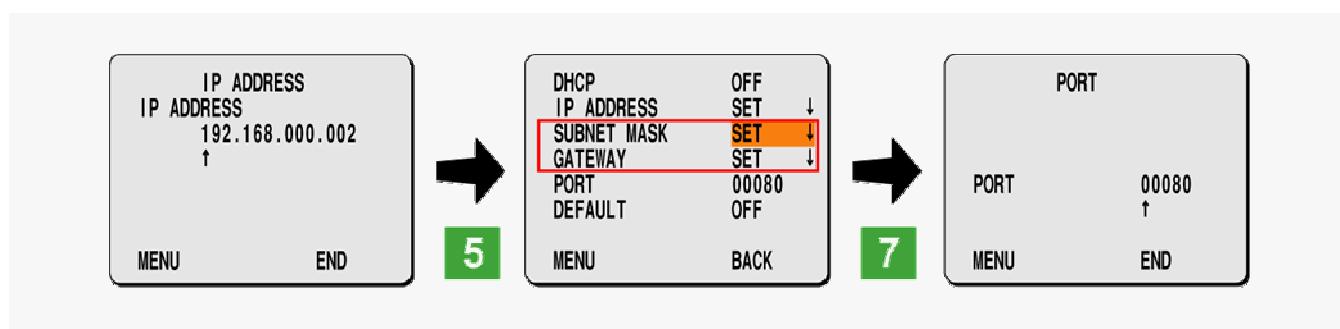

- 7 Select [PORT] using the Δ/∇ button and press the SET button.

The PORT screen appears.



When [SSL] is set to “ON” on the NETWORK SETTINGS screen, the screen title appears as [PORT (SSL)].

- 8 Move the cursor to the desired position using the \leftarrow/\rightarrow button, select a number in each digit using the Δ/∇ button, and then press the SET button.

The configured port number is saved and you return to the network configuration screen.

- 9 Use the Δ/∇ button to select [MENU] and press the SET button. After this, use the Δ/∇ button to select “END” and press the SET button.

This finishes the network settings and you return to the menu screen.

Restoring the factory default settings (DEFAULT)

To reset all the settings configured on the network configuration screen to the defaults (factory settings), follow the steps below.

- 1 Select [DEFAULT] using the Δ/∇ button and press the SET button.

The \diamond symbol appears beside “OFF”, and you are ready to select “ON” or “OFF”.

- 2 Select “ON” using the Δ/∇ button and press the SET button.

All the settings configured on the network configuration screen are reset to the defaults and the \diamond symbol disappears.

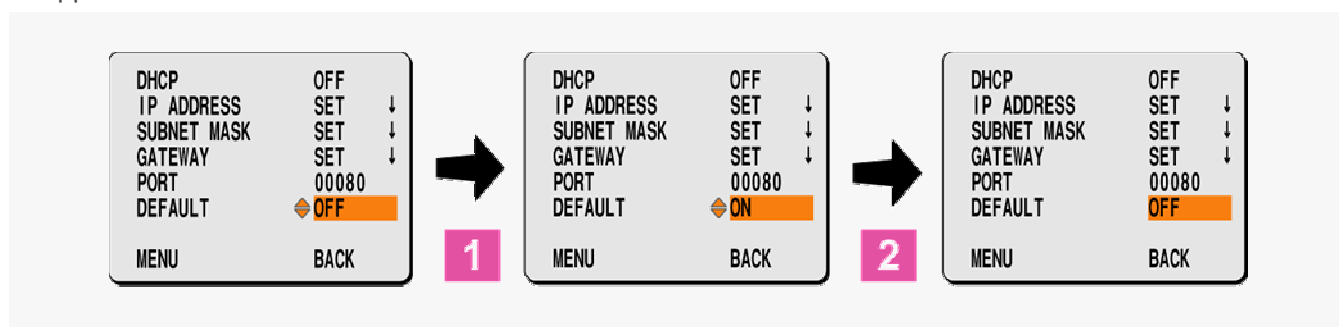

B Formatting the recording media (SD/HDD SET)

You can format the SD memory card and external hard disk installed on the camera using the SD/HDD SET menu.



Formatting the recording media can also be done via network operation on the SD/HDD screen.

When formatting a medium via network operation, you can specify the storage area capacity ratio between normal and alarm recording areas.

When formatting a medium using the menu on the camera, the default values for the SD/HDD screen (Normal recording=80, Alarm recording=20) will be applied.



Be sure to turn off the camera before installing a recording medium.

When you want to remove the recording medium, be sure to perform the following procedure in advance.

- Set [SD MEMORY CARD]/[HDD] to “NO USE” on the SD/HDD screen via network operation.
- Or press the Δ and SET buttons on the side face of the camera simultaneously.

The power indicator starts blinking and then stay lit when the camera is ready for you to remove the recording media.

Installing Recording Media

SD memory card

How to insert the SD card

Insert an SD memory card into the SD card slot on the rear face of the camera.

Turn off the camera, remove the protection cap and, with the label side facing rightward, insert an SD card until you hear a click.

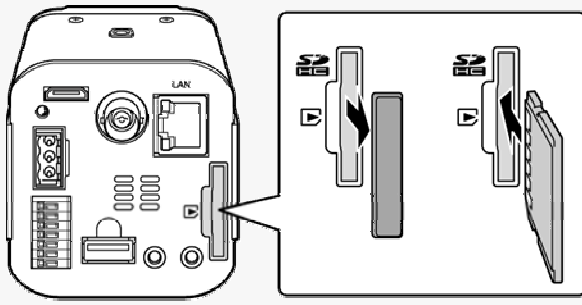

How to remove the SD card

Push the SD card a bit further into the slot to eject it.

External HDD

Use the optional hard disk case (VA-HDC4000) to install the SANYO-specified 2.5" SATA hard disk drive and connect the drive to the EX-HDD terminal.

For detailed information on the hard disk case including hard disk installation, refer to the instruction manual supplied with the hard disk case.

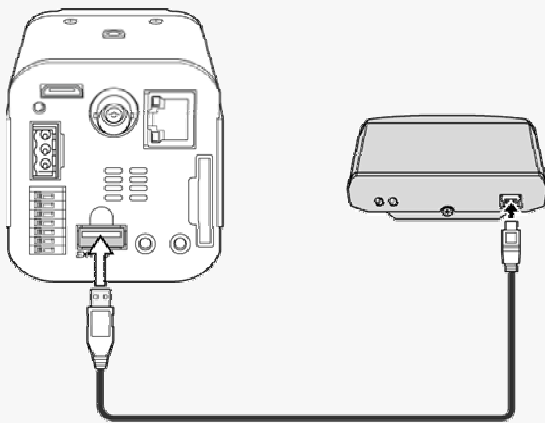

Formatting the recording media

- 1 Use the \triangle/∇ button to select [SD/HDD SET] on the menu screen, and press the SET button.

The total capacity of the installed media and their format statuses appear.

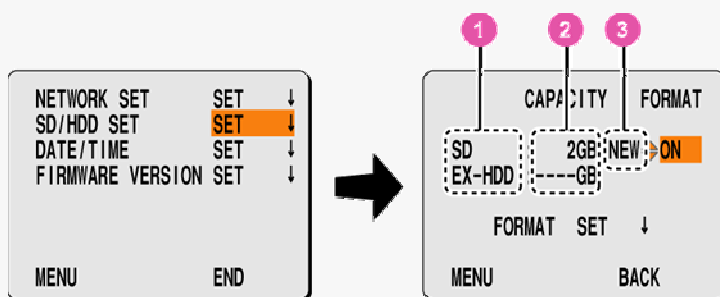

1 Medium Type

SD: SD memory card

EX-HDD: External hard disk

2 Medium Capacity (CAPACITY)

The capacity of each medium will be indicated in units of MB (megabytes) if less than 1 GB (gigabyte). When the SD memory card is not installed on the camera, “---GB” indication appears.

3 Format Status (FORMAT)

NEW: The media is brand-new and required to be formatted.

FMT: The media is already formatted.

---: The camera cannot recognize the media.



If a recording medium is installed while the camera is turned on, “NEW” appears even when it is formatted and the medium may be formatted mistakenly.

2 Use the Δ/∇ button to select the medium to format (ex. SD), and press the SET button.

The \diamond symbol appears beside “ON” or “OFF”.

3 Select “ON” using the Δ/∇ button and press the SET button.

The \diamond symbol disappears and the medium is ready to format.



If the format status for the medium is “NEW”, “ON” is selected automatically.

4 Use the Δ/∇ button to select [FORMAT], and press the SET button.

If the capacity of the medium is lower than or equal to 2GB, it will be formatted with the FAT16 file system; if higher than 2GB, it will be formatted with the FAT32 file system.

When the medium has been formatted, you return to the SD/HDD SET sub menu.

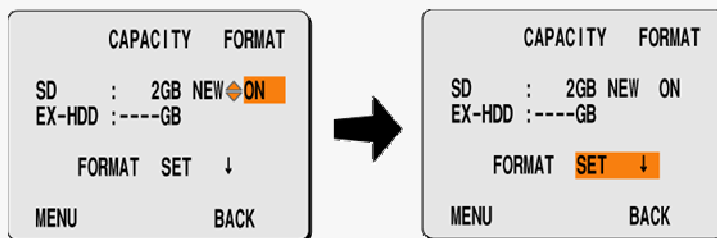

If you try to format the medium that is already formatted and contains data, the following confirmation message appears.

If you proceed to format the media, select “YES” using buttons and press the SET button. Doing this will erase all the recorded data on it.

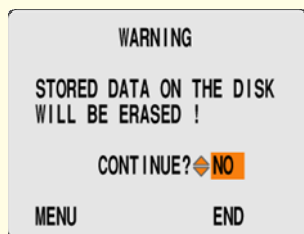

C Setting the date and time (DATE/TIME SET)

You can set the date and time on the camera.

1 Use the Δ/∇ button to select [DATE/TIME SET], and press the SET button.

The date/time setting screen appears.

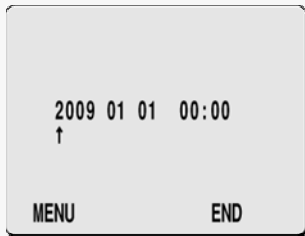

- 2** Move the cursor to the desired position using the  button, select a number in each digit using the  button, and then press the SET button.

The date and time you set are saved and you return to the menu screen.



The date and time can also be configured on the CLOCK SETTINGS screen via network operation.



VCC-HD4600/HD4600P

Chapter 2

Quick Operation Guide

From Connection to Network Operation
Live Video Monitoring
Alarm Detection and Output
Recording Surveillance Video
Software Information
Configuration menu quick reference tables

From Connection to Network Operation

Follow the steps below to set up and connect the camera to your PC.

You can use video recording, bidirectional audio communications, and other standard functions of the camera, in addition to normal live video monitoring.

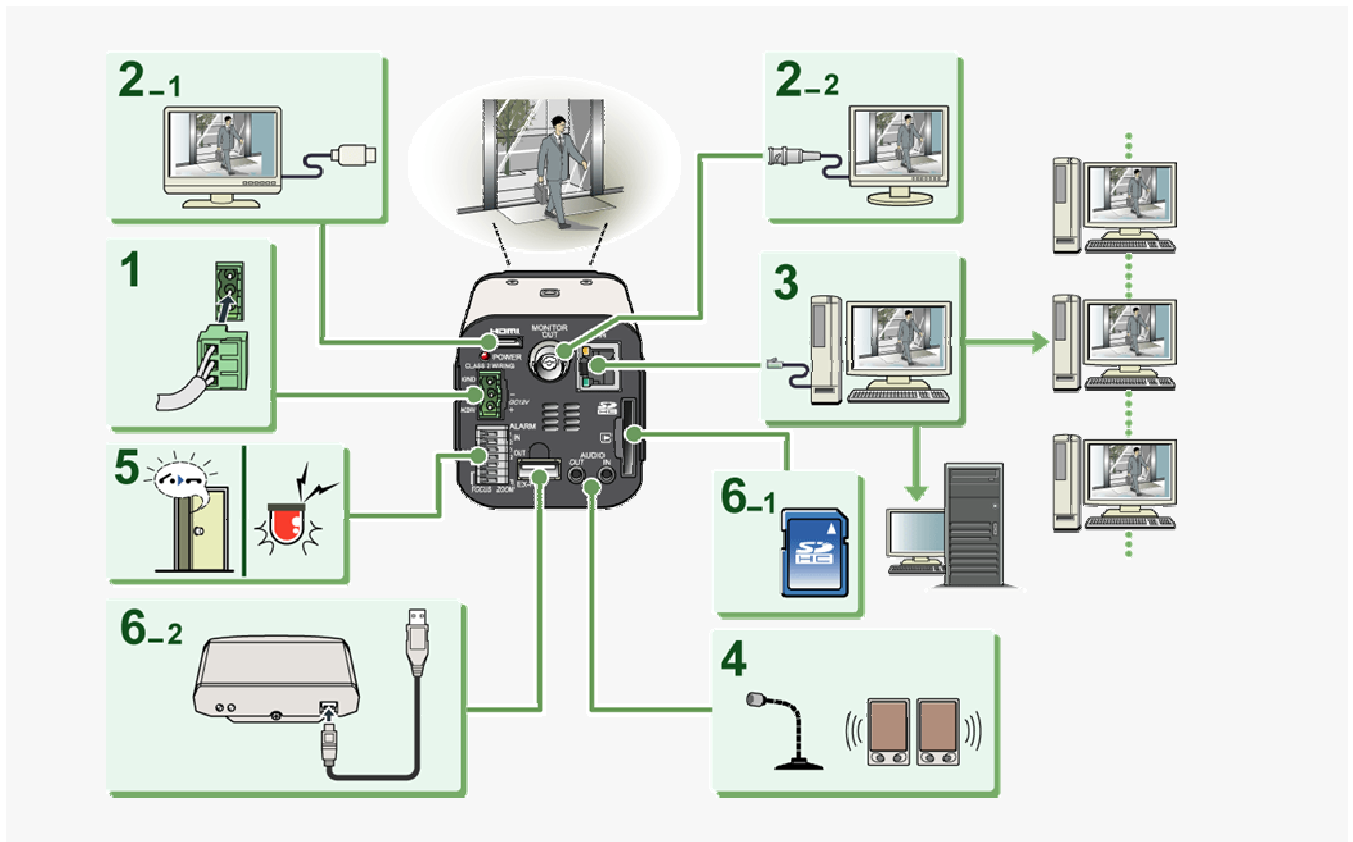

1 Connect the power cable to the power terminals.

Use a 24-VAC or 12-VDC power supply.



Do not turn on the camera until you complete all connections.

2 Connect the monitor to the appropriate terminal.

- 1 High-definition monitor: HDMI terminal
- 2 Monitor for video adjustment: MONITOR OUT terminal



The video cannot be output to the HDMI and MONITOR OUT terminals simultaneously. Set the preferred output terminal under TV OUT on the VIDEO & AUDIO SETTINGS screen.

3 Connect the network (LAN) socket to your PC using a LAN cable.

Check the operating environment of your PC and perform the following operations:

- 1 Check the network information on your PC.
- 2 Install the "H.264 Plug-in" from the supplied CD-ROM onto your PC.

4 Connect a microphone and a speaker system to the audio input and output jacks of the camera.

AUDIO IN jack: Use this jack to connect an external microphone to hear the sound with live video, or simultaneously record the video and sound.

AUDIO OUT jack: Use this jack to connect an amplified speaker system to send audio messages from your PC to the camera.

5 Connect necessary external devices to the alarm input/output terminals.

ALARM IN1/2 terminal: Connect an external switch, infrared sensor, or other device to detect alarm conditions such as entry of an intruder.

ALARM OUT 1/2: Connect a buzzer, lamp, or other alarm device to output a signal to warn people of the occurrence of an alarm condition.

6 Install the recording medium.

After installation, the medium requires to be formatted.

1 SD memory card: Insert it into the SD card slot.

2 External hard disk: Connect the drive to the EX-HDD terminal.

7 Turn on the camera.

The power indicator lights up and live video appears on the monitor.

8 Access the camera from your PC's Web browser.

Live video appears on the live screen. Now, you can perform all network operations from your PC.

Live Video Monitoring

If you are operating the camera for the first time, check the factory default video and audio conditions on the VIDEO & AUDIO SETTINGS screen. Change the default settings as desired. For details, refer to the “VIDEO & AUDIO SETTINGS” section.



A Configuring aspect ratio (ASPECT RATIO)

16:9 (Default) → 4:3

B Configuring video (VIDEO)

By default, the list shows the two stream patterns, STREAM1 and STREAM2. Use the buttons provided below the list to add, change, or delete stream patterns.

The factory default settings for STREAM1 and STREAM2 are as shown in the screenshots below.

ADD : Use this button to add up to two custom stream patterns (STREAM3 and STREAM4).

CHANGE : Use this button to change stream settings (STREAM1 to STREAM4).

DELETE : Use this button to delete registered stream patterns.

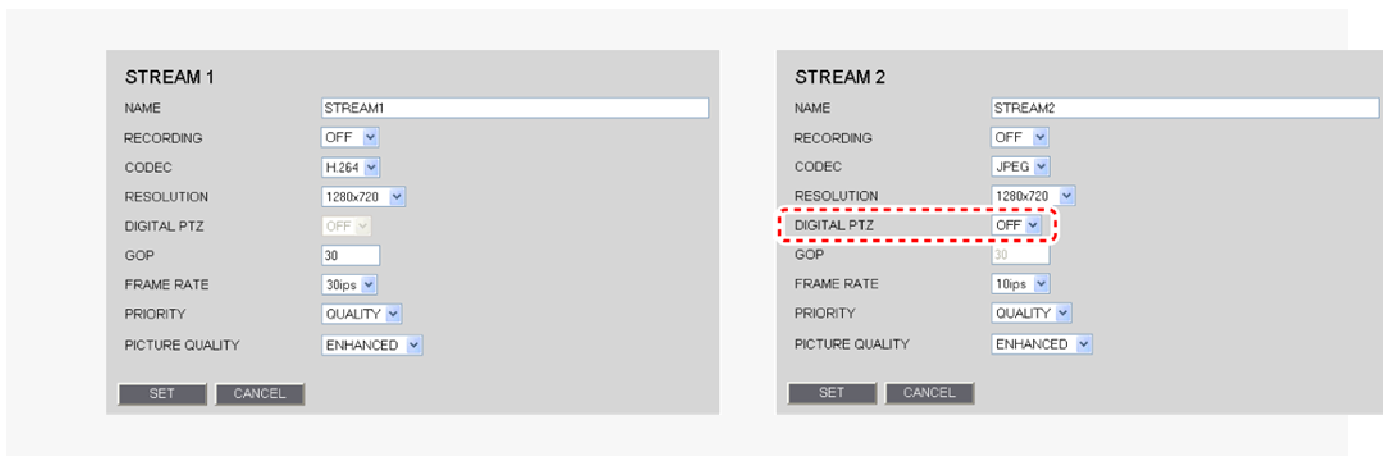

Digital PTZ Function

The digital PTZ function lets you clip specific areas of the subject in VGA size and perform zoom, pan, and tilt operations just as when using a PTZ camera.

To use the digital PTZ function, set [DIGITAL PTZ] to “ON” on the JPEG stream registration screen shown above (STREAM2 screen in this example) and click **DIGITAL PTZ** on the live screen.



You cannot select “ON” in [DIGITAL PTZ] if you selected “H.264” in [CODEC].

Selecting “ON” in [DIGITAL PTZ] fixes the [RESOLUTION] value to a VGA-equivalent size (“640×360” in 16:9 aspect ratio or “640×480” in 4:3 aspect ratio).

C Configuring the audio

Audio condition configuration

In [MIC SENSITIVITY], select the microphone sensitivity.

In [FILTER (500Hz)], enable or disable the audio filter.

In [OUTPUT LEVEL], select the desired audio output level.

Audio output configuration

Set [AUDIO (CAMERA TO PC)] to “ON” on the CLIENT SETTINGS screen.

Audio input configuration

Set [AUDIO (PC TO CAMERA)] to “ON” on the CLIENT SETTINGS screen.

Alarm Detection and Output

If you are operating the camera for the first time, check the factory default alarm detection conditions on the ALARM SETTINGS screen. Change the default settings as desired. For details, refer to the “ALARM SETTINGS” section.

Alarm Detection

You can configure the camera to detect alarm conditions via the “alarm input terminals” or “built-in motion sensor”. For how to configure the camera to detect alarm conditions via the alarm input terminals, refer to the “Alarm Input/Output Terminal Connections” section.



A Detecting an Alarm Condition via Alarm Input Terminal

Connecting an alarm switch, infrared sensor, or other external device to the ALARM IN1/2 terminal enables the camera to detect alarm conditions such as entry of an intruder.

Setting Item	Default Setting	Optional Setting
ALARM IN1/2 (Alarm input terminal number)	OFF (Disables alarm detection.)	ON (Enables alarm detection.)
POLARITY (Signal polarity)	NO (Ex.: Detects an alarm when door is closed)	NC (Ex.: Detects an alarm when door is opened.)
ACTION (action the camera makes when an alarm condition is detected)	OFF (No action)	ZOOM (Zooms to the specified magnification.) CAM1/CAM2 (Switches the monitoring condition.)
DURATION (Alarm retention duration)	5SEC (Ex.: Records alarm video for 5 sec.)	10SEC to 5MIN, CC (Retains the alarm state as long as the alarm signal persists.)

B Detecting an Alarm Condition via Built-in Motion Sensor

The camera uses the built-in motion sensor to detect alarm conditions. The motion sensor detects an alarm condition in three ways as follows.

Setting Item	Default Setting	Optional Setting
MOTION (Use of built-in motion sensor)	OFF (Disables alarm detection.)	A MASKING B DETECT C ANALYTICS
DURATION (Alarm retention duration)	5SEC (Ex.: Records alarm video for 5 sec.)	10SEC to 5MIN, CC (Retains an alarm state as long as the motion alarm persists.)

- A** Disabling motion detection in masked areas
- B** Detecting motion in specific areas
- C** Detecting motion with lines and areas drawn on the screen

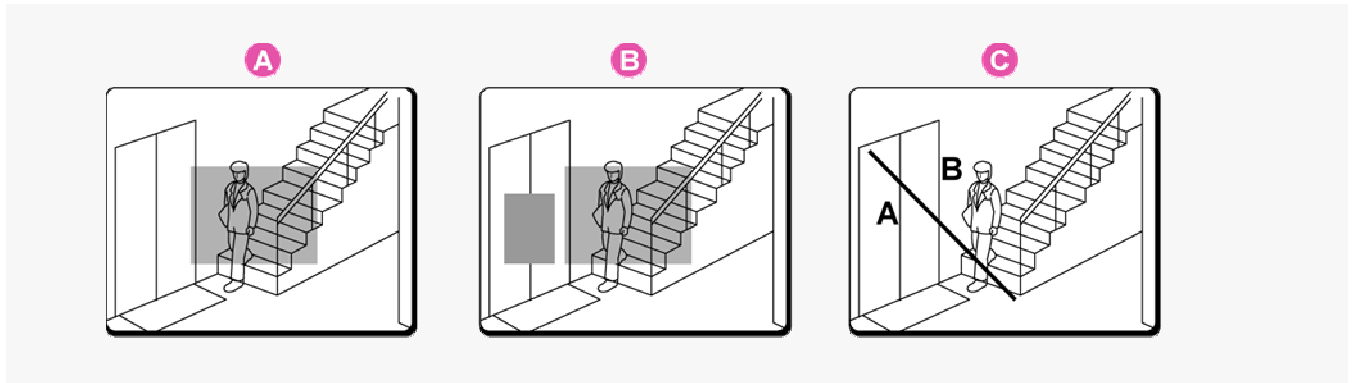

In [MOTION], after selecting a motion sensor type, click **DETAIL** to configure the detection conditions on the detailed configuration screen.

Alarm output

You can configure the camera to “automatically output alarm signals” or “remotely (manually) output alarm signals”.



A Configuring Automatic Alarm Output

You can configure the camera to automatically output an alarm signal when either of its alarm input terminals receives an alarm signal.

ALARM OUT	
SETTING ITEMS	SET VALUE
ALARM OUT1	OFF
POLARITY	NO
ALARM OUT TIME	5SEC
TRIGGER	
ALARM IN	ALARM IN1
MOTION	OFF

Setting Item	Default Setting	Optional Setting
ALARM OUT1/ 2 (Alarm output terminal number)	OFF (Disables alarm output.)	ON (Enables automatic alarm output.)
POLARITY (Signal polarity)	NO	NC
ALARM OUT TIME (Alarm output time)	5SEC (Ex.: Beeps a warning for 5 sec.)	2SEC to 5MIN
ALARM IN (Output condition)	ALARM IN1 (Triggers alarm output when ALARM IN1 terminal receives an alarm signal.)	ALARM IN2 (Triggers alarm output when ALARM IN2 terminal receives an alarm signal.)
MOTION (Output condition)	OFF (Disables alarm output using motion sensor.)	ON (Triggers alarm output using motion sensor.)

B Configuring Remote Alarm Output

Use the Remote Alarm buttons ( ) provided on the live screen to send alarm signals from the camera's alarm output terminals.

ALARM OUT	
SETTING ITEMS	SET VALUE
ALARM OUT1	REMOTE
POLARITY	NO
ALARM OUT TIME	5SEC

Setting Item	Default Setting	Optional Setting
ALARM OUT1/ 2 (Alarm output terminal number)	OFF (Disables alarm output.)	REMOTE (Enables remote alarm output.)
POLARITY (Signal polarity)	NO	NC
ALARM OUT TIME (Alarm output time)	5SEC (Ex.: Beeps a warning for 5 sec.)	2SEC to 5MIN, CC (Stops alarm output when Remote Alarm button is clicked.)

Recording Surveillance Video

Before recording video, install a recording medium (SD memory card or external hard disk) on the camera and perform the following procedures.

You can record the following videos or information on the media.

- Normal recording
- Alarm video recording
- Backup video recording in event of a network failure
- Manual video recording triggered by the emergency recording button
- Access and system logs



In cases where both an SD memory card and an external hard disk drive are simultaneously connected, the hard disk drive takes precedence.

The recorded video cannot be played back on the camera. To play back the recorded video, use the supplied downloader software (HDC Downloader) and playback software (DLViewer) to play back the video on the PC.

1 Click **SD/HDD** in the configuration menu.

On the SD/HDD screen, you can format the recording media.

SETTING ITEMS		SET VALUE
SD MEMORY CARD		NO USE
LOG		OFF
AREA	NORMAL	
	ALARM	
SIZE/FORMAT		NO CARD

Setting Item	Default Setting	Required Setting/Operation
1 SD MEMORY CARD/HDD	NO USE	USE (Use the media for recording)
2 AREA (Ratio of the recording areas)	NORMAL: 80 (Normal recording storage area) ALARM: 20 (Alarm/backup recording storage area)	Change the rate between the "NORMAL" and "ALARM" areas as needed.
3 SIZE/FORMAT	Displays the recording capacity of the media.	Check the storage capacity and click FORMAT .

When finished formatting the SD memory card, close the SD MEMORY CARD screen.

2 Click **RECORDING** in the configuration menu.

On the RECORDING screen, configure the recording settings as follows.

RECORDING HELP

SETTING ITEMS	SET VALUE
NORMAL	OFF
RECORD STREAM	ALARM
ALARM	OFF
NETWORK FAILURE	OFF
NETWORK FAILURE TIME	30SEC
AUDIO	OFF
ALTERATION DETECTION	OFF
ALARM EVENT1	OFF
TRIGGER	ALARM IN1
FRAME RATE	0.1ips
PRE ALARM	OFF

Setting Item	Default Setting	Required Setting
1 RECORD STREAM	OFF	Select the desired stream (STREAM1 to STREAM4).
2 AUDIO	OFF	ON (Records video and sound simultaneously)
3 ALTERATION DETECTION	OFF	ON (Detects tampered images)
4 ALARM EVENT1	OFF	ON You can configure three patterns of recording conditions (for ALARM EVENT1 to 3).
5 TRIGGER (Recording trigger conditions)	ALARM IN1 (Triggers recording when ALARM IN1 terminal receives an alarm signal.)	ALARM IN2, MOTION, ALARM OUT1/2, NETWORK FAILURE
6 PRE ALARM	OFF	ON (Records video for a specific period before alarm occurrence.)
7 REC BUTTON	OFF	ON (Records video using the emergency recording button on the live screen control panel)

When finished configuring the above basic recording settings, configure the recording schedule as required.

3 On the RECORDING screen, click **SCHEDULE**.

SCHEDULE SETTINGS HELP

SETTING ITEMS	SET VALUE
SCHEDULE	OFF
NORMAL RECORDING	START
<input type="checkbox"/> SUN	00 : 00 MON 00 : 00
<input type="checkbox"/> DAILY	00 : 00 - 00 : 00

Setting Item	Default Setting	Required Setting
1 SCHEDULE	OFF	ON (Enables recording schedule configuration.)
2 SUN to SAT (START/END)	00:00/00:00	Configure the start/end time of recording for each day of the week. (Ex.: 08:00/20:00)
3 DAILY	00:00/00:00	Select this check box to set the same start/end time for every day.

When finished configuring the schedule settings, the schedule map appears.

Recording video to your PC

By using the recorder/player application VA-SW3050 Server/Client (optional), you can record and play back streaming video data from the camera on your PC.

To make the maximum use of this camera, we recommend that you use this application.



You can record JPEG images only.

You need to configure recording and other conditions on the application's configuration screens.

Recording video to an FTP server

To record video by sending image data from the camera to an FTP server, you need to configure the image transmission conditions on the FTP SETTINGS screen.



You can record JPEG images only.

Software Information

You can install the following software on your PC to extend the capabilities of your surveillance system.



The CD-ROM that comes with the camera includes all the supplied software.

Supplied Software

A H.264 Plug-in (Plug-in for monitoring live video as high-quality moving images)

This plug-in software is required to display H.264 video on the live screen. Be sure to install it on each computer from which you access the camera via network operation.

B HDC Downloader (Application for downloading the video recorded on the camera's recording media (SD memory card/external hard disk) to the PC)

You can download JPEG image and H.264 video data.

The application lets you search for the video/image data to download by date and time or by alarm event.

It is also possible to connect a recording medium to your PC to directly copy video/image data.

C DLViewer (Application for playing back downloaded alarm video, etc.)

You can play back JPEG image and H.264 video data.

The application also offers the capability to save and print video/image data.

D VA-SW3050Lite (Application for monitoring live video from more than one camera)

This monitoring application is designed for use with SANYO network cameras.

You can access up to 128 cameras simultaneously.

The application lets you monitor video images from connected cameras in either the single screen or the 4-screen, 9-screen, or 16-split screen mode.

E Auto IP Setup (Utility for automatically setting up IP addresses when two or more new cameras are connected)

This utility automatically assigns a unique IP address to each camera that has the factory default IP address ("192.168.0.2").

Using the utility's camera search function, you can check the IP addresses of all cameras existing on the same local network.

It is also possible to check and correct overlapping IP addresses.

Optional Software

VA-SW3050Server/Client (Application for recording and playing back streaming images from camera)

This recorder/player application is designed for use with SANYO network cameras.

This is a complete version of the VA-SW3050 series software, which offers all the functions you need to perform monitoring, recording, search, playback, and other operations in a surveillance system.

This software requires at least two PCs that serve as the server and the client.

Configuration menu quick reference tables

Click **MENU** on the control panel to display the administrator configuration menu that includes a series of menu selection buttons.

If you are a surveillance system administrator, use these buttons to configure necessary settings according to the installation environment and application of your camera.

Configuration Related to Network Connection

Operation	Configuration Screen (Menu)
Changing the camera's IP address.	NETWORK SETTINGS
Using SANYO's DDNS service.	
Using SSL communication.	
Streaming H.264 video in multicast	

Clock and Camera Title Configuration

Operation	Configuration Screen (Menu)
Adjusting clock to specific time based on external input signal	CLOCK SETTINGS
Configuring the camera title	

Configuration Related to Access and Security

Operation	Configuration Screen (Menu)
Registering new users	USER REGISTRATION
Changing the password, user name, and operation privilege of users	
Allowing all users to access the camera without any authentication check	
Restricting PCs that have access to the camera	SECURITY SETTINGS

Configuration Related to Live Video

Operation	Configuration Screen (Menu)
Accessing the camera from video viewer or similar software to view live video	NETWORK SETTINGS
Hiding specific portions of video	CAMERA SETTINGS (PRIVACY MASK)

Alarm-Related Configuration

Operation	Configuration Screen (Menu)
Sending an alarm image via e-mail	E-MAIL SETTINGS
Using the alarm input terminals to switch the camera between the color and black-and-white video modes	CAMERA SETTINGS (DAY/NIGHT)

Recording-Related Configuration

Operation	Configuration Screen (Menu)
Recording video with the camera for backup in the event of a network failure	RECORDING
Recording images from the camera to an FTP server	FTP SETTINGS

Optional Configuration

Operation	Configuration Screen (Menu)
Updating the camera's firmware to the latest version.	OPTION SETTINGS (FIRMWARE UPDATE)
Restoring the factory default settings	OPTION SETTINGS (FACTORY DEFAULT)
Backing up or uploading settings	OPTION SETTINGS (MENU BACKUP/MENU UPLOAD)
Viewing the access log, system log, and operation log	OPTION SETTINGS (LOG)



VCC-HD4600/HD4600P

Chapter 3

Before You Begin Network Operation

- Preparing Your Computer for Network Operation
- Setting Up IP Addresses Automatically (Auto IP Setup)
 - Check your operating environment
 - Configure the network information on your PC
 - Operation Privileges and Login Users

Preparing Your Computer for Network Operation

Follow the steps below to prepare your computer for network operation. For detailed procedure, refer to the linked information.

1 Assign a unique IP address to each camera.

If you have newly installed two or more cameras on your network, you can accomplish this by using the supplied “Auto IP Setup” software.

2 Check your operating environment

3 Connect the camera to the network to which your PC is also connected.

4 Configure the network information on your PC

You need to configure information such as the IP address of your PC.

5 Install the “H.264 Plug-in” from the supplied CD-ROM onto your PC.

You are now ready to monitor the surveillance video in the H.264 format.

6 Access the camera from your Web browser.

From your Web browser (Internet Explorer), access the camera and log into the system as an “admin” user (administrator).



When you log in, you can select the display language on the network operation screens.

7 Monitor live video.

When you access the camera and log into the system, live video from the camera appears on the live screen.



If the live screen displays no or distorted video, check your operating environment and connection conditions.

8 Configure the necessary settings on the administrator configuration screens.

Although the camera is already configured with the factory default settings so that you can monitor live video immediately after you log into the system, you need to configure necessary settings according to your installation environment and application of the camera.



If this is the first access to the camera, start by configuring the system clock on the CLOCK SETTINGS screen.

9 Use associated software applications to extend the capabilities of your surveillance system.

Install the following associated software applications on your PC, as required:

Downloader (supplied): Downloader application for downloading video data recorded with the camera to your PC.

DLViewer (supplied): Player application for playing back downloaded video data.

VA-SW3050Lite (supplied): Monitor application for monitoring video images from more than one camera simultaneously on a multi-view screen.

VA-SW3050Server/Client (optional): Recorder/player application for recording and playing back streaming video data from the network.

Setting Up IP Addresses Automatically (Auto IP Setup)

If you are installing two or more new cameras on the same local network, you need to change the factory default IP address of each camera to prevent IP address overlap. The supplied “Auto IP Setup” software frees you from this burden by automatically assigning a unique IP address to each camera on your network.

Before setting up the IP addresses automatically, click the [Search Cameras] button in the utility window to search all cameras on the network and display the address settings and details of each camera.

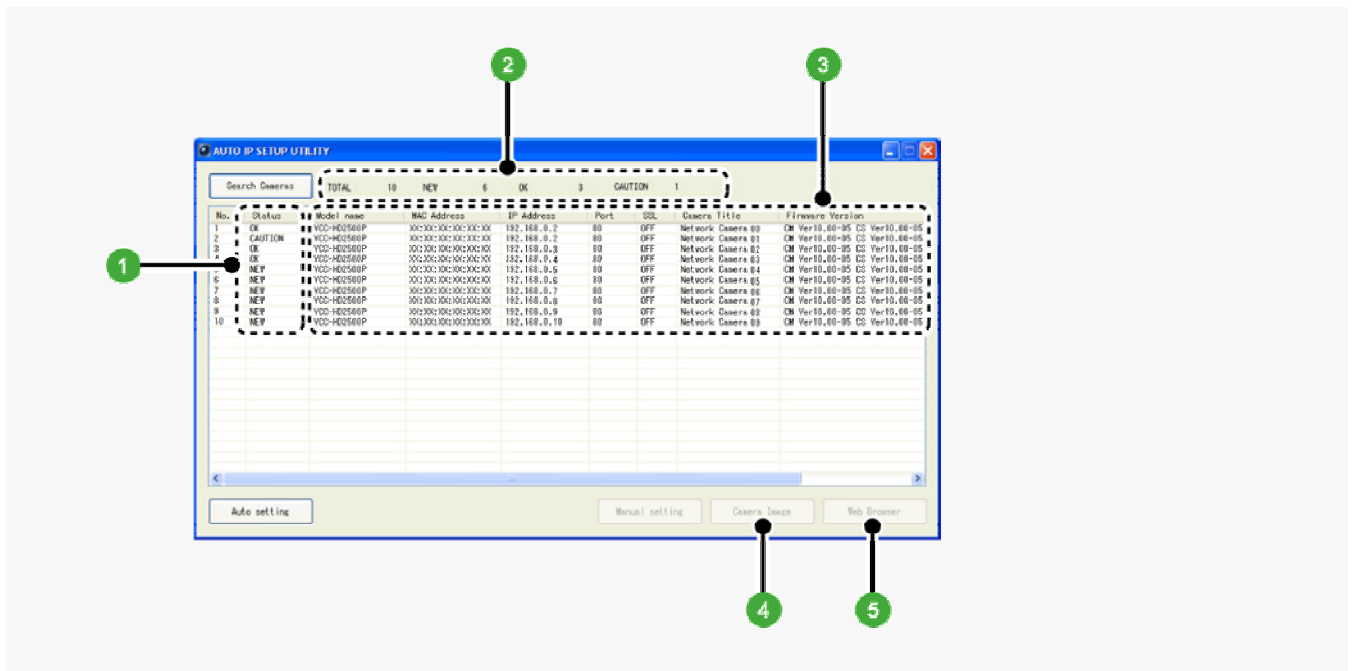

1 Status

- NEW:** The camera has the default IP address (“192.168.0.2”).
→ Assign a unique IP address.
- OK:** The camera has a unique IP address and can be connected successfully to network.
- CAUTION:** The camera cannot be connected successfully to the network because of IP address overlap or other reason.
→ Change the IP address.

2 Number of searched cameras (Total and by status)

3 Camera details



“Model name”, “IP Address”, “Port”, “SSL”, “Camera Title”, and “Firmware Version” are not shown if the network board or other hardware is not supported.

“IP Address”, “Port”, “SSL”, and “Camera Title” are editable. (Refer to the “Manually Setting Up IP Addresses of Existing Cameras” section.)

4 Camera Image button

Select the desired camera row and click this button. Then, video from the camera appears in a separate window. Use it to check which camera is selected or when editing the camera title or other data.

5 Web Browser button

Select the desired camera row and click this button. Then, the Web browser opens and connects to the camera automatically.

Automatically Setting Up IP Addresses of New Cameras

1 Insert the supplied CD-ROM into the CD-ROM drive of your PC.

The opening menu appears.

2 Click [Auto IP Setup].

The utility window opens so that you can search cameras.



If you encounter a firewall confirmation dialog box, disable the firewall so that your PC can communicate with the camera.

3 Click **Search Cameras**.

The utility searches all cameras on the local network and shows information on each camera one after another.

The screenshot shows the 'AUTO IP SETUP UTILITY' window. A green box with the number '3' and an arrow points to the 'Search Cameras' button. The window displays a table with columns: No., Status, Model name, MAC Address, IP Address, Port, SSL, Camera Title, and Firmware Version. The table lists 10 cameras, with the first three having a status of 'CAUTION' and the remaining seven having a status of 'NEW'. A second green box with the number '4' and an arrow points to the 'Auto settings' button at the bottom left. An 'AUTO SETTING' dialog box is open in the foreground, prompting the user to enter a start or end address for auto setup. The 'Auto setup range' section shows 'from 192.168.100.4 to' followed by an empty input field. The dialog box has 'Execute' and 'Cancel' buttons.

The above screenshot shows an example when your PC is connected to 10 cameras.

4 Click **Auto setting** and, in the address range selection dialog box, click **EXECUTE**.

The utility automatically assigns a series of new IP addresses, starting from the start address.



The “default gateway address of PC + 1” is initially displayed as the start address. To specify your own address range, type both the start and end IP addresses.

The utility automatically assigns an IP address to each camera located in the LAN, but not beyond the router.

It skips any IP address that is already used.

Manually Setting Up IP Addresses of Existing Cameras

If you find that the searched cameras have overlapping IP addresses (indicated by a status of “CAUTION”) or if you need to change a camera title, you can edit the displayed camera data manually as described below.

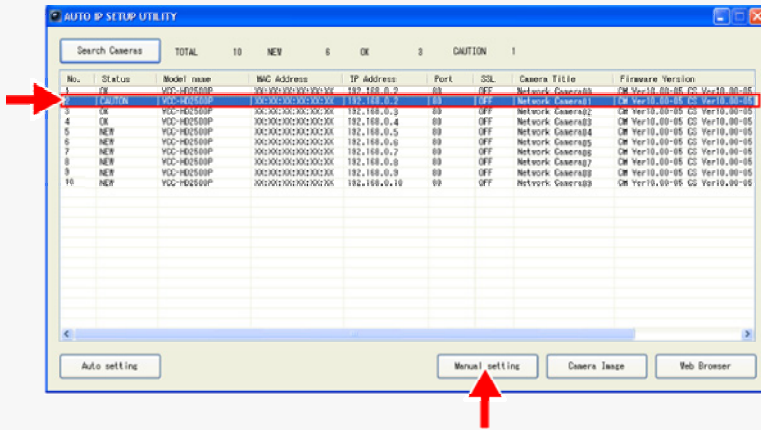

1 Select the desired camera and click **Manual setting** .

The camera information dialog box opens.

2 Make changes to the camera data and click **EXECUTE** .

This transmits your changes to the camera.

You can see the problem of IP address overlap has been resolved in the [Status] row of the list, which has been changed from “CAUTION” to “OK”.



You cannot change the model name.

If your login user name and password has been changed from the factory default settings, you will be presented with an authentication check dialog box. In this case, type the current user name and password.

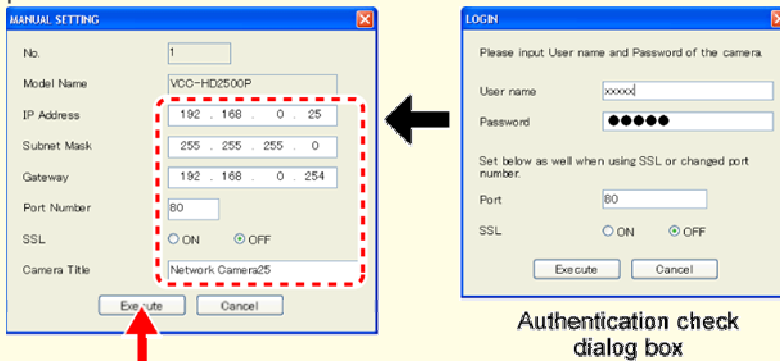

If SSL communication is enabled for the selected camera, you cannot edit the camera data. Change the SSL and port number settings in the authentication check dialog box.

Check your operating environment

To operate the camera via network operation, you must meet the following operating requirements.

- PC:** IBM PC/AT compatible
- Operating system:** Windows XP Professional/Windows Vista
- CPU:** Core2Duo E6700 2.66 GHz or higher
- Memory:** Windows XP: 1GB or more
Windows Vista: 2GB or more
- Network interface:** 10BASE-T/100BASE-TX (RJ-45 connector)
- Display card:** 1920×1200 pixels or higher
- Graphics chip:** ATI RADEON HD2600 series or higher
nVIDIA GeForce 8600 series or higher
nVIDIA Quadro FX550 series or higher
- Web browser:** Internet Explorer Ver. 6.0 SP2 or higher, or Internet Explorer Ver. 7.0



- Use a LAN cable no longer than 100 m (109.4 yards) with the shield type CAT5 or higher.
- The live video may be delayed depending on your system environment.
- Use Windows Update to keep the operating system and browser up-to-date.
Note, however, that Internet Explorer 8 is not supported.

Configuring the Web Browser

In the cases below, configure the Internet Explorer's settings by clicking [Tool] and then [Internet Options].

When accessing the camera using SSL encryption for video signal transmission

- 1 Click the [Advanced] tab.
- 2 Make sure that the [Use SSL 2.0] and [Use SSL 3.0] check boxes under [Security] are selected. If deselected, select them.

When the video refresh is unstable

- 1 Click the [General] tab.
- 2 Under [Temporary Internet Files], click [Settings].
For Windows Vista, click [Settings] under [Browsing history].
- 3 Set the slider under [Amount of disk space to use:] to a low value (the minimum value recommended by Microsoft).

When a Java Script “Runtime Error” is displayed during operation

- 1 Click the [Advanced] tab.
- 2 Under [Browsing], deselect the [Display a notification about every script error] check box.
- 3 Select the [Disable script debugging] check box.

Configure the network information on your PC

For Windows XP

- 1 In [Control Panel], click [Network and Internet Connections].

The [Network and Internet Connections] dialog box opens.

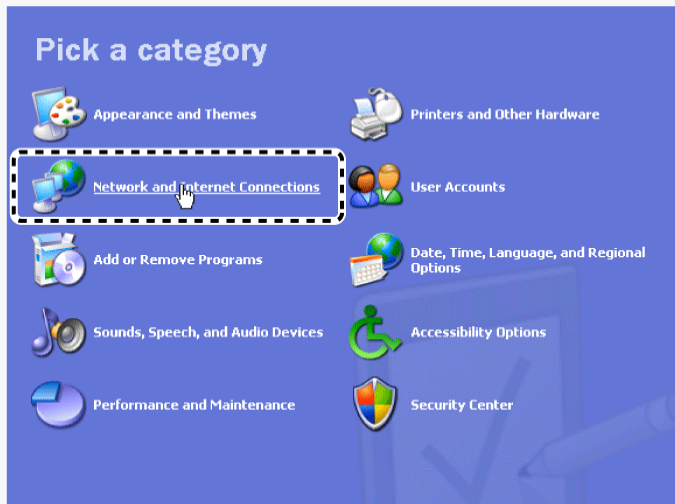

- 2 Click [Network Connections].

The [Network Connections] dialog box opens.

Under [LAN or High-Speed Internet], the icon representing your LAN interface (Ethernet adapter) configuration appears.

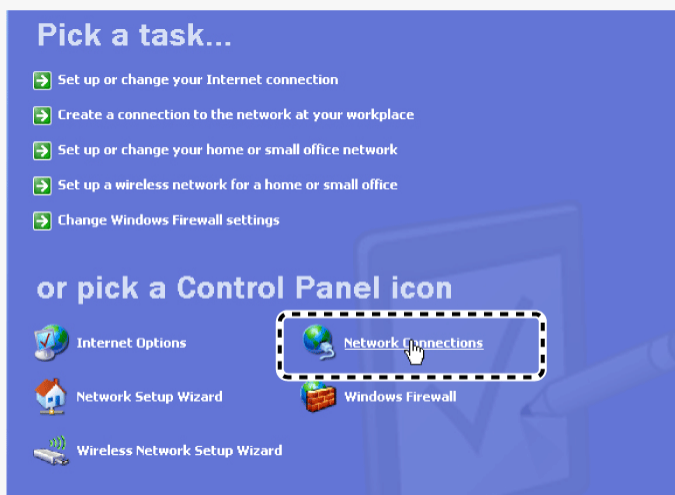

- 3 Right-click on the LAN interface (Ethernet adapter) configuration icon and click [Properties] in the context menu.

The [Local Area Connection Properties] dialog box opens, with the [General] tab shown.

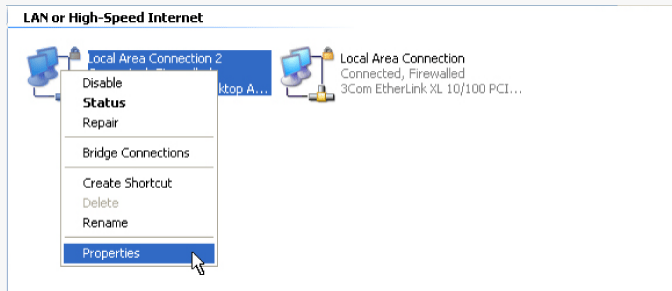

4 In the [This connection uses the following items:] list box, select the [Internet Protocol (TCP/IP)] check box.

Confirm that the [Internet Protocol (TCP/IP)] check box is selected. If deselected, select the check box.

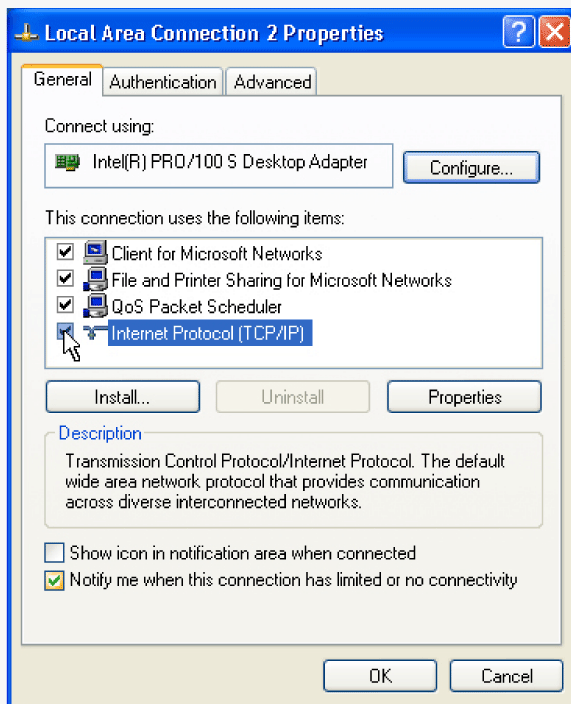

5 Click [Properties].

The [Internet Protocol (TCP/IP) Properties] dialog box opens, with the [General] tab shown.

- 6 Select the [Use the following IP address:] radio button and specify the IP address, the subnet mask, and the default gateway.

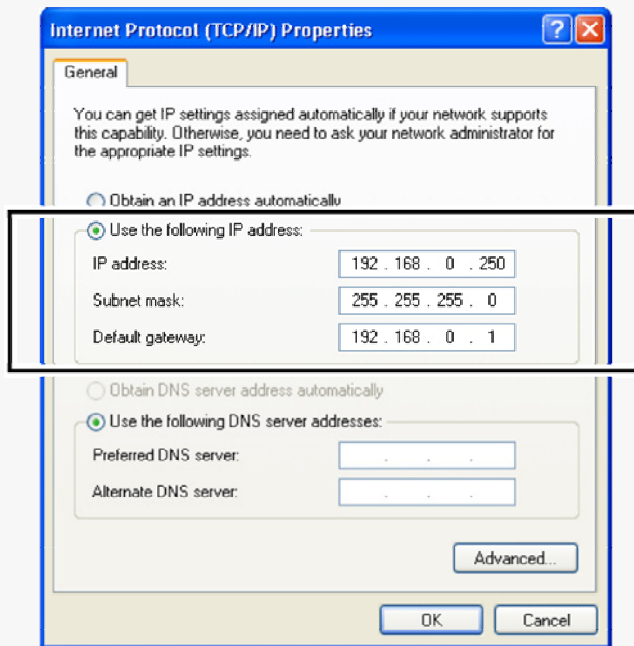

- 7 Check the configured settings and click **OK**.

You are now done with the TCP/IP configuration.
Close all the dialog boxes that are open.

For Windows Vista

- 1 In [Control Panel], click [Network and Sharing Center].

The [Network and Sharing Center] dialog box opens.

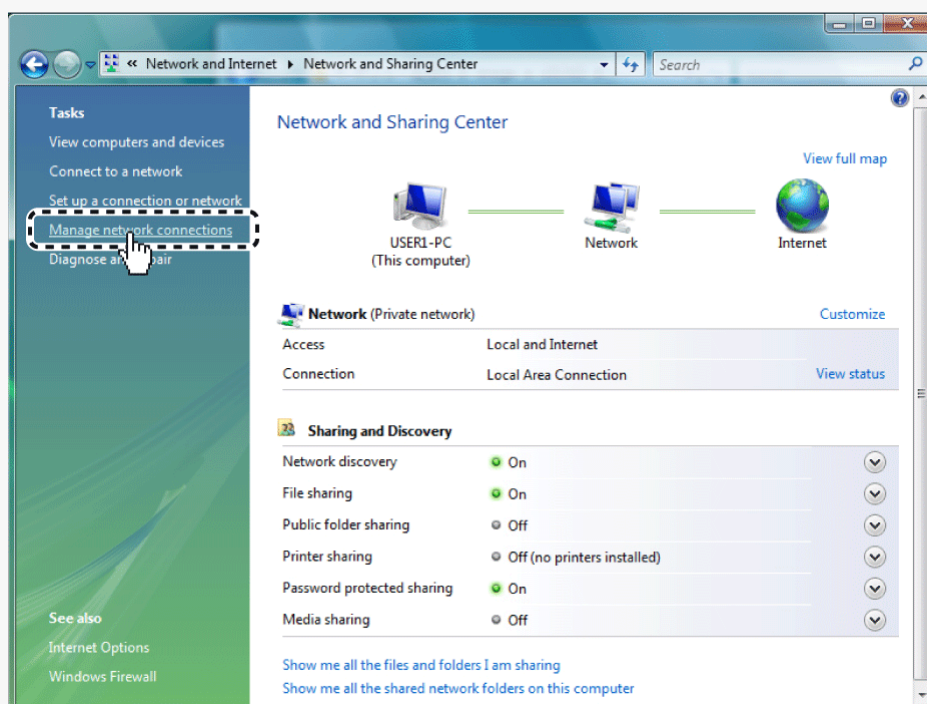

2 Click [Manage network connections].

The [Network Connections] dialog box opens.

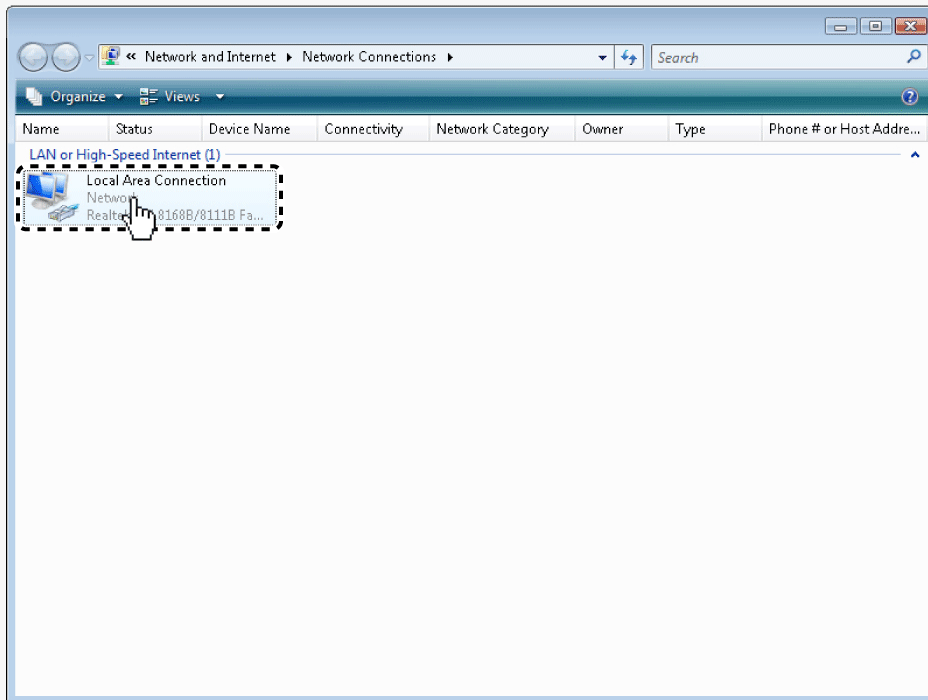

3 Double-click [Local Area Connection].

The [Local Area Connection Status] dialog box opens.

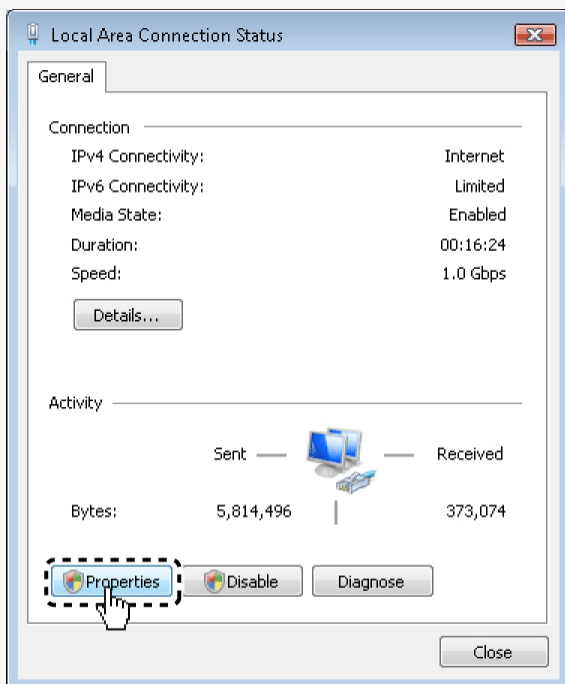

4 Click [Properties] and, in the confirmation dialog box, click [Continue].

The [Local Area Connection Properties] dialog box opens.

5 Select the [Internet Protocol Version 4 (TCP/IPv4)] check box.

Confirm that the [Internet Protocol Version 4 (TCP/IPv4)] check box is selected.
If deselected, select the check box.

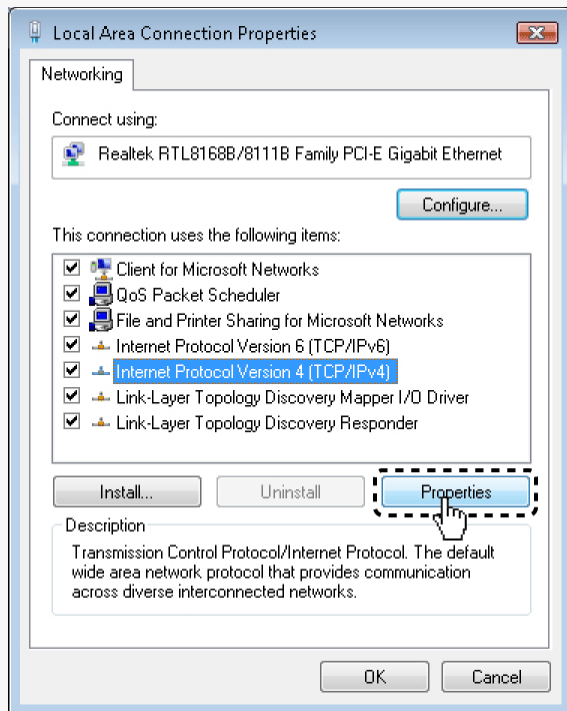

6 Click [Properties].

The [Internet Protocol Version 4 (TCP/IPv4) Properties] dialog box opens, with the [General] tab shown.

7 Select the [Use the following IP address:] radio button and specify the IP address and the subnet mask.

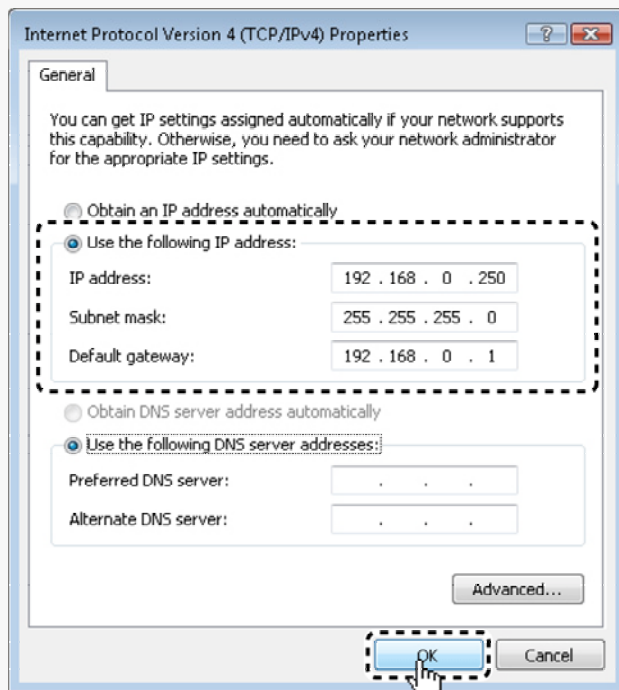

8 Check the configured settings and click [OK].

You are now done with the TCP/IP configuration. Close all the dialog boxes that are open.

Operation Privileges and Login Users

Operation Privileges

The operation privileges of users who perform network operation are divided into 5 levels (admin, operator1, operator2, guest, and download). Each user who attempts to access the camera will be authenticated by the user name and password at login and granted an appropriate operation privilege.

Operation	Operation Privileges				
	admin	operator1	operator2	guest	download
Monitor live video.	○	○	○	○	○
Hearing sounds from camera	○	○	○	○	○
Sending audio messages to camera	○	○	○	–	–
Using digital PTZ function	○	○	○	–	–
Changing your own password	○	△	△	△	△
Selecting a live video stream	○	△	△	△	△
VIDEO & AUDIO SETTINGS	○	○	–	–	–
Configuring settings	○	□	–	–	–
Zoom/Focus/Preset operation button section	○	○	○	–	–
Remote Alarm Buttons	○	○	○	–	–
Emergency recording button	○	○	○	–	–
Downloading data recorded on camera to PC	–	–	–	–	○

- ▶ ○ : Available
- ▶ □: Available (Excluding NETWORK SETTINGS)
- ▶ –: Unavailable
- ▶ △: Available only if permitted by a user with the admin privilege (hereinafter referred to as “admin user”) on the USER REGISTRATION screen



“download” is the operation privilege required for using the supplied downloader application (HDC Downloader).

Disabling authentication check at login

You may set [ANONYMOUS USER LOG IN] to “ON” on the USER REGISTRATION screen to allow anyone to access the camera without any authentication check at login.



In this case, all login users are regarded as guest users. This means that users will be presented with an authentication check dialog box if they attempt to perform any operation beyond the guest user privilege and must enter an adequate user name and password to proceed.

Default Users and Client Users

The camera provides one factory-set default user per operation privilege. Besides these users, you can register up to 20 custom users as client users.

Default users (5 users)

When you access the camera for the first time, login as an admin user and perform the necessary configurations.

Operation Privileges	User	Password (Default)
admin	admin	admin
operator1	operator1	operator1
operator2	operator2	operator2
guest	guest	guest
download	download	download



The factory default users cannot be deleted.

Update your password periodically for security reasons.
For details, refer to the “USER REGISTRATION” section.

If you forget your password, use the buttons provided on the left-side face of the camera to restore the default user passwords.

For details, refer to the topic “Side Face” in the “Name and Function of Each Component” section.

Client users (Max. 20 users)

Using the admin user privilege, you can set up to 20 client users as desired, by specifying the user name, password, and operation privilege information.

For details, refer to the “USER REGISTRATION” section.



You may set two or more admin users.

Limitation of Simultaneous Connections

Up to 20 users have access to one camera at a time.



If two or more users with the same operation privilege, for example, two admin users, log into the system, the user who log in last will take precedence.

If you need to limit the PCs allowed (or disallowed) to access the camera for security reasons, you can register the IP addresses of those PCs on the SECURITY SETTINGS screen.

Updating of live video may become slower depending on your system environment as the number of login users increases.

The number of users who can connect to the system simultaneously may be limited depending on the display resolution setting.

Using the supplied “VA-SW3050Lite” monitoring software or the optional “VA-SW3050 Server/Client” recording/playback software also provides simultaneous access to the camera from your Web browser. However, if the user who is using the software configures one of the following settings, the Web-based admin user will be disconnected from the camera.

- Camera Setting
- Normal Recording & Live Setting (JPEG)
- Live Setting (H.264)
- Alarm Setting



VCC-HD4600/HD4600P

Chapter 4

Working with Live Screen

Access the camera from your Web browser.

Live Screen Components

Control panel

Tool panel

Information bar

Access the camera from your Web browser.

1 Start Internet Explorer.

The supported Web browser is Internet Explorer Ver.6.0 SP2 or higher, or Internet Explorer Ver.7.0.

2 In the address bar, type the IP address of the camera and press [Enter] key.

When you access the camera, the login screen appears.

If this is the first access to the camera, in the Address bar, enter the default IP address as follows.

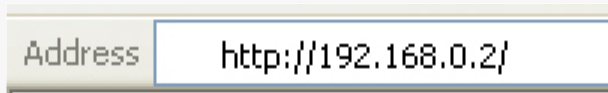

Address



If [SSL] on the NETWORK SETTINGS screen is set to "ON", input "https://" before entering the IP address.

Attempts to access the camera using the default IP address will fail if that address is already being used by another device in the network.

If so, change the IP address of the existing device before accessing the camera.

3 Type your user name and password and click **OK**.

The language selection screen appears.



Connect to 192.168.0.2

You need ID

User name:

Password:

Remember my password

OK Cancel



When you access the camera for the first time, login as an admin user and perform the necessary configurations.

User name and password default values are as follows:

- User name: admin
- Password: admin

4 Click the button corresponding to the language you want to use.

The live screen appears.

From the second login onwards, the live screen appears automatically by skipping the language selection screen.



<Available languages>

▶ English, French, German, Spanish, Japanese



You can display the language selection screen by using the **LANGUAGE** button on the live screen control panel.

If this is the first access to the camera, configure the system clock on the CLOCK SETTINGS screen.

Accessing Two or More Cameras Simultaneously

You can access only one camera at a time from your Web browser.

To access two or more cameras from your PC simultaneously, use the following software.

Monitoring software “VA-SW3050Lite” (Supplied)

Installing this software adds to your PC the capability to simultaneously access two or more cameras and monitor live video from all connected cameras on a multi-view screen.

Recording software “VA-SW3050Server/Client” (Optional)

This software is higher-grade software than “VA-SW3050Lite” that adds recording and playback capabilities to your PC, in addition to video image monitoring.

This software requires at least two PCs that serve as the server and the client, respectively.

Live Screen Components

When you access and log into the camera successfully, the live screen appears.
For details, refer to the linked information.

- Video display area (A)
- Control Panel (B)
- Tool Panel (C)
- Information Bar (D)

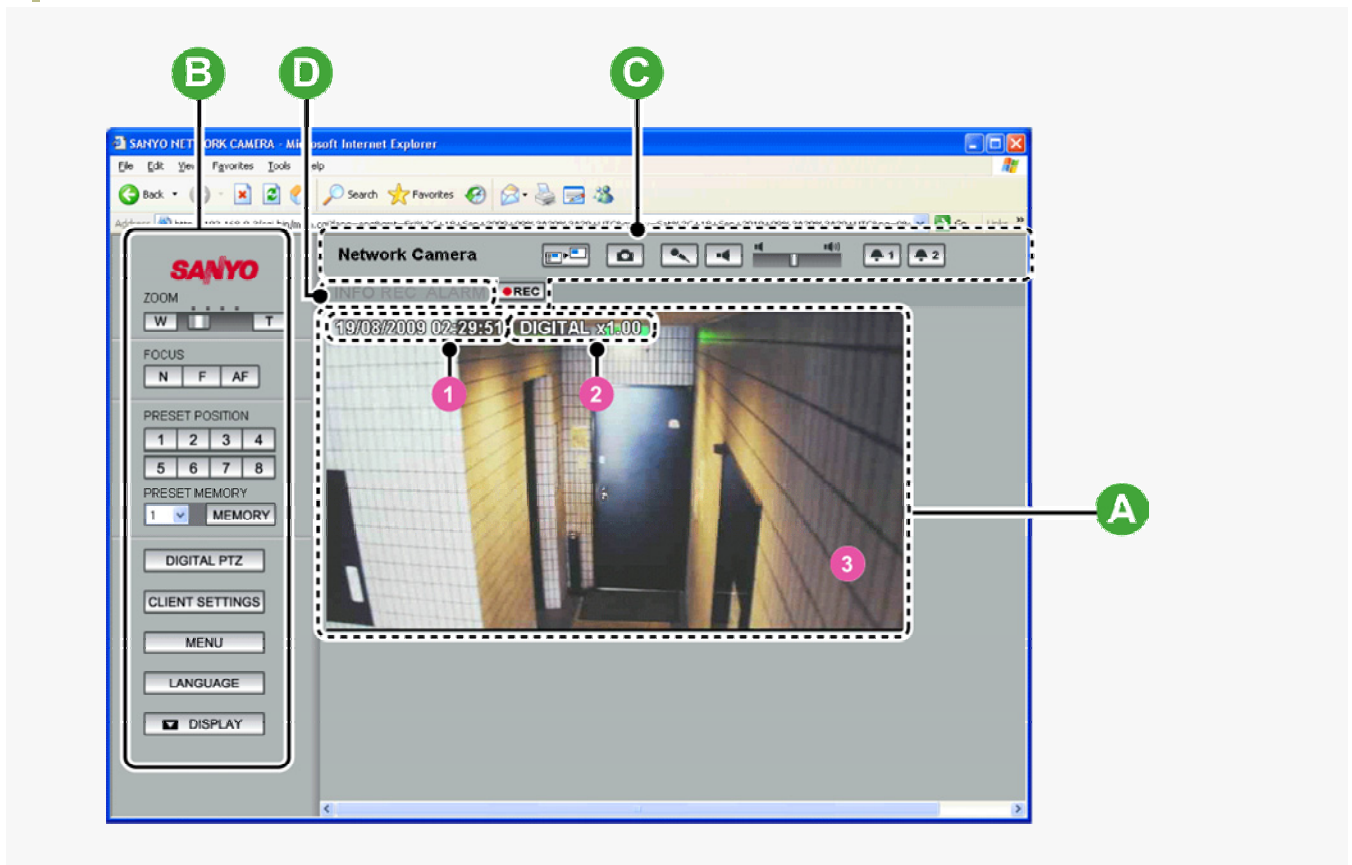

Video display area (A)

1 Current date and time

Shows the current date and time based on the clock settings configured on the CLOCK SETTINGS screen.



You may change the date-time format (month/day/year, year/month/day, or day/month/year), clock type, character size, and display position on the CLOCK SETTINGS screen.

2 Zoom magnification

The current zoom magnification is displayed.



During zoom operation of the digital PTZ function, "DIGITAL" appears to the left of the zoom magnification.

3 Video/image display

Shows **JPEG** images or **H.264** video.

To change the video/image stream displayed on the live screen, click **CLIENT SETTINGS** on the control panel and, on the CLIENT SETTINGS screen, select the desired stream.

Control panel

Click buttons according to your operation purpose.
For details, refer to the linked information.

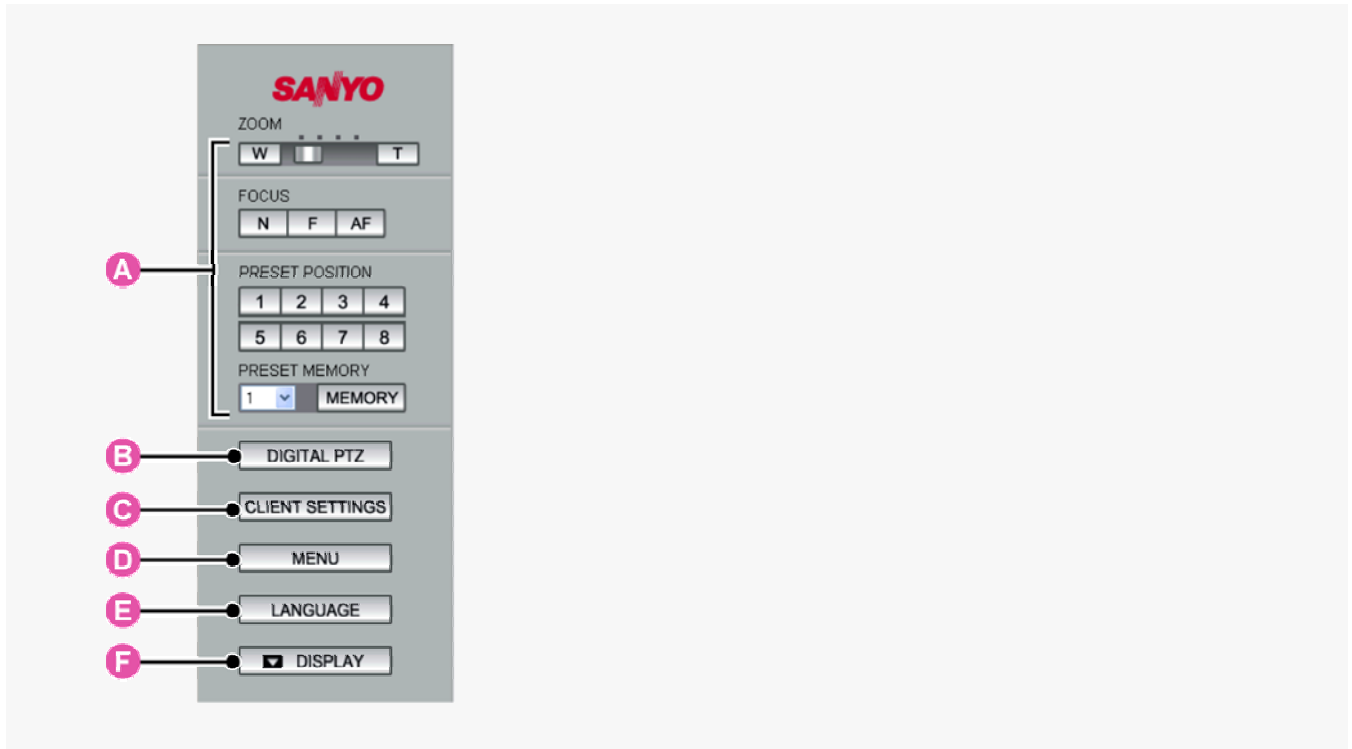

A Zoom/Focus/Preset operation button section

B **DIGITAL PTZ** : Click this to use the digital PTZ function.

C **CLIENT SETTINGS** : Click this to select the live stream and streaming protocol for each user.

D **MENU** : Click this to display the configuration menu.

E **LANGUAGE** : Click this to display the language selection screen.

F **DISPLAY** : Click this to display the image size adjustment panel.

Zoom/Focus/Preset operation button section



Required operation privilege: admin, operator1, operator2



1 Zoom Buttons

You can change zoom magnification by operating the slide bar and buttons.

W (WIDE): Zooms out.

T (TELE): Zooms in.

Zooming continues if the button is kept depressed.



In case electronic zoom is enabled, you can activate the electronic zoom by clicking the **T** button after the maximum optical zoom magnification (10x) is exceeded.

Electronic zoom magnification: 2x, 4x, 8x, 16x

2 Focus Buttons

Click the buttons to adjust the focus.

N (NEAR): Focus on a near object

F (FAR): Focus on a distant object

AF (AUTO FOCUS): Automatic focus

3 PRESET MEMORY/POSITION Buttons

PRESET MEMORY

Select the number (1 to 8) to register from the pull-down menu, and click **MEMORY** button.

The current zoom and focus status is registered as a preset position with the number you select.

PRESET POSITION

Click the preset position number button (**1** to **8**).

The camera restores the zoom and focus status registered with the number.

Using Digital PTZ Function (DIGITAL PTZ)

While monitoring the subject on the live screen, you can use the digital PTZ function to clip specific areas of the subject in VGA size and perform the following operations just as when using a PTZ camera.

To perform this operation, you need to set [DIGITAL PTZ] to "ON" on the VIDEO & AUDIO SETTINGS screen (administrator configuration screen).

This enables the **DIGITAL PTZ** button on the control panel, so you can display the digital PTZ controller (hereinafter referred to as "controller").

- A** Clipping areas of subject
- B** Zooming
- C** Displaying clipped areas sequentially
- D** Automatic panning/tilting
- E** Manual panning/tilting

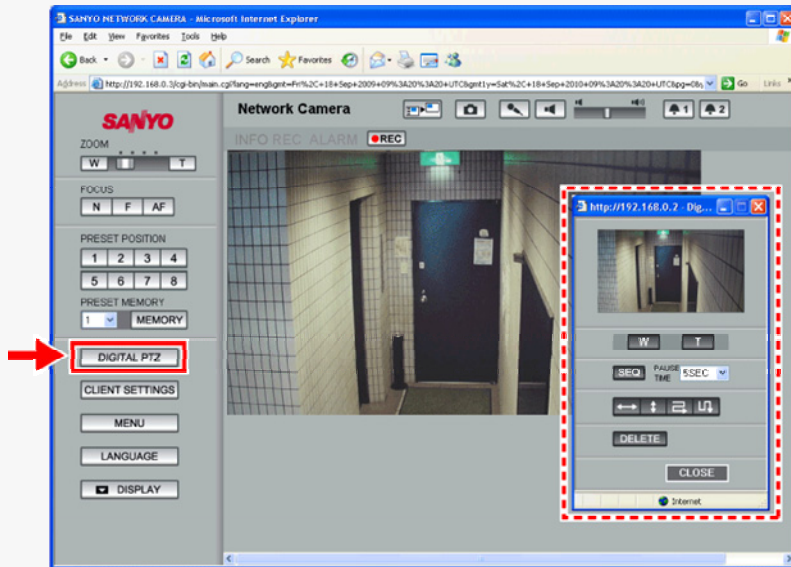

Required operation privilege: admin, operator1, operator2

This function is available for JPEG streaming images only.

You can move the controller to the desired position by dragging with the mouse.

Click **CLOSE** to close the controller.



You can set clipping rectangles independently for each stream. To change the stream, select [LIVE STREAM] on the CLIENT SETTINGS screen.

A Clipping areas of subject

You can set up to four clipping rectangles anywhere in the image display area of the controller.

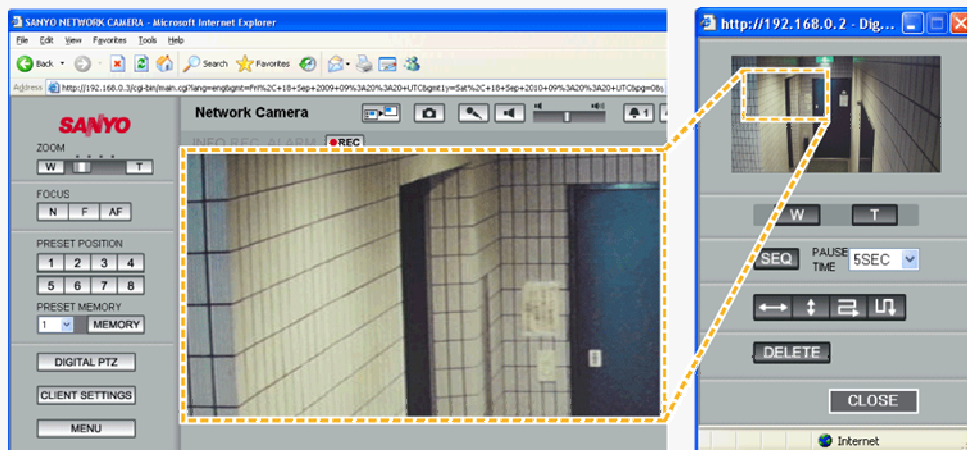

Setting a clipping rectangle:

Click anywhere on the image display area of the controller. This sets a VGA-size clipping rectangle at the point you clicked.



Clipping rectangles may be set in an overlapping manner.

Selecting a clipping rectangle:

Click a clipping rectangle. The selected rectangle turns orange and the clipped area of the subject appears on the live screen.

Deleting a clipping rectangle:

Select a clipping rectangle and click **DELETE** .

B Zooming

You can have the camera electronically zoom in a clipped area.

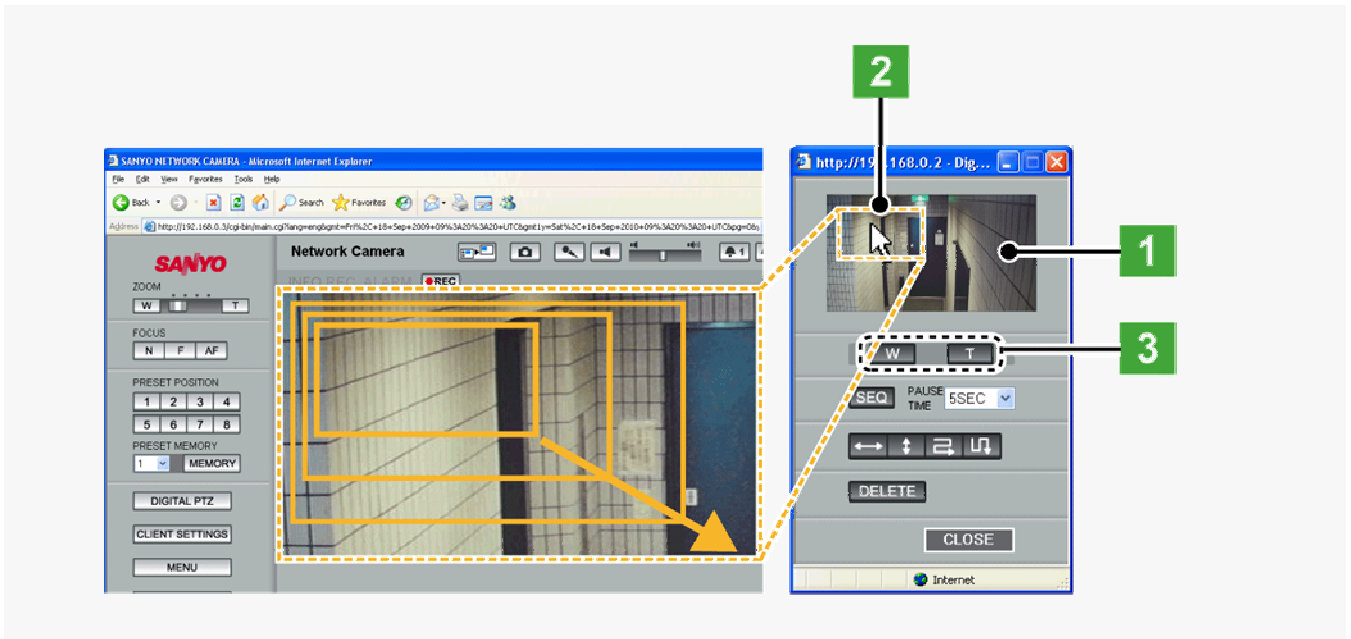

1 Select a clipping rectangle in the image display area of the controller by clicking.

The clipped area of the subject appears in the image display area of the live screen.

2 Drag the clipping rectangle to the position you want to zoom in.

3 Click **W** (WIDE) or **T** (TELE).

The area within the rectangle is zoomed in.

► Zoom magnification: 1, 1.4, 2



During zooming operation, the zoom magnification appears on the live screen.

C Displaying clipped areas sequentially

You can monitor two or more clipped areas of the subject one after another by automatically switching them.

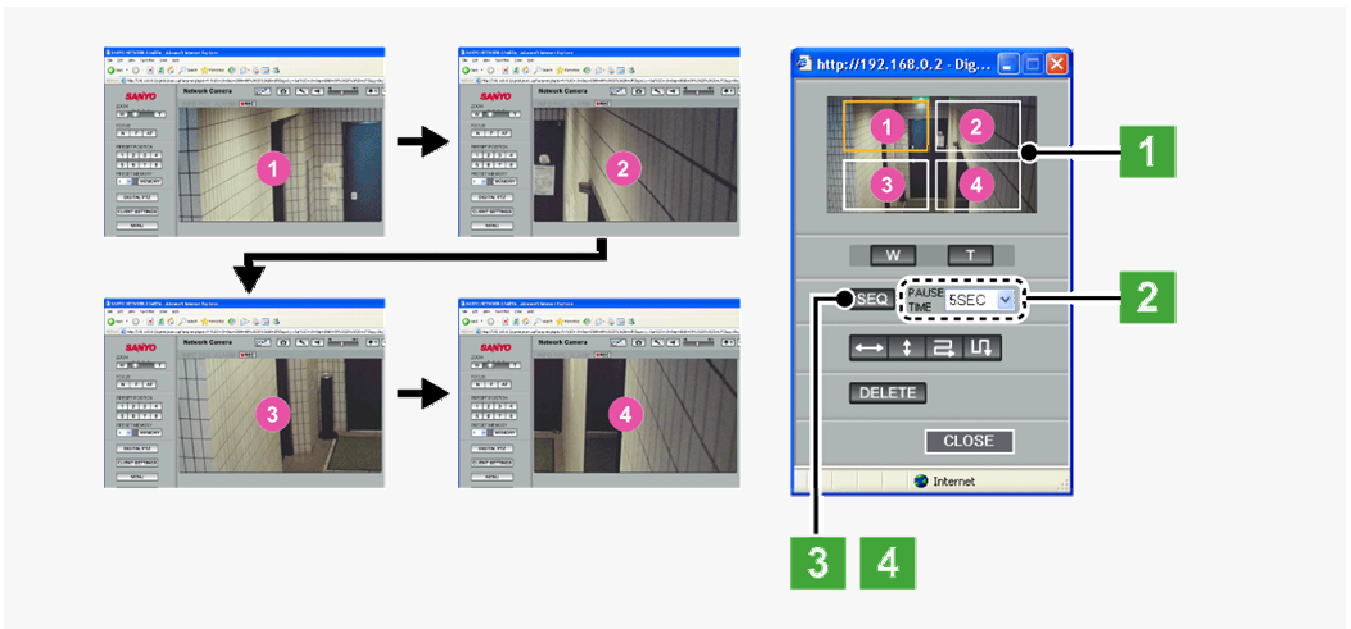

1 Set two or more clipping rectangles.

2 In [PAUSE TIME], select the display interval.

▶ 2SEC, 3SEC, 4SEC, 5SEC, 6SEC, 7SEC, 8SEC, 9SEC, 10SEC, 15SEC, 30SEC

3 Click **SEQ** (shown in gray).

The button turns orange and the clipped areas of the subject appear sequentially in numeric order.

4 Click again **SEQ** (shown in orange).

Alternatively, you may click in the image display area of the controller or on the live screen.

The system stops displaying the clipped areas sequentially and the button color returns to gray.

D Automatic panning/tilting

You can have a clipped area pan/tilt automatically. Four patterns of auto panning/tilting are available as shown below.

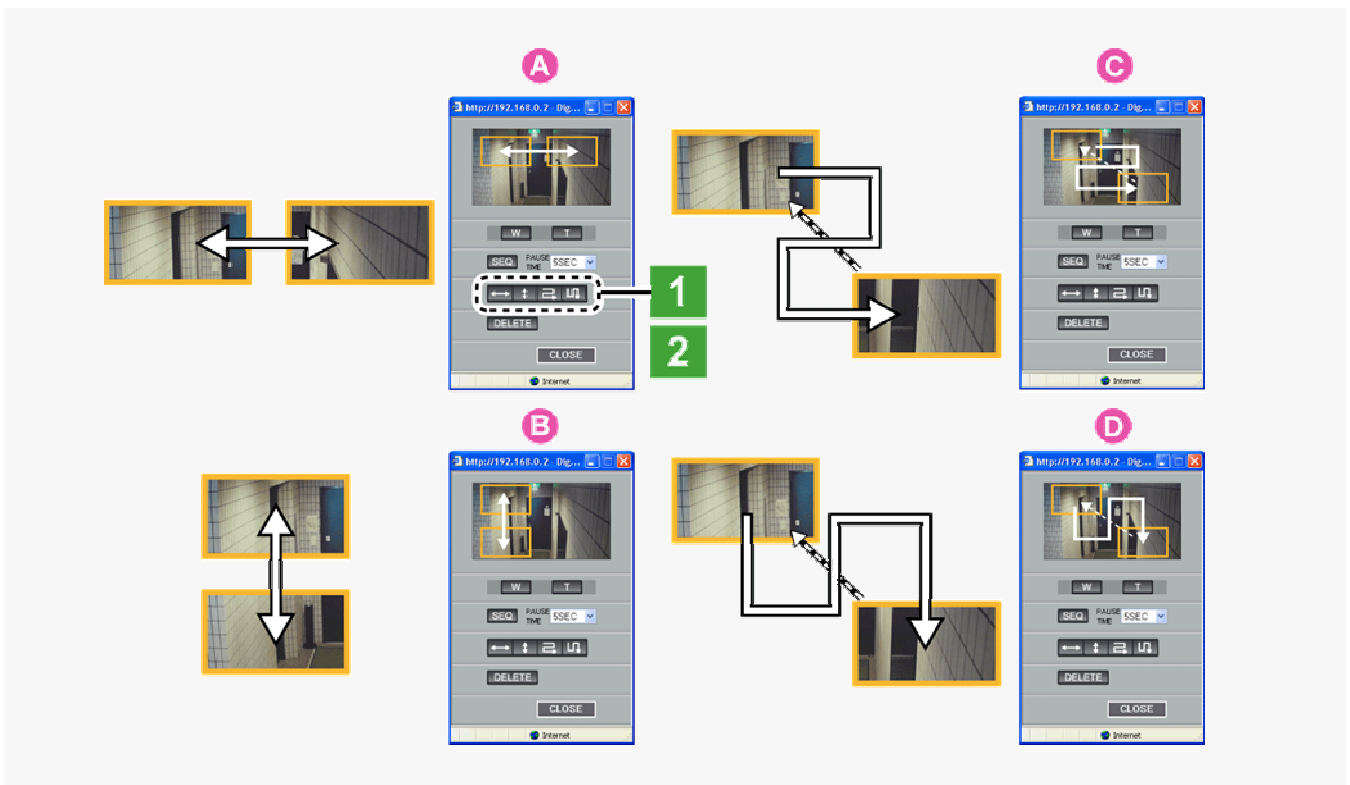

1 Click the Auto Pan/Tilt button (shown in gray).

The button turns orange and the clipped area starts the corresponding movement.

A : Auto pan: The clipped area reciprocates left and right.

B : Auto tilt: The clipped area reciprocates up and down.

C : Auto pan and tilt: The clipped area moves from the top left corner to the bottom right corner while repeating horizontal (right-left) reciprocating movement.

D : Auto pan and tilt: The clipped area moves from the top left corner to the bottom right corner while repeating vertical (up-down) reciprocating movement.

2 Click the Auto Pan/Tilt button (shown in orange).

Alternatively, you may click in the image display area of the controller or on the live screen.

The clipped area stops the movement and the button color returns to gray.

E Manual Panning/Tilting

You can move a clipped area manually in all directions, up, down, right, and left.

1 Select a clipping rectangle in the image display area of the controller by clicking.

The clipped area of the subject appears in the image display area of the live screen.

2 In the image display area of the controller, drag the clipping rectangle in the direction you want to pan/tilt.

The clipped area moves in the corresponding direction.

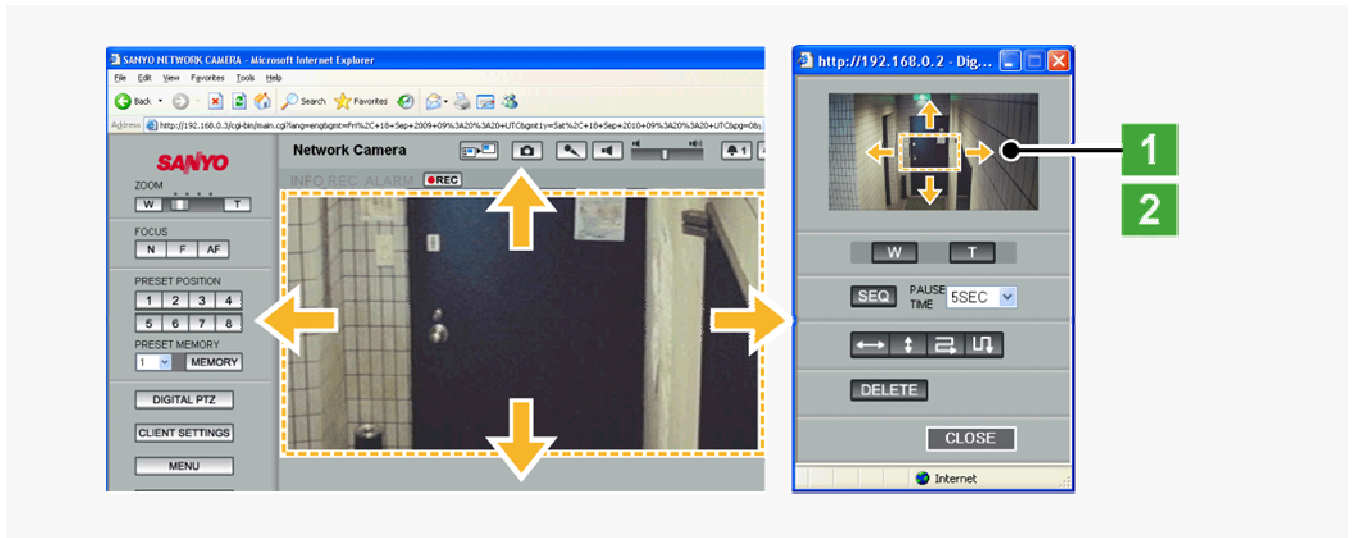

You may use the zoom function in conjunction with the manual panning/tilting function.

Selecting Live Stream and Streaming Protocol for Each User (CLIENT SETTINGS)

Click **CLIENT SETTINGS** on the control panel to display the CLIENT SETTINGS screen.

On this screen, you can perform the following operations:

- A Configuring the video stream displayed on the live screen
- B Configuring the audio
- C Changing your password



Some administrator configuration screen settings may limit the operations you can perform on this screen.

A Configuring the video stream displayed on the live screen

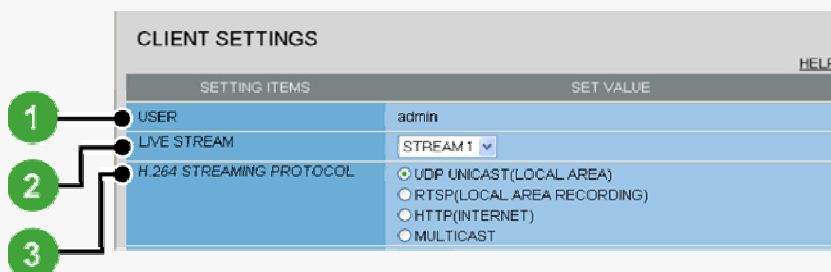

1 USER

Shows the name of the user currently accessing the camera.

2 LIVE STREAM

Select the stream you want to display on the live screen.

► **STREAM1, STREAM2, STREAM3, STREAM4**



The pull-down menu shows a list of permitted streams that are configured in [LIVE STREAM] on the USER REGISTRATION screen (administrator configuration screen).

This item will not be shown if [ACCESS LEVEL] is set to “admin” on the USER REGISTRATION screen.

You need to configure in advance the video conditions for each stream on the VIDEO & AUDIO SETTINGS screen (administrator configuration screen).

3 H.264 STREAMING PROTOCOL

Select the H.264 video streaming method (protocol).

► **UDP UNICAST (LOCAL AREA)**

► **RTSP (LOCAL AREA RECORDING)**

► **HTTP (INTERNET)**

► **MULTICAST**

Click **SET** to save the settings. To close the screen without saving the settings, click **CLOSE**.

B Configuring the audio

This camera supports bidirectional audio communications, so you can send and receive audio between the camera and your PC.

Hearing sounds from camera

Sending audio messages to camera



To perform bidirectional audio communications, for both the camera and your PC, you must connect a microphone to the audio input jack and a speaker system to the audio output jack.

To hear the sounds from the camera, your PC needs a sound card installed.



You need to configure in advance the audio settings on the VIDEO & AUDIO SETTINGS screen (administrator configuration screen).

Hearing sounds from camera

1 Click **CLIENT SETTINGS** on the control panel.

The CLIENT SETTINGS screen appears.

2 In [AUDIO (CAMERA TO PC)], select “ON”, select the [DEFAULT ON] check box, and click **SET**.

This causes the client PC to start up with the audio output capability enabled when connected to the camera, so that the user can hear sounds from the camera.

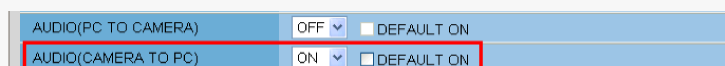

Setting to “OFF” causes the Receive Audio button and the volume control to disappear from the tool panel.

3 Use the tool panel controls.

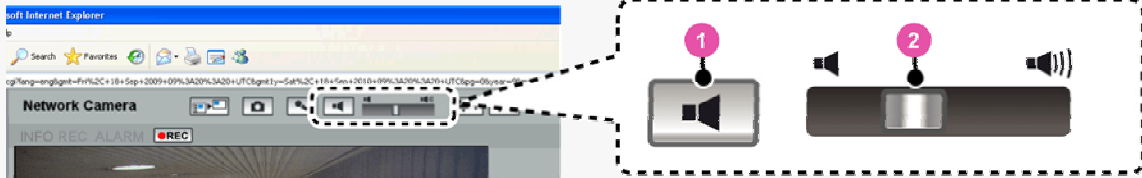

1 Receive Audio button



: Reception of audio enabled



: Reception of audio disabled

2 Volume control

Use this slider knob to control the audio output volume.

Sending audio messages to camera

From your PC, you can send audio alerts to suspicious people or communicate with people at the camera.



Required operation privilege: admin, operator1, operator2

Only a single user per camera may send audio messages at a time. If two or more users send audio simultaneously, the user who sends last will take precedence.

1 Click **CLIENT SETTINGS** on the control panel.

The CLIENT SETTINGS screen appears.

2 Set **[AUDIO (PC TO CAMERA)]** to “ON”, select the **[DEFAULT ON]** check box, and click **SET**.

This sets the client PC to always enable the audio transmission capability when connected to the camera so that the user can send audio messages to the camera.

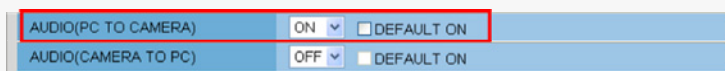

Setting **[AUDIO (PC TO CAMERA)]** to “OFF” causes the Send Audio button to disappear from the tool panel.

3 Click the Send Audio button on the tool panel to send audio messages to the camera.

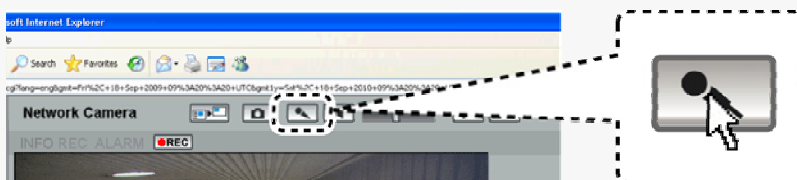

: Sending of audio enabled



: Sending of audio disabled

C Changing your password

You can change your own password.

PASSWORD CHANGE
CONFIRM PASSWORD

1 In the [PASSWORD CHANGE] field, type a new password.

You can type 4 to 32 alphanumeric characters.

2 In the [CONFIRM PASSWORD] field, type the same password again for confirmation and click **SET**.



These items will not be shown if [PASSWORD SET] is set to “admin” on the USER REGISTRATION screen.



Update your password periodically for security reasons.

Displaying Configuration Menu (MENU)

Click **MENU** on the control panel to display the configuration menu that includes a series of menu selection buttons.

Clicking one of these menu selection buttons displays the corresponding configuration screen.

If you are a surveillance system administrator, use these buttons to configure necessary settings according to the installation environment and application of your camera.



Required operation privilege: admin, operator1 (“admin” only for NETWORK SETTINGS screen)
 Without the required operation privilege, you will be presented with an authentication check dialog box when you click **MENU** on the live screen. In this case, you cannot access the menu selection buttons until you enter an adequate user name and password.

Menu Selection Buttons

	Button	Configuration Screen (Menu)	Operation
1	NETWORK	NETWORK SETTINGS	Configure the network settings of the camera.
2	CLOCK	CLOCK SETTINGS	Configure the clock date/time, daylight saving mode, automatic clock adjustment, and other settings.
3	USER	USER REGISTRATION	Register new login users, or change or delete existing user data.
4	VIDEO/AUDIO	VIDEO & AUDIO SETTINGS	Configure the video and audio conditions.
5	CAMERA	CAMERA SETTINGS	Configure the monitoring conditions and other settings according to the installation environment of the camera.
6	ALARM	ALARM SETTINGS	Configure the alarm input/output settings and the motion sensor function.
7	RECORDING	RECORDING	Configure the recording conditions of the camera.
8	SD/HDD	SD/HDD	Format the SD memory card or external hard disk.
9	E-MAIL	E-MAIL SETTINGS	Configure the alarm notification e-mail function and other automatic transmission settings.
10	FTP	FTP SETTINGS	Configure the image streaming conditions if you intend to record images from the camera to an FTP server.
11	SECURITY	SECURITY SETTINGS	Configure the security settings for permitting or rejecting the access to the camera from up to 10 PCs.
12	SCHEDULE	SCHEDULE SETTINGS	Configure the time period during which recording with the camera is activated.
13	OPTION	OPTION SETTINGS	Perform operations such as updating the firmware, restoring the factory defaults, and backing up and uploading settings.

Other Buttons

	Operation Buttons	Function
1	HELP	Provides an explanation of each function.
2	LIVE	Closes the configuration screen and returns to the live screen.

Language Selection (LANGUAGE)

Click **LANGUAGE** on the control panel to display the language selection screen.





► English, French, German, Spanish, Japanese



When the language selection screen appears, select the desired language within 10 seconds. Otherwise, you will be brought back to the live screen with the previous language setting.

Image Size Adjustment Panel (DISPLAY)

Click **DISPLAY** on the control panel to bring up the display control panel.

- ▶ : Panel is minimized. Clicking the button opens the panel.
- ▶ : Clicking the button closes the panel.



SIZE

The available options vary depending on your selections in [ASPECT RATIO] and [CODEC].

- ▶ **JPEG (16:9):** 1920×1080, 1280×720, 1024×576, 640×360
- ▶ **JPEG (4:3):** 2288×1712, 1600×1200, 1280×960, 1024×768, 800×600, 640×480, 320×240
- ▶ **H.264 (16:9):** 1920×1080, 1280×720, 640×360, 320×180
- ▶ **H.264 (4:3):** 1600×1200, 1280×960, 1024×768, 640×480, 320×240

Tool panel

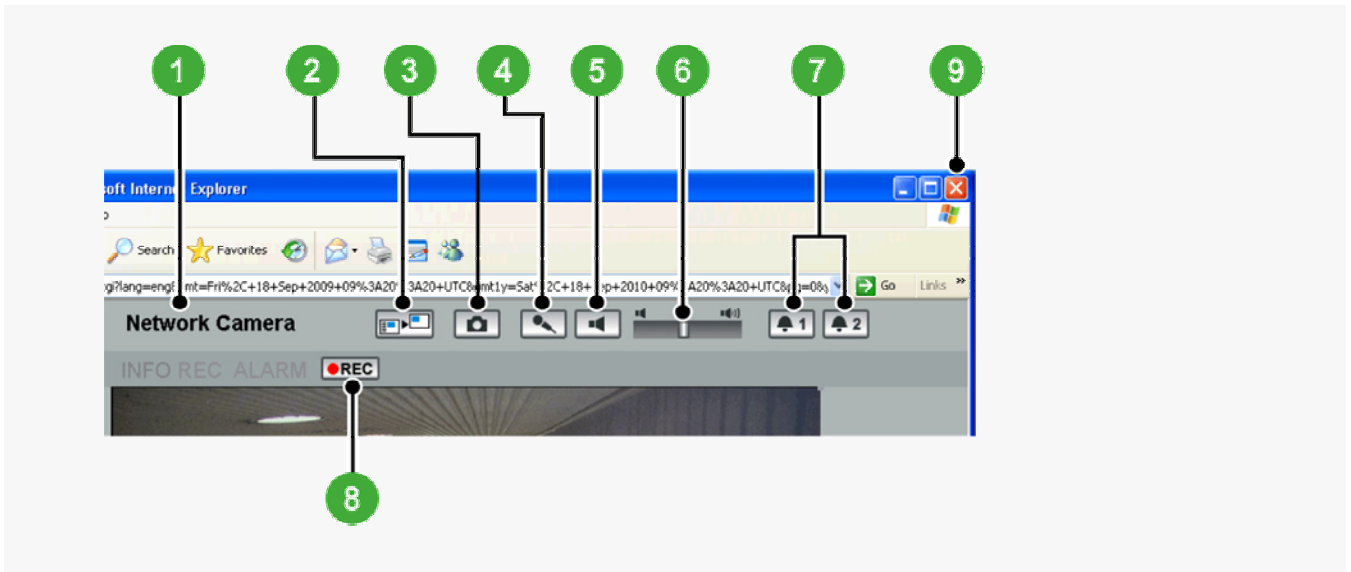

1 Camera Title

Shows the camera title you configured in [TITLE] on the CLOCK SETTINGS screen. The default camera title is "Network Camera".

The color of the camera title changes depending on the alarm state as follows:

- Black: Normal state
- Red: Alarm condition is being detected.



When the camera title is shown in red, no other alarm signal will be received.

2 Full Screen Button ()

Click this button to hide the control panel and the tool panel, and enlarge the video display to the maximum display area of the screen.

Clicking the button again restores the normal screen.

3 Capture Button ()

Click this button to capture the desired scene of the JPEG live streaming as a still image in a separate window. You can then save and print the captured image.

For details, refer to the "Printing and Saving a Still Image" section.

4 Send Audio Button ()

Click this button to send audio messages from the PC to camera.

For details, refer to the "Configuring audio" section.



Required operation privilege: admin, operator1, operator2

5 Receive Audio Button ()

Click this button to receive sounds from the camera to your PC.

For details, refer to the "Configuring audio" section.

6 Volume Control ()

Use this slider knob to control the audio output volume.

For details, refer to the “Configuring audio” section.

7 Remote Alarm Buttons (🔔 1 🔔 2)

You can use these buttons to output an alarm signal from the camera.
For details, refer to the “Sending a Remote Alarm Signal” section.

8 Emergency recording button (🔴 REC)

Click the button if you find any suspicious person or entity during monitoring to record the video on the camera.
For details, refer to “Manually Recording Surveillance Video”.

9 Close Button (❌)

Click this button to disconnect your PC from the camera and close the browser window.

Printing and Saving a Still Image

You can capture and then save or print the desired scene of the JPEG live streaming during monitoring.

1 Click the Capture button on the tool panel.

The captured still image appears in a separate window.



JPEG images can also be printed/saved while H.264 images are being displayed.

When a captured still image is shown, the live screen continues to display moving images in the video display area.

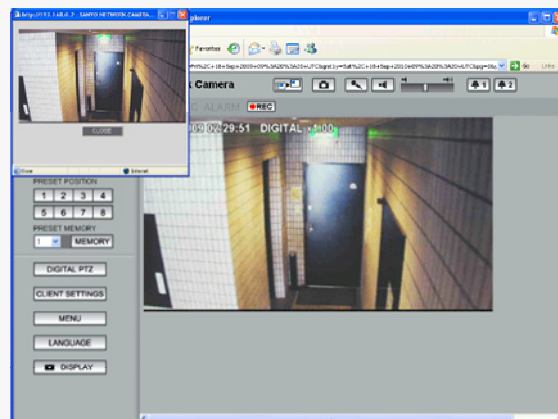

2 Right-click on the captured still image and, in the context menu, select the command (Save Picture As/Print Picture).

In the dialog box that opens, specify the printing/saving conditions and then execute the command.

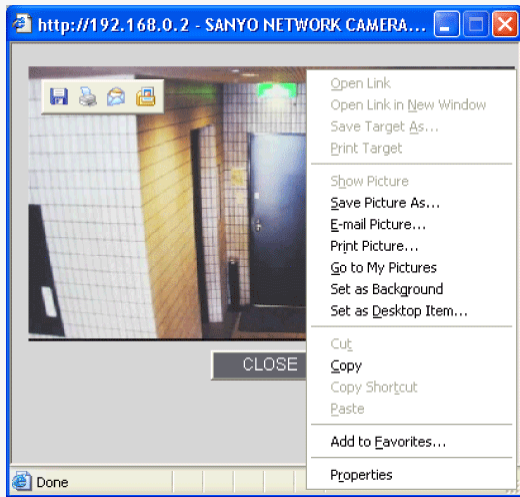

3 Click **Close** .

The window showing the captured still image closes.

Sending a Remote Alarm Signal

Use the Remote Alarm buttons provided on the live screen to send alarm signals from the camera's alarm output terminals.



Required operation privilege: admin, operator1, operator2



To use the remote alarm buttons, you must set in advance [ALARM OUT] to "REMOTE" and [ALARM OUT TIME] to the desired duration on the ALARM SETTINGS screen (administrator configuration menu).

1 Starting alarm signal output

Click one of the remote alarm buttons (shown in gray). The button turns orange and an alarm signal is output from the corresponding terminal.

If the camera is connected to a buzzer or other external device, you will hear an alarm sound from that device.



▶ **A** : Click this to send an alarm signal from the ALARM OUT1 terminal.

▶ **B** : Click this to send an alarm signal from the ALARM OUT2 terminal.

2 Stopping alarm signal output

The way you stop alarm signal output differs depending on the [ALARM OUT TIME] setting on the ALARM SETTINGS screen.

Automatic Stop

The automatic stop method is applied if you have specified an alarm output duration in [ALARM OUT TIME]. When the configured output time elapses, the alarm output automatically stops and the button returns to gray.

Manual Stop

The manual stop method is applied if you have selected “CC” in [ALARM OUT TIME].
Click the remote alarm button (orange) to stop the alarm output. The button returns to grey.

Manually Recording Surveillance Video

Video currently under surveillance can be recorded by operating the emergency recording button on the live screen.



Required operation privilege: admin, operator1, operator2



When using the emergency recording button, configure in advance the [REC BUTTON] on the RECORDING screen (administrator menu) to “ON” and the DURATION (recording time).

1 Starting Recording

Click the emergency recording button (grey). Recording begins and the button changes to orange.

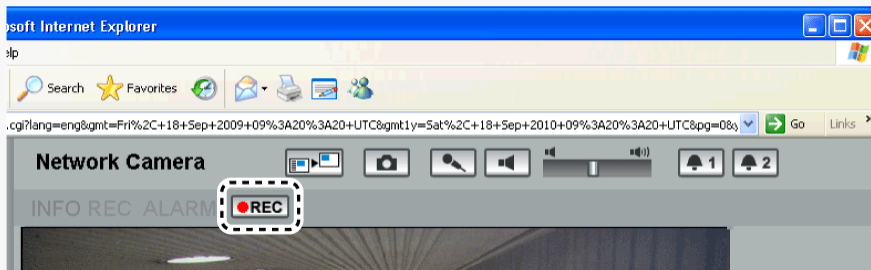

2 Stopping Recording

The method of stopping varies according to the configuration of [DURATION] under [REC BUTTON] on the RECORDING screen.

Automatic Stop

This is available in the case where recording time is configured in [DURATION].
When the configured recording time elapses, recording automatically stops and the button returns to grey.

Manual Stop

This is available in the case where [DURATION] is configured to “MANUAL”.
Click the emergency recording button (orange) to stop recording. The button returns to grey.

Information bar

When an error, warning or alarm, etc. occurs, the corresponding status is displayed in red.

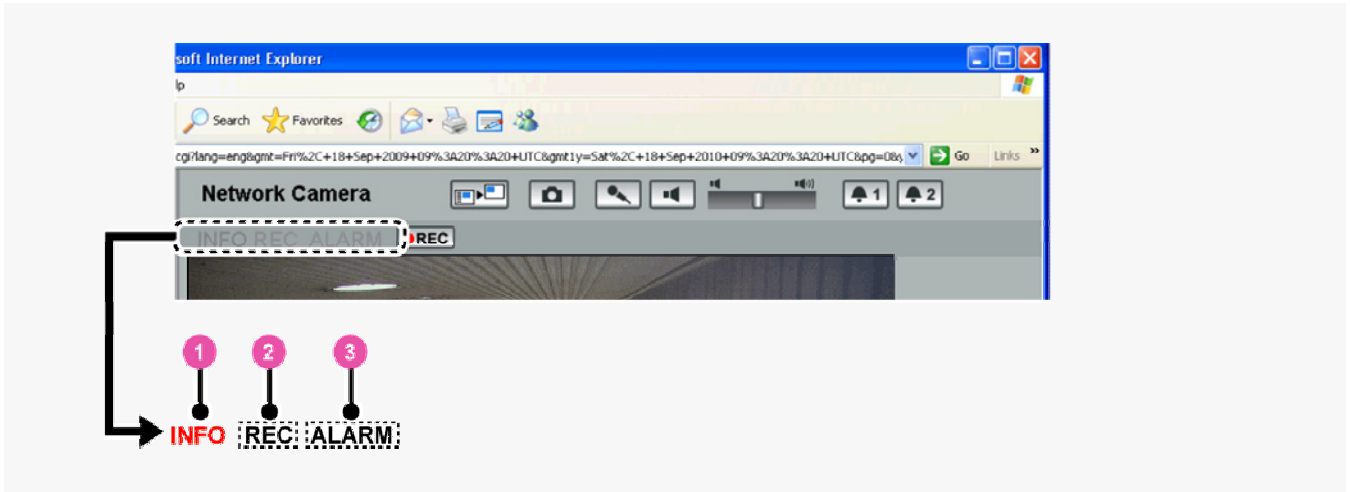

1 **INFO**: Appears when an error or warning occurs.

Clicking the indicator label causes system information to appear in a separate window.



The INFO status indicator appears in orange until either of the following conditions is met:

- In case of an error: The error condition is resolved.
- In case of a warning: The [SYSTEM INFORMATION] window opens.

2 **REC**: Recording in progress

3 **ALARM**: An alarm signal received



VCC-HD4600/HD4600P

Chapter 5

Working with Administrator Configuration Screens

NETWORK SETTINGS
CLOCK SETTINGS
USER REGISTRATION
VIDEO & AUDIO SETTINGS
CAMERA SETTINGS
ALARM SETTINGS
RECORDING
SD/HDD
E-MAIL SETTINGS
FTP SETTINGS
SECURITY SETTINGS
SCHEDULE SETTINGS
OPTION SETTINGS

NETWORK SETTINGS

Click **NETWORK** in the configuration menu to display the NETWORK SETTINGS screen.

On this screen, configure the following settings as required.

- A** Configuring basic network settings (NETWORK)
- B** Configuring DDNS setting (DDNS)
- C** Configuring HTTP settings
- D** Configuring RTSP/RTP settings
- E** Configuring access name settings (ACCESS NAME)
- F** Multicast settings (MULTICAST)



Required operation privilege: admin

Before attempting to configure these network settings, contact your network administrator.

A Configuring Basic Network Settings

Configure the environment required to connect to the camera via the network by specifying the IP address, subnet mask, and other information.

Manual Configuration

NETWORK SETTINGS	
NETWORK	
SETTING ITEMS	SET VALUE
IP ADDRESS	FIX 192 168 0 2
SUBNET MASK	255 255 255 0
GATEWAY	192 168 0 1
MAC ADDRESS	08 - 00 - 7B - 81 - 29 - 7E
DNS	FIX
DNS(PRIMARY)	192 168 0 1
DNS(SECONDARY)	0 0 0 0

SET CANCEL DEFAULT

1 In [IP ADDRESS], select “FIX” and type the IP address of the camera below it.

2 In [SUBNET MASK] and [GATEWAY], type your subnet mask and gateway addresses, respectively.

3 In [DNS (PRIMARY)] and [DNS (SECONDARY)], type your primary and secondary DNS server addresses and click **SET**.

Because you selected “FIX” in [IP ADDRESS], you specify here fixed DNS server addresses.

After completing the above steps, click the Close button to once disconnect and then reconnect to the camera to apply the changes.



To redo the procedure from the beginning, before clicking **SET**, click **CANCEL**.

To restore the factory default settings, click **DEFAULT**.

In [MAC ADDRESS], the MAC address of the camera is shown. You cannot change this address.

Automatic Configuration

The screenshot shows the 'NETWORK SETTINGS' window. It has a 'NETWORK' header and a 'HELP' link. Below is a table with 'SETTING ITEMS' and 'SET VALUE' columns. The 'DHCP' dropdown is selected. The IP address is 192.168.0.2, subnet mask is 255.255.255.0, and gateway is 192.168.0.1. The MAC address is 08-00-7B-81-29-7E. The 'DNS' dropdown is set to 'AUTO'. Below the table are 'SET', 'CANCEL', and 'DEFAULT' buttons. Three numbered callouts (1, 2, 3) point to the DHCP dropdown, the DNS dropdown, and the DNS(PRIMARY) field respectively.

SETTING ITEMS	SET VALUE
IP ADDRESS	DHCP
SUBNET MASK	192 . 168 . 0 . 2
GATEWAY	255 . 255 . 255 . 0
MAC ADDRESS	192 . 168 . 0 . 1
DNS	08 - 00 - 7B - 81 - 29 - 7E
DNS(PRIMARY)	AUTO
DNS(SECONDARY)	192 . 168 . 0 . 1
	0 . 0 . 0 . 0

1 In [IP ADDRESS], select “DHCP”.

The IP address, subnet mask, and gateway fields are automatically filled.

2 In [DNS], specify how you want to configure the DNS server addresses.

- ▶ **FIX:** In [DNS (PRIMARY)] and [DNS (SECONDARY)] (3), type your primary and secondary DNS server addresses and click **SET**.
- ▶ **AUTO:** Just click **SET**. Then, the system sets appropriate DNS server addresses automatically.

After completing the above steps, click the Close button to once disconnect and then reconnect to the camera to apply the changes.

B Configuring DDNS Settings

Using SANYO's DDNS service, you can connect to the camera from your Internet Explorer by simply entering the registered domain name, instead of the IP address of the camera.



To use the DDNS service, configure the following settings.

- Specify your DNS server address under [DNS SETTINGS] on this screen.
- Configure the port forwarding on your router. (For details, refer to your router's instruction manual.)

The screenshot shows the 'DDNS' configuration window. It has a 'DDNS' header and a 'HELP' link. Below is a table with 'SETTING ITEMS' and 'SET VALUE' columns. The 'DDNS' dropdown is set to 'ON'. The 'REGISTER' button is highlighted with a dashed box and a callout '3'. The 'DOMAIN NAME' field contains '.user.ddns-sanyosecurity.com'. The 'DDNS SERVER NAME' is 'members.ddns-sanyosecurity.com'. The 'USER NAME' is '08-00-7B-81-29-7E' and the 'PASSWORD' is 'UZAV-XIGM-INMJ'. The 'INTERVAL TIME' is '10MIN'. Below the table are 'SET', 'CANCEL', and 'DEFAULT' buttons. Four numbered callouts (1, 2, 3, 4) point to the DDNS dropdown, the USER NAME and PASSWORD fields, the REGISTER button, and the DOMAIN NAME field respectively.

SETTING ITEMS	SET VALUE
DDNS	ON
DOMAIN NAME	.user.ddns-sanyosecurity.com
DDNS SERVER NAME	members.ddns-sanyosecurity.com
USER NAME	08-00-7B-81-29-7E
PASSWORD	UZAV-XIGM-INMJ
INTERVAL TIME	10MIN
LOG	

1 In [DDNS], select “ON”.

The [REGISTER] button (3) appears. The [USER NAME] and [PASSWORD] fields (2) show the automatically assigned user name and password, respectively.

2 Write down the user name and password shown in the [USER NAME] and [PASSWORD] fields.

This information is required to register your domain name.

3 Click **REGISTER** to access the SANYO DDNS service site and register your domain name.

Follow the steps below to register your domain name.

1 On the LOG IN screen, enter the user name and password you wrote down and click **Login**.
The Domain Name registration/change screen appears.

SANYO SANYO Electric Co., Ltd. > SANYO TOP

LOG IN -SANYO DDNS Service-

Sanyo DDNS service is for users of Network System products of Sanyo Electric Co., Ltd.
This service will be provided after confirmation of purchase.
For your registration, please refer to the instruction manual enclosed in your purchase, or follow instructions from your dealer.
Please note that this service is only for registered customers.

Member Log in

User ID

Password

Log in

*JavaScript is used on this web site. Please activate JavaScript in browser settings.

Copyright(C) SANYO Electric Co., Ltd. All Rights Reserved. [Site policy](#)



SANYO DDNS service site URL:
<https://www.ddns-sanyosecurity.com>

2 Enter the domain name you want to use and click **Submit**.
The domain name is registered with the DDNS server.

SANYO SANYO Electric Co., Ltd. > SANYO TOP

Domain Name registration/change -SANYO DDNS Service-

Use of this service

1. Domain may consist of a-z,0-9 and hyphen. However, only a-z can be used for the first character.
2. Minimum of 32 characters in length for domain.
3. If any terms and conditions in below to confirm, SANYO has the right to suspend or terminate your account and the service when;
(a) user didn't use the registered domain for more than one month,
(b) outrage against public policy or infringement of third party rights in use were suspected,
(c) serious damage was occurred.
Without limiting the foregoing, SANYO considered it necessary.

Domain Name 00-02-69-00-B3-62

http:// test-sanyo .user.ddns-sanyosecurity.com

Submit

Copyright(C) SANYO Electric Co., Ltd. All Rights Reserved.

- 4** Return to the **NETWORK SETTINGS** screen ([DDNS]) and, in [DOMAIN NAME], type the domain name you just registered before “.user.ddns-sanyosecurity.com”. Then, click **SET**.



The [DDNS SERVER NAME] field is automatically filled (“members.ddns-sanyosecurity.com”), so you do not need to type it.

The [INTERVAL TIME] setting (access interval to the server) is fixed to “10MIN”.

In the [LOG] field, the DDNS update history log (one entry) is shown.

C Configuring HTTP settings

HTTP	
SETTING ITEMS	SET VALUE
HTTP PORT	80
SSL	OFF
SSL PORT NUMBER	443

SET **CANCEL** **DEFAULT**

- 1** In [HTTP PORT], type your HTTP port number.

Type a number between 1 and 65535.



The default port number depends on whether or not you enable SSL communication in [SSL].

- When [SSL] is set to “OFF”: 80
- When [SSL] is set to “ON”: 443

- 2** To use SSL communication, select “ON” in [SSL], type your SSL port number in [SSL PORT NUMBER], and click **SET**.

Using SSL communication enables the encryption of image transmission.



SSL communication is effective for JPEG streaming images only.

When SSL communication is enabled, you will be presented with a security warning dialog box when attempting to access the camera. However, this is not a problem and you can continue the operation by clicking [Yes].

If the message “This page contains both secure and nonsecure items...” appears, follow the steps below to erase it.

- 1 In Internet Explorer, click [Internet Options] in the [Tool] menu.
- 2 On the [Security] tab, click the [Custom Level...] button.
- 3 In the [Security Settings] dialog box, in the [Settings] section, select the “Display mixed content” radio button.

When SSL communication is enabled, the frame rate of the live streaming images may become slower depending on the resolution setting.

D Configuring RTSP/RTP settings

In [RTSP PORT], [RTP PORT (VIDEO)], and [RTP PORT (AUDIO)], type the desired port numbers and click **SET**.

RTSP/RTSP	
SETTING ITEMS	SET VALUE
RTSP PORT	554
RTP PORT(VIDEO)	5556
RTP PORT(AUDIO)	5558

SET CANCEL DEFAULT



The RTSP port number must be 554 or otherwise a number in the range of 1 to 65535.

The RTP port (video and audio) numbers must be even numbers in the range of 1026 to 65534 (except for numbers between 3874 and 5000, between 9874 and 10000, between 38087 and 38214, and between 49026 and 49152).

E Configuring Access Name Settings

If you intend to access the camera from video viewer or similar software, you may name each stream (access name) as you like for easy identification.

- 1 Under [ACCESS NAME (JPEG)], type an access name for each JPEG stream and click **SET**.

These settings are used for each stream for which you set the codec to "JPEG" on the VIDEO & AUDIO SETTINGS screen.

An access name must be specified for each stream (up to 32 alphanumeric characters).

ACCESS NAME	
SETTING ITEMS	SET VALUE
ACCESS NAME(JPEG)	
STREAM 1	Videolnput1/jpeg/1
STREAM 2	Videolnput1/jpeg/2
STREAM 3	Videolnput1/jpeg/3
STREAM 4	Videolnput1/jpeg/4

SET CANCEL DEFAULT

- 2 Under [ACCESS NAME (H.264)], type an access name for each H.264 stream and click **SET**.

These settings are used for each stream for which you set the codec to "H.264" on the VIDEO & AUDIO SETTINGS screen.

An access name must be specified for each stream (up to 32 alphanumeric characters).

STREAMING(H.264 & AUDIO)	
SETTING ITEMS	SET VALUE
ACCESS NAME(H.264)	
STREAM 1	Videolnput1/h264/1
STREAM 2	Videolnput1/h264/2
STREAM 3	Videolnput1/h264/3
STREAM 4	Videolnput1/h264/4

SET CANCEL DEFAULT

F Configuring Multicast settings

To enable multicast streaming, configure the multicast address, port numbers, and TTL settings for each stream and click **SET**.

MULTICAST(STREAM 1)

SETTING ITEMS	SET VALUE
MULTICAST ADDRESS	239 . 0 . 0 . 0
MULTICAST RTP PORT(VIDEO)	0
MULTICAST RTP PORT(AUDIO)	0
MULTICAST TTL	0

SET CANCEL DEFAULT



The multicast RTP port (video and audio) numbers must be even numbers in the range of 1026 to 65534 that do not overlap with the unicast RTP port numbers (except for numbers between 4000 and 5000, 10000, 10001, 38214, and 49152.)

The multicast TTL must be specified in the range of 1 to 255.

CLOCK SETTINGS

Click **CLOCK** in the configuration menu to display the CLOCK SETTINGS screen.

Before you start network operation, you need to configure the clock settings on this screen.

- A** Configuring camera title
- B** Configuring clock date/time and display style
- C** Configuring time zone and daylight saving mode
- D** Configuring automatic clock adjustment



Required operation privilege: admin, operator1

A Configuring camera title

Configure the camera title that will be displayed on the live screen and in e-mails, image files, and so on.

SETTING ITEMS	SET VALUE
TITLE	Network Camera

In [TITLE], type the desired camera title and click **SET**.

You can type up to 16 alphanumeric characters.

The setting is saved and the camera title appears on the live screen.



Note that the camera title cannot include the following symbols: double quote ("), single quote ('), ampersand (&), greater-than sign (>), percent (%), backslash (\), less-than sign (<), vertical bar (|), and semicolon (;).

A warning dialog box will appear when you click **SET** if the camera title includes any invalid character.

B Configuring clock date/time and display style

1	CLOCK SET	DATE	2009 / JAN / 01 THU
		TIME	00 : 00 AM
		12/24	24 HRS
2	CLOCK DISPLAY	SIZE	MEDIUM
		POSITION	UP LEFT
3	DATE/TIME FORMAT		D/M/Y

1 In [CLOCK SET], configure the current date and time in [DATE] and [TIME], respectively.

The configured date and time settings will be reflected on the camera's built-in clock.

The day of the week is automatically set based on the date and time settings.

2 In [CLOCK DISPLAY], select the clock display style.

- 1** 12/24 (Clock type): 12HRS (12-hour clock), 24HRS (24-hour clock)
- 2** SIZE (Character size): SMALL, MEDIUM, LARGE
- 3** POSITION (Display position): UP LEFT, UP RIGHT, DOWN LEFT, DOWN RIGHT, OFF (Hidden)

3 In [DATE/TIME FORMAT], select the date/time display format and click **SET** .

▶ M/D/Y, Y/M/D, D/M/Y

C Configuring time zone and daylight saving mode

1	TIME ZONE	GMT Dublin, Edinburgh, Lisbon, London			
2	DAYLIGHT SAVING MODE (SUMMER TIME MODE)	USE			
	SETTING ITEMS	WEEK	MONTH	TIME	
3	ON	LST - SAT	MAR	01	: 00
	OFF	LST - SAT	OCT	01	: 00

1 In [TIME ZONE], select the region where the camera is used.

2 In [DAYLIGHT SAVING MODE], select whether or not to use the daylight saving mode.

Although an appropriate setting is automatically selected according to the [TIME ZONE] setting, you can change it manually.

▶ **NO USE:** Disables the daylight saving mode.

▶ **USE:** Enables the daylight saving mode.

3 In [DAYLIGHT SAVING], select when to start (in [ON]) and end (in [OFF]) the daylight saving mode and click **SET** .

Although an appropriate setting is automatically selected according to the [TIME ZONE] setting, you can change it manually.

D Configuring automatic clock adjustment

In [CLOCK ADJUST], select how you want to automatically adjust the camera's internal clock.

▶ **OFF:** Disables the clock adjustment function.

▶ **ON (NTP):** Enables automatic clock adjustment that retrieves the date and time information from the NTP server.

→ You need to configure the NTP settings.

▶ **LOGIN (PC):** Enables automatic clock adjustment that retrieves the date and time information from the PC when an admin user logs into it.

▶ **ALARM IN1:** Enables automatic clock adjustment that adjusts the clock to the specified time based on the signal received from the device connected to the ALARM IN1 terminal.

→ You need to configure the [CLOCK IN] setting.



It is recommended to select "ON (NTP)" when the camera is connected to the Internet.

If the camera is not connected to the Internet, select "LOGIN (PC)" or, using the supplied monitoring software "VA-SW3050Lite", enable the clock adjustment function (24-hour interval) in the clock setting.

Configuring NTP Settings

- 1 In [CLOCK ADJUST], select “ON (NTP)”.
- 2 Configure the required settings shown below and click **SET**.

SETTING ITEMS	SET VALUE
CLOCK ADJUST	ON(NTP)
TIME TO SYNCHRONIZE	00 : 00
REFRESH MANUALLY	REFRESH
NTP	
NTP SERVER ADDRESS	
LOG	

1 To automatically adjust the clock time every day, in [TIME TO SYNCHRONIZE], select the 24-hour time to which you want to adjust the clock (for example, “10:30”).

TIME TO SYNCHRONIZE	10 : 30
---------------------	---------

2 To adjust the clock to the current time, click **REFRESH**.

3 In [NTP SERVER ADDRESS], type the IP address or domain name of the NTP server from which you want to retrieve the date and time information.

4 In [LOG], the last entry of the operation log related to automatic clock adjustment is shown.



When “ON (NTP)” in [CLOCK ADJUST] is selected, the clock adjustment function adjusts the clock in the following timings.

- When the camera is turned on
- At the time selected in [TIME TO SYNCHRONIZE] (every day)
- When any change is made to the settings on this screen

To use a domain name, you must specify the DNS server address in [DNS SERVER ADDRESS] on the NETWORK SETTINGS screen.

Configuring CLOCK IN Setting

- 1 In [CLOCK ADJUST], select “ALARM IN1”.
- 2 In [CLOCK IN], select the 24-hour time to which you want to adjust the clock (for example, “22” for 10 p.m.) when the switch connected to the ALARM IN1 terminal turns on, and click **SET**.

SETTING ITEMS	SET VALUE
CLOCK ADJUST	ALARM IN1
TIME TO SYNCHRONIZE	00 : 00
REFRESH MANUALLY	REFRESH
NTP	
NTP SERVER ADDRESS	
LOG	
CLOCK IN	22



The clock time will not be adjusted if the difference between the set time and the current time exceeds the range of -29 to +30 minutes.

USER REGISTRATION

Click **USER** in the configuration menu to display the USER REGISTRATION screen.

On this screen, you can register new login users, or change or delete existing user data.

- A** Registering a new user (ADD)
- B** Changing existing user data (CHANGE)
- C** Deleting an existing user (DELETE)



Required operation privilege: admin, operator1

A Registering a New User

Besides the factory default users (admin, operator1, operator2, download, and guest), you can register up to 20 client users.

For a new user, you can assign the same name as an existing user.

- 1** Click **ADD**.

The USER REGISTRATION screen appears in a separate window.

The screenshot shows the USER REGISTRATION screen in two states. The top part shows a list of users with columns for USER NAME, PASSWORD, LIVE STREAM, ACCESS LEVEL, STREAM SET, and PASSWORD SET. A dashed box labeled 'B' highlights the 'ANONYMOUS USER LOG IN' pull-down menu and its 'SET' button. A dashed box labeled 'A' highlights the user list table. A dashed box labeled '1' highlights the 'ADD' button. An arrow points down to a second screenshot showing the detailed user registration form with fields for USER NAME, PASSWORD, CONFIRM PASSWORD, LIVE STREAM, ACCESS LEVEL, CLIENT SET, STREAM SET, and PASSWORD SET, along with 'SET' and 'CANCEL' buttons.

A User list

Displays the list of registered users.

This list initially shows the factory default users (admin, operator1, operator2, download, and guest).



For these factory default users, you can change the password only.

B [ANONYMOUS USER LOG IN] pull-down menu

Use this pull-down menu to enable/disable anonymous user login.

Selecting "ON" allows all users to log into the camera without authentication.



In this case, all login users are regarded as guest users. This means that users will be presented with an authentication check dialog box if they attempt to perform any operation beyond the guest user privilege and must enter an adequate user name and password to proceed.

2 In [USER NAME] and [PASSWORD], type your user name and password, respectively. Then, in [CONFIRM PASSWORD], type the same password again.

You can type 4 to 32 alphanumeric characters.

3 In [LIVE STREAM], select the check box next to the stream you want to allow this user to monitor.

You may select two or more check boxes.



You need to configure the video conditions for each stream on the VIDEO & AUDIO SETTINGS screen.

4 In [ACCESS LEVEL], select the operating privilege you want to grant to this user.

For details, see the “Operation Privileges” section.

5 In [CLIENT SET], select whether or not to allow the user to change the stream and password settings on the CLIENT SETTINGS screen, and click **SET**.

The settings are saved and the USER REGISTRATION screen closes.

The user list now includes the user you just registered.

In [STREAM SET], specify whether to allow the user to change the live stream setting.

- ▶ **admin:** Does not allow the user to change the live stream setting.
 - ➔ The stream specified in [LIVE STREAM] on this screen is applied.
- ▶ **user:** Allows the user to change the live stream setting.
 - ➔ The user can change the live stream setting on the CLIENT SETTINGS screen.

In [PASSWORD SET], specify whether to allow the user to change the password setting.

- ▶ **admin:** Does not allow the user to change the password setting.
 - ➔ The password specified in [PASSWORD] on this screen is applied.
- ▶ **user:** Allows the user to change the password setting.
 - ➔ The user can change the password setting on the CLIENT SETTINGS screen.

B Changing existing user data (CHANGE)

- 1 Select the check box next to the user whose data you want to change and click **CHANGE**.

The user registration screen for the selected user appears in a separate window.

USER REGISTRATION

ANONYMOUS USER LOG IN: OFF SET

USER NAME	PASSWORD	LIVE STREAM	ACCESS LEVEL	STREAM SET	PASSWORD SET
<input type="checkbox"/> admin	****	1/2	admin	admin	admin
<input type="checkbox"/> operator1	*****	1/2	operator1	admin	admin
<input type="checkbox"/> operator2	*****	1/2	operator2	admin	admin
<input type="checkbox"/> download	*****		download	admin	admin
<input type="checkbox"/> guest	****	1/2	guest	admin	admin
<input checked="" type="checkbox"/> SANYO001	*****	2	admin	admin	admin

ADD CHANGE DELETE

- 2 Change the desired settings and click **SET**.

Your changes are saved and reflected in the user list.

USER REGISTRATION

USER NAME: SANYO001

PASSWORD: SANYO001

CONFIRM PASSWORD: SANYO001

LIVE STREAM: stream1 stream2 stream3 stream4

ACCESS LEVEL: admin operator 1 operator2 guest

CLIENT SET: user

STREAM SET: user

PASSWORD SET: user

SET CANCEL

C Deleting an existing user (DELETE)

- Select the check box next to the user you want to delete and click **DELETE**.

The selected user is deleted from the user list.

USER REGISTRATION

ANONYMOUS USER LOG IN: OFF SET

USER NAME	PASSWORD	LIVE STREAM	ACCESS LEVEL	STREAM SET	PASSWORD SET
<input type="checkbox"/> admin	****	1/2	admin	admin	admin
<input type="checkbox"/> operator1	*****	1/2	operator1	admin	admin
<input type="checkbox"/> operator2	*****	1/2	operator2	admin	admin
<input type="checkbox"/> download	*****		download	admin	admin
<input type="checkbox"/> guest	****	1/2	guest	admin	admin
<input checked="" type="checkbox"/> SANYO001	*****	4	guest	user	user

ADD CHANGE DELETE



You cannot delete the factory default users (admin, operator1, operator2, download, and guest).

VIDEO & AUDIO SETTINGS

Click **VIDEO/AUDIO** in the configuration menu to display the VIDEO & AUDIO SETTINGS screen. On this screen, configure the conditions of each video stream and the audio you receive from the camera.

- A** Configuring Aspect Ratio and Recording (ASPECT RATIO/RECORDING)
- B** Configuring video (VIDEO)
- C** Configuring audio (AUDIO)
- D** Configuring TV output (TV OUT)



Required operation privilege: admin, operator1

A Configuring Aspect Ratio and Recording

This setting applies to all video/image streams you are configuring.

STREAM	NAME	RECORDING	CODEC	RESOLUTION	DIGITAL PTZ	G	
<input type="checkbox"/>	STREAM 1	STREAM1	---	H.264	1280x720	OFF	30
<input type="checkbox"/>	STREAM 2	STREAM2	---	JPEG	1280x720	OFF	30

1 Click a radio button under [ASPECT RATIO] to select the aspect ratio (width-to-height ratio) of the displayed image.

▶ 16:9 (Landscape), 4:3 (Portrait)

2 To record a video stream, configure [RECORDING] to “ON” and click **SET**.

If you configure to “OFF”, you can only view the video streams and cannot record them.



Clicking **SET** reboots the camera.

B Configuring Video

This camera supports multi-stream video transmission, allowing you to register up to four video/image streaming condition patterns.

Thus, you can reduce the load of the entire system by choosing optimal settings for your application, such as recording or live video monitoring.



When you have added, changed, or deleted registered information, be sure to click **SET** in the stream list. Otherwise, changes you made won't be saved and reflected in the stream settings.

Clicking **SET** reboots the camera.

Note that the number of registerable streams and configurable settings may be affected by other stream settings.

Registering a New Stream (ADD)

The camera provides two factory default stream patterns (STREAM1 and STREAM2). Besides these, you can register up to two custom stream patterns (STREAM3 and STREAM4).

1 Click **ADD**.

The stream registration screen appears in a separate window.

“STREAM3” will be automatically set for the first additional stream.

STREAM	NAME	RECORDING	CODEC	RESOLUTION	DIGITAL PTZ	GOP	FRAME RATE	STREAM UTILIZATION	PRIORITY	PICTURE QUALITY
STREAM 1	STREAM1	---	H.264	1280x720	OFF	30	30ips	36%	QUALITY	ENHANCED
STREAM 2	STREAM2	---	JPEG	1280x720	OFF	30	10ips	12%	QUALITY	ENHANCED



In the stream list (A), the currently registered streams are shown. Initially, this list shows video settings for STREAM1 and STREAM2.

2 Configure the video/image conditions for the stream you want to register and click **SET**.

The settings are saved. The stream list now includes the stream you just registered.

1 In [NAME], type the stream name you want.

You can type up to 64 alphanumeric characters.

2 In [RECORDING], select the recording type.

▶ OFF, NORMAL, ALARM, NORMAL/ALARM, NETWORK FAILURE



The configured contents are reflected in [RECORD STREAM] on the RECORDING screen. This cannot be configured if the recording configuration (A-2) at the top of the screen is set to “OFF”.

3 In [CODEC], select the image/video compression format.

▶ JPEG, H.264

4 In [RESOLUTION], select the display resolution.

The available options vary depending on your selections in [ASPECT RATIO] and [CODEC].

- ▶ **JPEG (16:9):** 1920×1080, 1280×720, 1024×576, 640×360
- ▶ **JPEG (4:3):** 2288×1712, 1600×1200, 1280×960, 1024×768, 800×600, 640×480, 320×240
- ▶ **H.264 (16:9):** 1920×1080, 1280×720, 640×360, 320×180
- ▶ **H.264 (4:3):** 1600×1200, 1280×960, 1024×768, 640×480, 320×240

5 In [DIGITAL PTZ], enable or disable the digital PTZ function.

To display areas of subject you clipped, or use the digital PTZ function on the live screen, select “ON”.



You cannot select “ON” if you selected “H.264” in [CODEC].

Selecting “ON” in [DIGITAL PTZ] fixes the [RESOLUTION] value to a VGA-equivalent size (“640×360” in 16:9 aspect ratio or “640×480” in 4:3 aspect ratio).

6 If you selected “H.264” in [CODEC], in [GOP], enter a GOP value.

This enables you to specify the GOP setting for the H.264 video stream.

7 In [FRAME RATE], select the frame rate of the stream.

The available options vary depending on your selection in [CODEC] and your camera model.

- ▶ **JPEG:** VCC-HD4600: 0.1ips, 0.2ips, 0.5ips, 1ips, 3ips, 5ips, 10ips, 15ips, 30ips
VCC-HD4600P: 0.1ips, 0.2ips, 0.5ips, 1ips, 2.5ips, 5ips, 8ips, 12.5ips, 25ips
- ▶ **H.264:** VCC-HD4600: 5ips, 10ips, 15ips, 30ips
VCC-HD4600P: 5ips, 8ips, 12.5ips, 25ips

8 In [PRIORITY], select whether you put priority on the video/image quality or the bit rate.

- ▶ QUALITY, BIT RATE

If you selected “QUALITY”, in [PICTURE QUALITY], specify the video/image quality.

Then, the system shows an appropriate bit rate depending on the selected quality.

- ▶ BASIC, NORMAL, ENHANCED, FINE, SUPER FINE

If you selected “BIT RATE”, in [BIT RATE], the system shows an appropriate bit rate for you.

Type the bit rate directly, if you want to change it.



The setting range is limited depending on the resolution and/or frame rate settings.

3 Click **SET in the stream list.**

The camera restarts, and the registered settings are applied.

Changing existing stream data (CHANGE)

You may also choose to change the factory-default stream settings (STREAM1 and STREAM2).

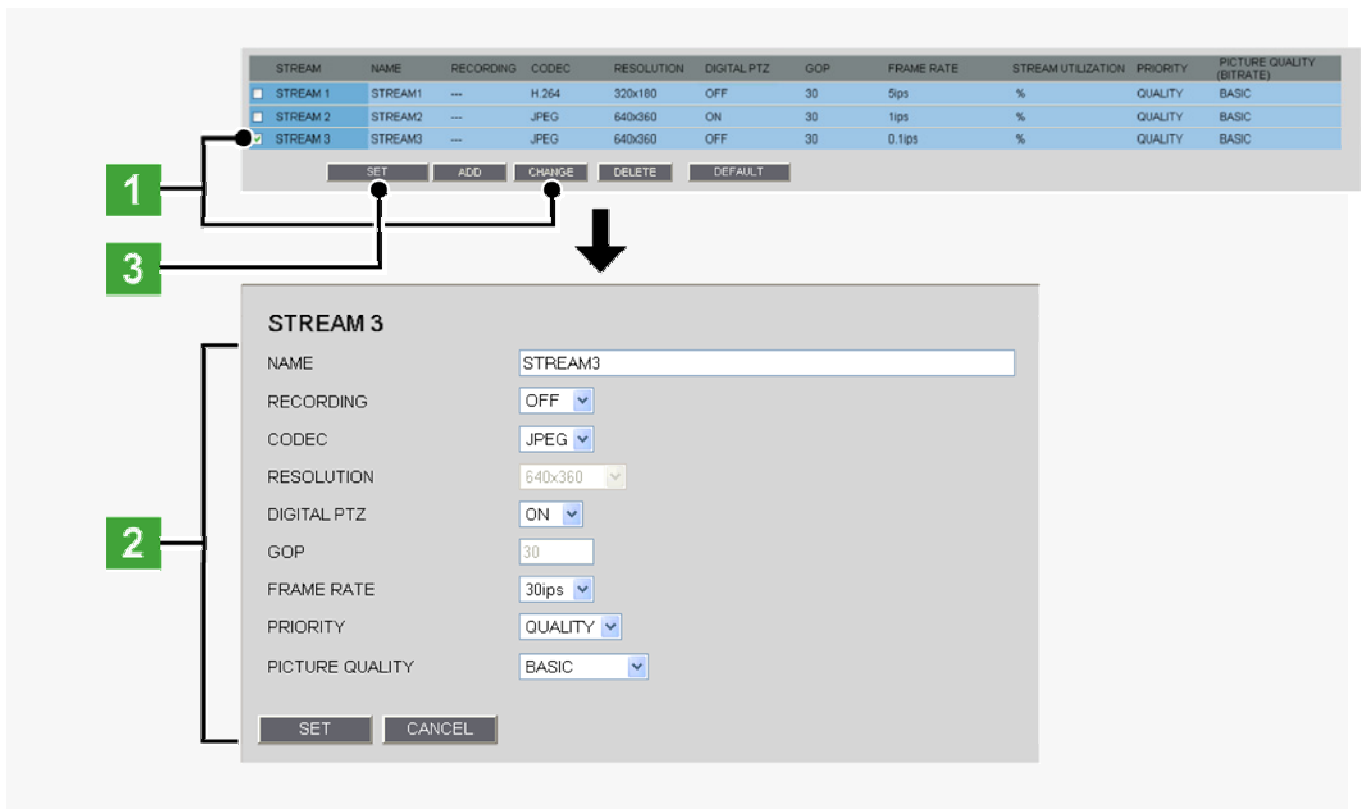

- 1 Select the check box next to the stream for which you want to change data and click **CHANGE** .

The stream registration screen for the selected stream appears in a separate window.

- 2 Change the desired settings and click **SET** .

Your changes are saved and reflected in the stream list.

- 3 Click **SET** in the stream list.

The camera restarts, and the changed settings are applied.

Deleting an existing stream (DELETE)

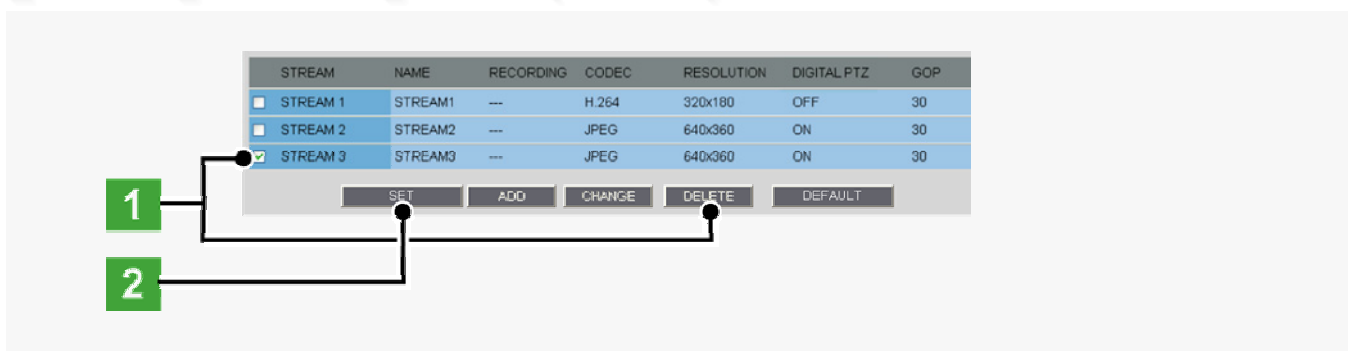

- 1 Select the check box next to the stream you want to delete and click **DELETE** .

The selected stream is deleted from the stream list.

- 2 Click **SET** in the stream list.

The camera restarts, and the stream you selected has been deleted.

C Configuring audio (AUDIO)

Configure the conditions of the audio you receive from the camera.

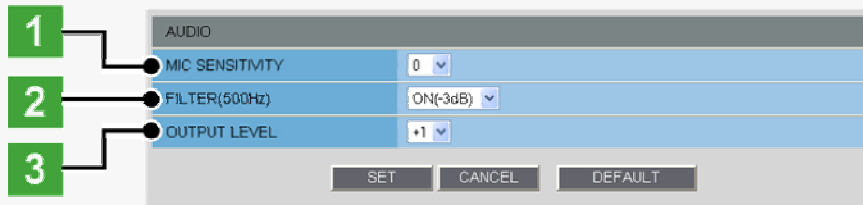

1 In [MIC SENSITIVITY], specify the microphone sensitivity.

Select the sensitivity of the microphone connected to the camera from 8 levels.

- ▶ +4, +3, +2, +1, 0, -1, -2, -3

2 In [FILTER(500Hz)], enable or disable the audio filter.

The audio filter reduces the 500 Hz or less frequency components of the audio.

A filter option with a lower negative dB value produces larger effects.

- ▶ ON(-3dB), ON(-6dB), OFF

3 In [OUTPUT LEVEL], select the desired audio output level and click **SET**.

Here, you specify the gain value of the audio output amplifier from the following 4 levels.

- ▶ +2, +1, 0, -1

D Configuring TV output (TV OUT)

Configure the video output terminal to use.



You cannot output video signal from the HDMI connector and the MONITOR OUT connector at the same time.

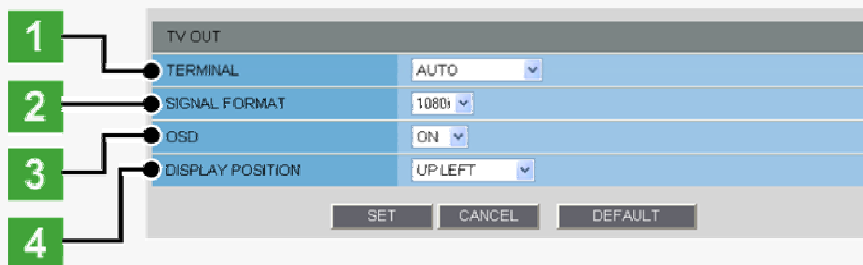

1 In [TERMINAL], select the video connector you want to use.

- ▶ AUTO: A connected connector is detected automatically.
- ▶ HDMI, MONITOR OUT



If both the HDMI and the MONITOR OUT connectors are connected in “AUTO” mode, the HDMI connector takes precedence.

2 In [SIGNAL FORMAT], select the video size.

- ▶ VCC-HD4600: 1080i, 720p, 480p
- ▶ VCC-HD4600P: 1080i, 720p, 576p



You can select [SIGNAL FORMAT] only when “HDMI” is set for [TERMINAL].

3 In [OSD], select either “ON” or “OFF” for the OSD display.

When set to “ON”, the zoom magnification will be displayed on the monitor.

4 In [DISPLAY POSITION], set the OSD display position, and then click **SET** .

▶ UP LEFT, UP RIGHT, DOWN LEFT, DOWN RIGHT

CAMERA SETTINGS

Click **CAMERA** button in the configuration menu to display the CAMERA SETTINGS screen.
The CAMERA SETTINGS screen includes a sub menu from which you can access 15 camera settings to configure the monitoring and other conditions of the camera.



Required operation privilege: admin, operator1

Function of Each Screen Component

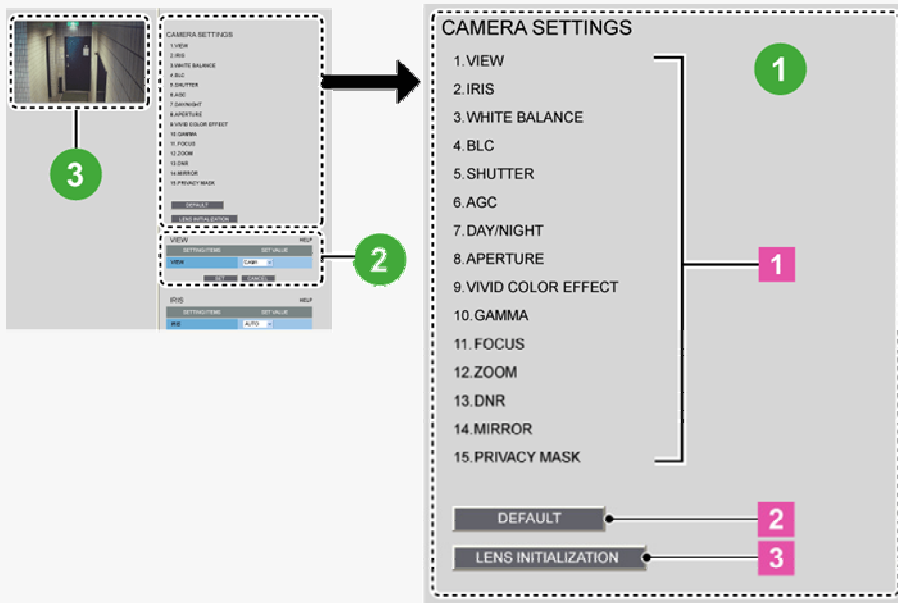

1 Sub Menu List

The CAMERA SETTINGS sub menu offers a list of camera settings.

- 1** Sub menu: Click one of the menu items in the sub menu to jump to the desired camera setting screen.
- 2** **DEFAULT** : Click this button to reset all the settings you configured for the selected view (CAM1/CAM2) to the defaults (factory settings).
- 3** **LENS INITIALIZATION** : Initialize the lens focus and zoom settings.

2 Configuration Section

This area shows a series of camera settings. You can use the vertical scroll bar and scroll buttons to scroll the settings up and down.

For each camera setting configuration section, the following buttons are provided.

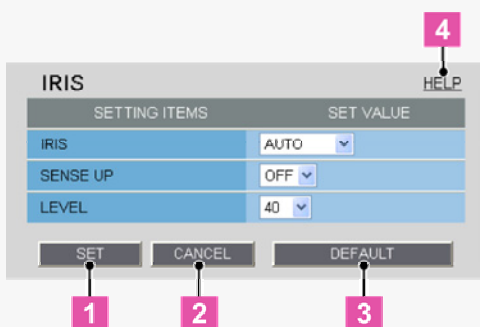

- 1 SET** : Click this button when finished configuring the camera settings you accessed by clicking each sub menu item.
- 2 CANCEL** : Click this button before clicking **SET** to restore the previous settings.
- 3 DEFAULT** : Click this button to reset the settings on the camera configuration screen to the defaults (factory settings).
- 4 HELP**: Click this to display a menu from which you can display the explanation of each configuration screen on the HELP screen.

Configuration Summary for Each Sub Menu Item

	Sub Menu	Operation	Application
1	VIEW	You can have two patterns of view settings (CAM1/CAM2) by configuring the monitoring conditions through sub menu items "2 IRIS" to "11 PRIVACY MASK".	VIEW
2	IRIS	Configure the lens iris.	VIEW
3	WHITE BALANCE	Adjust the white balance.	VIEW
4	BLC	Configure the backlight compensation function.	VIEW
5	SHUTTER	Configure the electronic shutter.	VIEW
6	AGC	Configure the gain of the video signal.	VIEW
7	DAY/NIGHT	Configure whether to use a fixed mode (color or black-and-white) or to automatically switch from the color mode (daytime) to black-and-white mode (nighttime) in order to increase sensitivity for darker images in night time.	VIEW
8	APERTURE	Corrects the profile of the target object.	VIEW
9	VIVID COLOR EFFECT	Increases the saturation of images.	VIEW
10	GAMMA	Adjusts the contrast and brightness level.	VIEW
11	FOCUS	Configure the lens focus settings.	Common
12	ZOOM	Configure the optical zoom speed, electronic zoom, and other zoom settings.	Common
13	DNR	Reduces automatically the image noise in low illuminance conditions.	VIEW
14	MIRROR	Inverts images vertically and horizontally.	Common
15	PRIVACY MASK	Configure the privacy mask settings to mask portions of the subject you want to hide for privacy protection.	Common



"Application" in the above table means the following:

VIEW: The configured settings will be applied to "CAM1" or "CAM2", whichever you selected under [VIEW].

Common: The configured settings will be applied commonly to "CAM1" and "CAM2" selected under [VIEW].

3 Live video

You can view how your changes affect the video image in real time.

VIEW

You can configure two patterns of monitoring conditions.

For example, select "CAM1" to configure the normal live monitoring conditions for daytime use and select "CAM2" to configure the monitoring conditions with the Day/Night function for nighttime use, respectively. Thus, you can switch the monitoring conditions depending on your needs.

SETTING ITEMS	SET VALUE
VIEW	CAM1

Buttons: SET, CANCEL, DEFAULT

Configuring Monitoring Conditions

In [VIEW], select “CAM1” or “CAM2” and then configure the monitoring conditions by clicking each menu item in the sub menu.

Switching between Monitoring Conditions

In [VIEW], select “CAM1” or “CAM2”. The monitoring conditions configured for the selected view setting are now applied to the camera.

IRIS

Configure the lens iris according to the luminance level of the target object.

AUTO: Selects the auto iris mode.

MANUAL: Selects the manual iris mode.



The configured settings will be applied to “CAM1” or “CAM2”, whichever you selected under [VIEW].

Configuring the Auto Iris Mode (AUTO)

Configuring these settings enables the camera to automatically adjust the lens iris to reproduce natural images even in outdoors where the luminance difference is significant, or under backlight conditions.

SETTING ITEMS	SET VALUE
IRIS	AUTO
SENSE UP	OFF
LEVEL	40

Buttons: SET, CANCEL, DEFAULT

1 In [IRIS], select “AUTO”.

2 In [SENSE UP], select the electronic sensitivity boosting power.

▶ OFF, x2, x4, x8, x16, x32



Enabling the electronic sensitivity boosting function causes the following:

The exposure time of the camera's image sensing device will be increased automatically in dark situations. This may result in conspicuous afterimages, blurs, and white spots if the subject includes any moving object.

If [DAY/NIGHT] is set to “AUTO”, the electronic sensitivity boosting function will work only for black/white video images.

The electronic iris (EI) setting will be cancelled.

[SHUTTER] is set to “OFF”, preventing you from configuring the electronic shutter setting (“SHORT” or “LONG”).

3 In [LEVEL], select the video signal level and click **SET** .

▶ 0 (dark) to 100 (bright)

Configuring the Manual Iris Mode (MANUAL)

The electronic iris (EI) function cannot be used in conjunction with the auto iris function.

If you have decided to use the electronic iris, configure the lens iris manually using the following procedure.

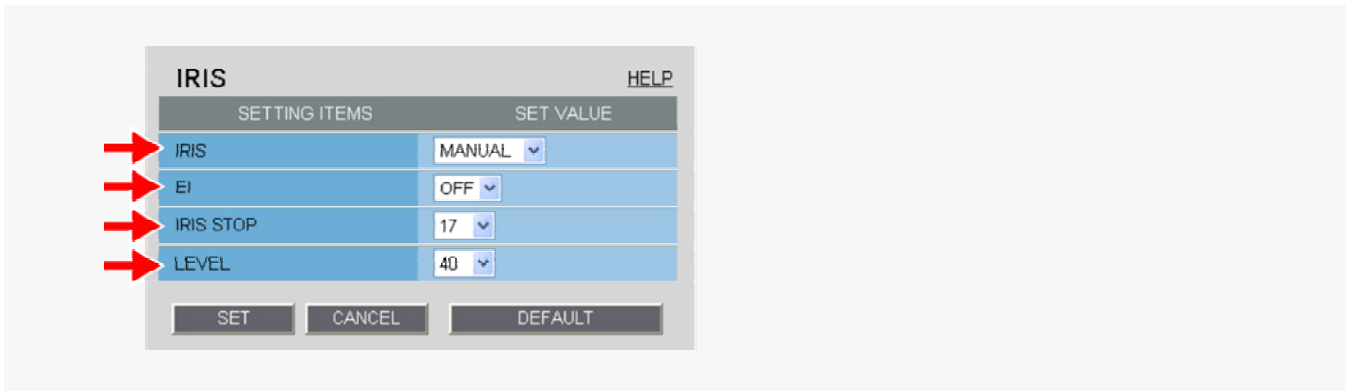

1 In [IRIS], select “MANUAL”.

2 In [EI], enable or disable the electronic iris.

Adjusts the exposure, controlling both the AGC circuit and the shutter speed.

- ▶ OFF: Disables the electronic iris.
- ▶ ON: Enables the electronic iris.



Enabling the electronic iris (EI) function causes the following:

The electronic shutter (SHUTTER) setting (“SHORT” or “LONG”) will be cancelled and the electronic sensitivity boosting (SENSE UP) function will not work.

Under extremely bright lighting, the electronic iris function cannot adjust the light entering the lens, resulting in a phenomenon such as a smear. This may be prevented by adjusting the lighting angle or other measures.

Under fluorescent lighting, the camera may cause the target image to flicker. To prevent this, replace the fluorescent lamps with incandescent lamps.

3 In [IRIS STOP], select the value to adjust the lens iris.

The lens iris opens or closes based on the iris stop setting.

- ▶ 1 (closes the iris = dark) to 17 (opens the iris = bright)

4 In [LEVEL], select the video signal level and click **SET** .

- ▶ 0 (dark) to 100 (bright)

WHITE BALANCE

Select and configure the white balance adjustment mode.

- ▶ **ATW:** Auto trace white balance
- ▶ **AWC:** Auto white balance control
- ▶ **3200:** Fixed white balance (for indoors)
- ▶ **5600:** Fixed white balance (for outdoors)
- ▶ **FLUORESCENT:** Selects the Fixed white balance mode (for fluorescent lighting).
- ▶ **MWB:** Manual white balance



The configured settings will be applied to “CAM1” or “CAM2”, whichever you selected under [VIEW].

Configuring the Auto Trace White Balance Mode (ATW)

Auto trace white balance (ATW) automatically adjusts the white balance to provide optimal colors, even if the light source for the target object is changed.

Enable the smart ATW function here because ATW may not produce desirable results if a single solid color occupies a large part of the subject.

SETTING ITEMS	SET VALUE
WHITE BALANCE	ATW
MASKING	OFF
SMART ATW	OFF

Buttons: SET, CANCEL, DEFAULT

1 In [WHITE BALANCE], select “ATW”.

2 In [SMART ATW], select “ON” and click **SET**.

The camera now adjusts the white balance automatically based on the color information on the subject.



Do not use the smart ATW function in environments where the color temperature fluctuates. In an outdoor environment for example, smart ATW may not produce desirable results because the color temperature fluctuates depending on the time of the day (at sunrise, daytime, and sunset), weather (sunny or cloudy), and other conditions.

If Subject Includes an Extremely Bright Light Source

1 In [MASKING], select “ON” and click **SET**.

SETTING ITEMS	SET VALUE
WHITE BALANCE	ATW
MASKING	ON
SMART ATW	OFF

Buttons: SET, CANCEL, DEFAULT

The ATW masking screen appears.

Mask the light source by the following procedure.

2 Drag the mouse over the live video image to select the area you want to mask.

The masked area is indicated by blue-bordered grid cells each containing the letter “M”.

You can mask more than one portion of the live image.

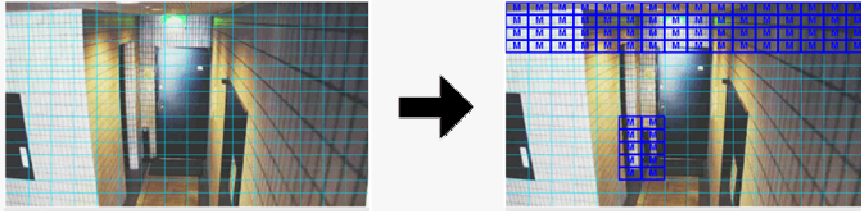

You can click one grid cell after another to set or cancel the masked area cell by cell.
To deselect a block of grid cells in the masked area, right-click one of grid cell and drag the mouse.

3 Click **SET** and then **BACK** .

The settings are saved and you return to the sub menu.

Configuring Auto White Balance Control Mode (AWC)

Use AWC if auto trace white balance (ATW) does not reproduce a natural white balance.

AWC allows you to automatically adjust the white balance by simply clicking **SET** with the camera lens directed toward a white wall, white paper and the like.

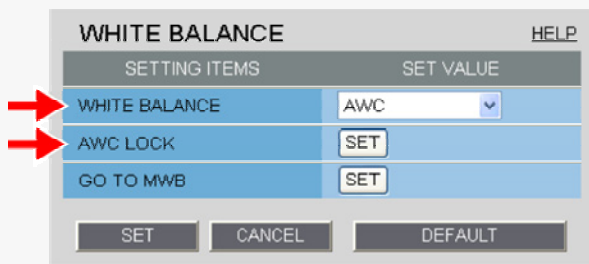

1 In [WHITE BALANCE], select “AWC”.

2 Direct the camera lens toward a white wall, white paper and the like and, in [AWC LOCK], click **SET** .

If the white balance adjustment does not reproduce desirable results, click **SET** again.

You need to follow the above steps also to re-adjust the white balance when the lighting conditions have been changed.



To fine-tune the white balance after this adjustment, in [GO TO MWB], click **SET** .

Configuring Fixed White Balance Mode (3200/5600/FLUORESCENT)

You can set the color temperature to a fixed value.

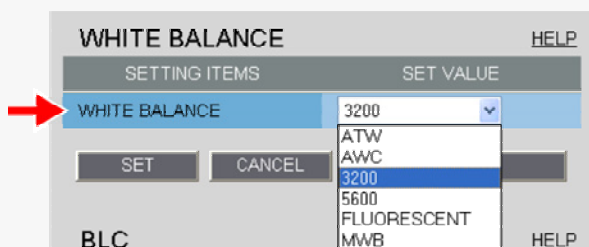

In [WHITE BALANCE], select the desired fixed white balance mode and click **SET**.

- ▶ **3200:** For indoors (Fixes the color temperature to 3200K.)
- ▶ **5600:** For outdoors (Fixes the color temperature to 5600K.)
- ▶ **FLUORESCENT:** For fluorescent lighting (Fixes the color temperature to 4200K.)

Configuring the Manual White Balance Mode (MWB)

Use the following procedure to manually adjust the gain values for the red and blue signals.

WHITE BALANCE		HELP
SETTING ITEMS	SET VALUE	
WHITE BALANCE	MWB	
0-255	RED	64
	BLUE	64

SET CANCEL DEFAULT

1 In [WHITE BALANCE], select “MWB”.

2 In [RED] and [BLUE], specify the gain values for the red and blue signals, respectively, and click **SET**.

- ▶ **RED:** 0 (light) to 255 (dark)
- ▶ **BLUE:** 0 (light) to 255 (dark)

BLC

You can use the backlight compensation (BLC) function to make the subject easily visible under strong backlight conditions.

- ▶ **OFF:** Disables the backlight compensation function.
- ▶ **MULTI:** Selects the multi-spot evaluative metering mode.
- ▶ **CENTER:** Selects the center-weighted evaluative metering mode.
- ▶ **MASKING:** Selects the light source masking mode.
- ▶ **FACE:** Selects the face detection backlight compensation mode.



The configured settings will be applied to “CAM1” or “CAM2”, whichever you selected under [VIEW].

Configuring Multi-Spot Evaluative Metering Mode (MULTI)

Multi-spot evaluative metering compensates for the backlighting problem by evaluating the photometry of the entire screen.

BLC		HELP
SETTING ITEMS	SET VALUE	
BLC	MULTI	
BLC WEIGHT	7	
BRIGHT	7	

SET CANCEL DEFAULT

- 1 In [BLC], select “MULTI”.
- 2 In [BLC WEIGHT], select the backlight sensitivity.
 - ▶ 0 (low sensitivity) to 15 (high sensitivity)
- 3 In [BRIGHT], select the compensation level for the brightness of the backlighting and click **SET**.
 - ▶ 0 (low brightness compensation) to 15 (high brightness compensation)

Configuring Center-Weighted Average Metering Mode (CENTER)

Center-weighted average metering compensates for the backlighting problem by measuring the photometry of the specified area intensively.

Configure the position and size of the center metering area.

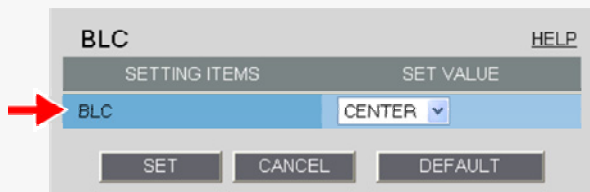

- 1 In [BLC], select “CENTER” and click **SET**.

The BLC center/window weighting setting screen appears, showing a rectangle representing the center metering area in the center of the screen.

- 2 Drag the rectangle to set the center metering area in position.

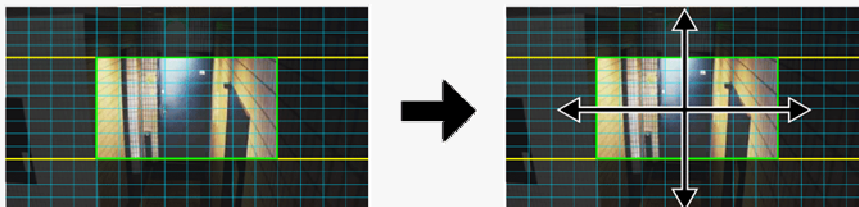

Center-weighted average metering may not be set depending on the position of the center metering area.

- 3 Resize the center metering area.

To resize the center metering area, place the mouse pointer over the border of the area and then drag it.

- 4 Configure the metering weight values for the four surrounding metering areas (TOP, BOTTOM, LEFT, and RIGHT).

Select a weight value for each of these metering areas depending on the installation environment.



SETTING ITEMS	
TOP	0
BOTTOM	0
LEFT	0
RIGHT	0
CENTER	7



SETTING ITEMS	
TOP	3
BOTTOM	5
LEFT	5
RIGHT	3
CENTER	7

▶ 0 (minimum) to 7 (maximum)



The weight value for the center metering area ([CENTER]) is fixed to “7”. You cannot change this value.

The brightness value represents the weight for each area and therefore does not affect the actual live video image from the camera.

5 Click **SET** and then **BACK**.

The settings are saved and you return to the sub menu.

Configuring Light Source Masking Mode (MASKING)

You can use light source masking to compensate for backlighting problems with human or other objects in the subject, by masking the light source in a bright background.

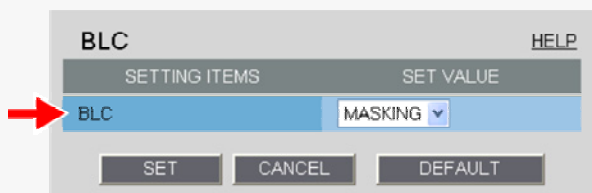

1 In [BLC], select “MASKING” and click **SET**.

The BLC masking screen appears.

2 Drag the mouse over the live video image to select the area you want to mask.

The masked area is indicated by blue-bordered grid cells each containing the letter “M”.

You can mask more than one portion of the live image.

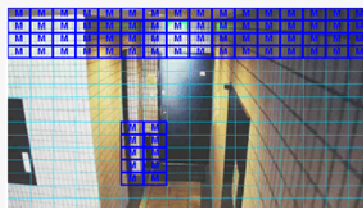
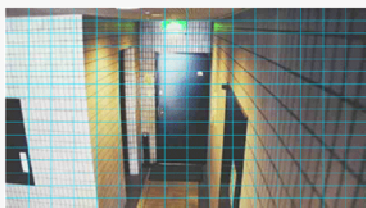

You can click one grid cell after another to set or cancel the masked area cell by cell.

To deselect a block of grid cells in the masked area, right-click one of grid cell and drag the mouse.

3 Click **SET** and then **BACK** .

The settings are saved and you return to the sub menu.

Configuring Face Detection Backlight Compensation Mode (FACE)

Follow the step below to perform backlight compensation when a human face is detected.

A human face may not be detected if obscured by a hat, sunglasses, or mask, or if the monitoring angle is not appropriate.

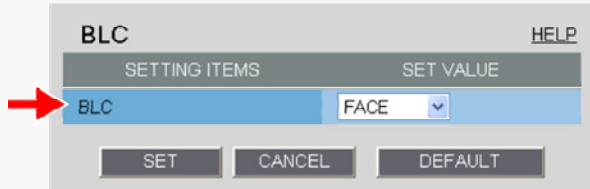

In [BLC], select “FACE” and click **SET** .



With either of the following settings, backlight compensation will not work even if any human face is detected.

- [AGC] is set to “OFF”.
- [SHUTTER] is set to “SHORT” or “LONG”.
- [IRIS] is set to “MANUAL”.

SHUTTER

Configure the electronic shutter according to the movement and luminance level of the target object.

- OFF:** Disables the electronic shutter.
- SHORT:** Enables the fast shutter mode.
- LONG:** Enables the long exposure shutter mode.



The configured settings will be applied to “CAM1” or “CAM2”, whichever you selected under [VIEW].

Configuring Fast Shutter Mode (SHORT)

The fast shutter mode has a shorter exposure time than the field storage time.

Configuring the fast shutter mode enables you to capture quick motion in the subject.



You cannot select “SHORT” to configure the fast shutter mode if the electronic sensitivity boosting ([SENSE UP] in [IRIS]) is enabled.

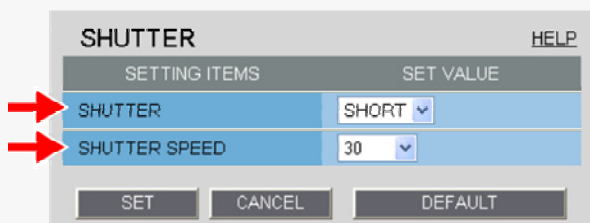

1 In [SHUTTER], select “SHORT”.

2 In [SHUTTER SPEED], select the desired shutter speed and click **SET**.

▶ VCC-HD4600P: 25, 50, 120, 250, 500, 1000, 2000, 4000, 10000

▶ VCC-HD4600: 30, 60, 100, 250, 500, 1000, 2000, 4000, 10000



Each of the above shutter speed values represents the denominator “n” of the fraction 1/n. For example, selecting “500” means to set a shutter speed of 1/500 second.

Configuring Long Exposure Shutter Mode (LONG)

The long exposure shutter mode has a longer exposure time than the field storage time.

The long exposure shutter mode increases the sensitivity of the camera to make the subject brighter.



You cannot select “LONG” to configure the long exposure shutter mode if the electronic sensitivity boosting ([SENSE UP] in [IRIS]) is enabled.

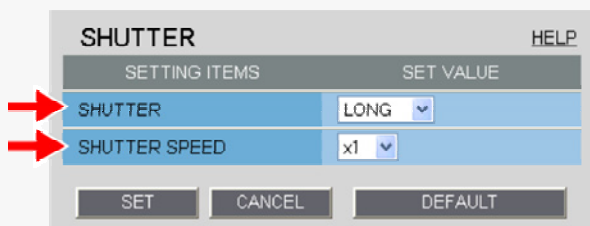

1 In [SHUTTER], select “LONG”.

2 In [SHUTTER SPEED], select the desired shutter speed and click **SET**.

▶ x1, x2, x4, x8, x16, x32



Each of the above shutter speed values represents a multiple of the field storage time. The higher the value, the longer the exposure time.



Setting an excessively long exposure time may result in ghosts, blurs and white spots if the subject includes any moving object.

AGC

Configure the video signal gain value automatically or manually.

Automatically configuring gain value using AGC

Manually configuring gain value



Auto Gain Control (AGC) is a function that automatically adjusts the gain value of the camera's video signal amplifying circuit according to the brightness of the subject to maintain a constant signal output.

The configured settings will be applied to “CAM1” or “CAM2”, whichever you selected under [VIEW].

Automatically configuring gain value using AGC

SETTING ITEMS	SET VALUE
AGC	ON
MAX GAIN	NORMAL

SET CANCEL DEFAULT

1 In [AGC], select “ON”.

2 In [MAX GAIN], select the maximum gain level for AGC and click **SET**.

Selecting a higher gain level will improve the camera sensitivity in a dark condition, but increase the noise as well.

- ▶ **NORMAL:** For normal subject
- ▶ **MIDDLE:** For slightly dark subject
- ▶ **HIGH:** For dark subject



The maximum gain value varies depending on the Day/Night mode.

Manually configuring gain value

SETTING ITEMS	SET VALUE
AGC	OFF
GAIN SETTING	0dB

SET CANCEL DEFAULT



If you set [AGC] to “OFF”, you cannot enable the electronic sensitivity boosting function (in [SENSE UP] in [IRIS]).

You cannot select “OFF” in [AGC] if the Day/Night function ([DAY/NIGHT]) is set to “AUTO” or the electronic sensitivity boosting ([SENSE UP] in [IRIS]) is enabled.

1 In [AGC], select “OFF”.

2 In [GAIN SETTING], select the gain value of AGC and click **SET**.

- ▶ 0dB, 3dB, 6dB, 9dB, 12dB, 15dB, 18dB, 21dB, 24dB, 27dB, 30dB, 33dB, 36dB, 39dB, 42dB

DAY/NIGHT

The Day/Night function improves the camera's sensitivity by automatically switching the camera to the color mode in bright conditions and to the black-and-white mode in dark situations.

Using this function enables 24-hour surveillance with clear video images even during nighttime or in dark locations. You may also fix the camera to the color or black-and-white video mode without using the Day/Night function.

Automatically switching camera between color and black-and-white video modes using Day/Night function

Switching camera between color and black-and-white video modes when an external control signal is received

Fixing camera to color or black-and-white video mode



The configured settings will be applied to “CAM1” or “CAM2”, whichever you selected under [VIEW]. In AUTO mode, turning off the camera in the black-and-white mode and then turning it back on again switches it to the color mode.

The focused position may differ between the color and black-and-white modes.

When using infrared lighting in the black-and-white mode, the camera may switch to the color mode due to strong reflection from objects in the subject. In this case, adjust the infrared lighting to prevent the switching of video to the color mode.

Automatically Switching Camera between Color and Black-and-White Video Modes

SETTING ITEMS	SET VALUE
DAY/NIGHT	AUTO
LEVEL	MIDDLE
INFRARED COMPENSATION	INFRARED

1 In [DAY/NIGHT], select “AUTO”.



If you select “AUTO”, you cannot set [AGC] to “OFF”.

2 In [LEVEL], select the luminance level at which the video mode is switched and click **SET**.

- HIGH:** Sets a high luminance level (to increase the time during which the camera operates in the black-and-white mode).
- MIDDLE:** Sets the luminance level to halfway between “LOW” and “HIGH”.
- LOW:** Sets a low luminance level (to increase the time during which the camera operates in the color mode).
- ADJ:** Enables the manual adjustment of the luminance level.

Manually Configuring Mode-Switching Luminance Level (ADJ)

You can select a luminance level between 1 and 7 for both the color to black-and-white switching and black-and-white to color switching. Switching occurs in darker conditions as the luminance level increases.

SETTING ITEMS	SET VALUE
DAY/NIGHT	AUTO
LEVEL	ADJ
COLOR→B/W	4
B/W→COLOR	4
INFRARED COMPENSATION	INFRARED

COLOR→B/W

Select the luminance level at which switching occurs from the color mode to the black-and-white mode.

B/W→COLOR

Select the luminance level at which switching occurs from the black-and-white mode to the color mode.



Changing one of these settings also changes the other setting based on the difference.

To prevent hunting in infrared (IR) lighting, set these luminance levels to widely different values.

3 In [INFRARED COMPENSATION], select the focus compensation mode.

Normally, select “VISIBLE”. However, if the target gets out of focus, select “INFRARED”.

- ▶ **VISIBLE:** For natural sunlight or normal lighting
- ▶ **INFRARED:** For near-infrared lighting

Switching camera between color and black-and-white video modes when an external control signal is received

Using one of these alarm input terminals as the Day/Night switching terminal, however, enables the camera to be switched between the color and black-and-white video modes when an external control signal is received.

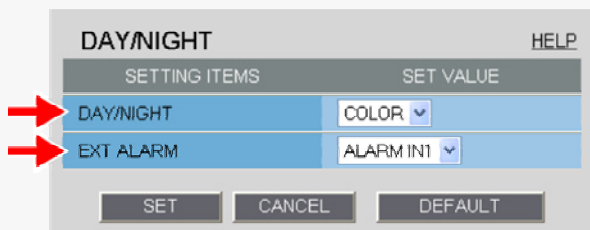

1 In [DAY/NIGHT], select “COLOR”.

2 In [EXT ALARM], select the desired alarm input terminal and click **SET**.

- ▶ **ALARM IN1:** Sets the ALARM IN1 terminal as the Day/Night switching terminal.
- ▶ **ALARM IN2:** Sets the ALARM IN2 terminal as the Day/Night switching terminal.
- ▶ **OFF:** Fixing Camera to Color Video Mode



You need to enable the ALARM IN1/2 terminal and configure the signal polarity in [POLARITY] on the ALARM SETTINGS screen.

Depending on the [POLARITY] setting, the camera will be switched between the color and black-and-white video modes as follows (commonly applied to CAM1 and CAM2):

- If [POLARITY] is set to “NO”: Color mode when open; Black-and-white mode when closed
- If [POLARITY] is set to “NC”: Color mode when closed; Black-and-white mode when open

Fixing camera to color or black-and-white video mode

Fixing Camera to Color Video Mode

In [DAY/NIGHT] and [EXT ALARM], select “COLOR” and “OFF”, respectively, and click **SET**.

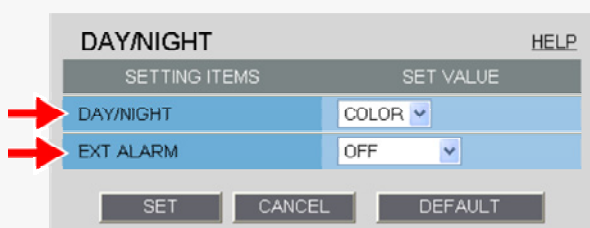

Fixing Camera to Black-and-White Video Mode

1 In [DAY/NIGHT], select “B/W”.

2 In [INFRARED COMPENSATION], select the focus compensation mode.

Normally, select “INFRARED”. However, if the target gets out of focus, select “VISIBLE”.

- ▶ **VISIBLE:** For natural sunlight or normal lighting
- ▶ **INFRARED:** For near-infrared lighting

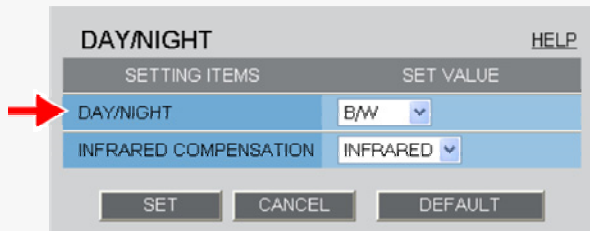

APERTURE

You can use the contour compensation function to make the whole video image clearer.

Select “ON” in [APERTURE] and an appropriate correction level in [LEVEL] and click **SET**.

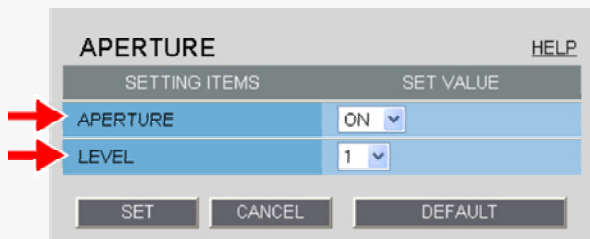

The higher the correction level, the greater the correction effect.

- ▶ 1 to 15



The configured settings will be applied to “CAM1” or “CAM2”, whichever you selected under [VIEW].

VIVID COLOR EFFECT

Use the color saturation compensation function to improve the vividness of the color.

In [VIVID COLOR EFFECT], select “ON” and click **SET**.

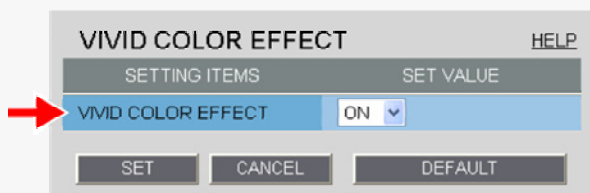

The configured settings will be applied to “CAM1” or “CAM2”, whichever you selected under [VIEW].

GAMMA

Set the gamma correction level to adjust the contrast or brightness level.

In [GAMMA], select the gamma correction level and click **SET**.

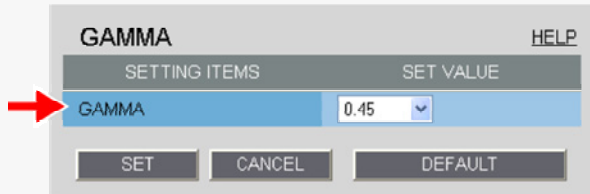

- ▶ **0.45:** Gamma correction level = 0.45
- ▶ **1:** Gamma correction level = 1
- ▶ **MODE1:** Increases the contrast of the whole subject.
- ▶ **MODE2:** Increases the contrast in dark areas further.



The configured settings will be applied to “CAM1” or “CAM2”, whichever you selected under [VIEW].
Selecting “MODE1” or “MODE2” may result in excessively bright images depending on the target object.

FOCUS

Configure the auto or manual focusing mode.

- ▶ **AUTO:** Selects the auto focus mode.
- ▶ **MANUAL:** Selects the manual focus mode (Sets the focusing distance and speed appropriate for the target object).



The configured settings will be applied commonly to “CAM1” and “CAM2” selected under [VIEW].

Configuring the Auto Focus Mode (AUTO)

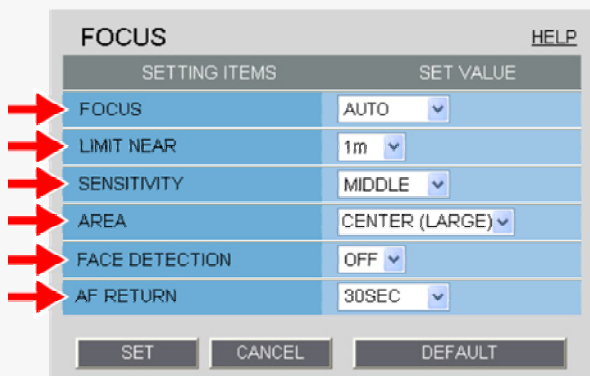

1 In [FOCUS], select “AUTO”.

2 In [LIMIT NEAR], select the nearest focusing distance to the object.

- ▶ 10cm, 30cm, 50cm, 1m, 3m, 5m



When the distance to the object is less than or equal to 1m, focusing may become difficult.

3 In [SENSITIVITY], select the focusing sensitivity.

- ▶ HIGH: Selects the high sensitivity mode.
- ▶ MIDDLE: Selects the standard settings.
- ▶ LOW: Selects the low sensitivity mode.



Selecting “HIGH” may cause the camera to react to movements of the target too sensitively. If so, select to “LOW”.

4 In [AREA], select the auto focusing area.

- ▶ FULL: Full screen
- ▶ CENTER(LARGE): Selects the center of screen (larger area)
- ▶ CENTER(SMALL): Select the center of the screen (Small area).

5 In [FACE DETECTION], enable or disable auto focusing in face detection.

Use this setting to specify whether or not to use the auto focus function when a human face is detected in the focusing area you selected in [AREA].

- ▶ OFF: Disables auto focusing in face detection.
- ▶ ON: Enables auto focusing in face detection.



A human face may not be detected if obscured by a hat, sunglasses, or mask, or if the monitoring angle is not appropriate.

6 In [AF RETURN], configure the function to automatically return to the auto focus mode, and then click **SET**.

Using this function, you can return to the auto focus mode automatically after focusing the target manually.

- ▶ 20SEC, 30SEC, 40SEC, 50SEC, 1MIN, 2MIN, 3MIN, 4MIN, 5MIN
Returns the focus mode automatically to the auto focus after the specified time (any of above values) has passed.
- ▶ AUTO:
Returns the camera to the auto focus mode when the zoom operation is performed after manual focusing.

Configuring the Manual Focus Mode (MANUAL)

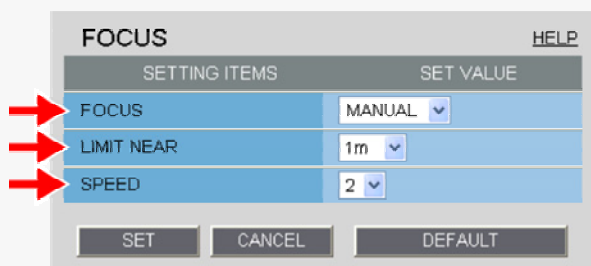

1 In [FOCUS], select “MANUAL”.

2 In [LIMIT NEAR], select the nearest focusing distance to the object.

- ▶ 10cm, 30cm, 50cm, 1m, 3m, 5m



When the distance to the object is less than or equal to 1m, focusing may become difficult.

3 In [SPEED], specify the speed at which the focus is set, and then click **SET** .

▶ Available settings: 1, 2, 3, and 4 (fastest)

ZOOM

Configure the optical zoom speed, electronic zoom magnification, and other zoom settings.



The configured settings will be applied commonly to “CAM1” and “CAM2” selected under [VIEW].

SETTING ITEMS	SET VALUE
SPEED	3
EL.ZOOM	OFF
V-RESO.UP	OFF

1 In [SPEED], select the optical zoom speed.

▶ Available settings: 1, 2, 3, and 4 (fastest)

2 In [EL ZOOM], select the electronic zoom magnification power.

The optical zoom provides a maximum magnification power of $\times 10$.

If you need a zoom magnification of more than $\times 10$, use the electronic zoom.

▶ OFF: Disables the electronic zoom (use optical zoom only).

▶ 2x (approx. 20 times), 4x (approx. 40 times), 8x (approx. 80 times), 16x (approx. 160 times)



The electronic zoom, if activated, will degrade the quality of image slightly.

3 In [V-RESO.UP], configure the vertical resolution boost function, and then click **SET** .

▶ ON: Enables the vertical resolution increase function of the electronic zoom.

▶ OFF: Does not increase vertical resolution while using the electronic zoom.

DNR

Configure the DNR (Digital Noise Reduction) function to reduce noise at low conditions.

In [DNR], select “ON” and click **SET** .

SETTING ITEMS	SET VALUE
DNR	ON



The configured settings will be applied to “CAM1” or “CAM2”, whichever you selected under [VIEW].
Enabling the DNR function may cause ghosts and blurs if the subject includes any moving object, which results in low resolution.

MIRROR

Use the mirror function to electronically flip the displayed subject.

If you installed the camera upside down or intend to monitor the subject in the mirror, configure the following settings according to the installation environment of the camera.

In [MIRROR], select the desired mirror mode and click **SET**.

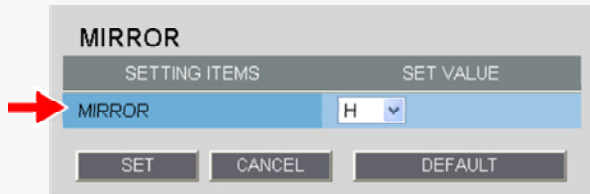

- ▶ **OFF:** Disables the mirror mode (normal video).
- ▶ **H:** Flips the video horizontally.
- ▶ **V:** Flips the video vertically.
- ▶ **HV:** Flips the video vertically and horizontally.



The configured settings will be applied commonly to “CAM1” and “CAM2” selected under [VIEW].

PRIVACY MASK

You can configure the privacy mask settings to hide specific portions of surveillance video for privacy protection. When a privacy mask is set, the resolution, frame rate, and image quality of the live video image may be limited.



The configured settings will be applied commonly to “CAM1” and “CAM2” selected under [VIEW].

1 Click [PRIVACY MASK] in the sub menu.

The PRIVACY MASK SETTINGS screen appears.



The mask setting screen shows the video at the angle of view that you see on the live screen. On the mask setting screen, you can perform digital zooming. For details, refer to the “Using Digital PTZ Function” section.

2 Drag the mouse over the live video image to select the area you want to mask.

A mask pattern appears over the selected area.

You can set up to eight mask patterns on the screen.

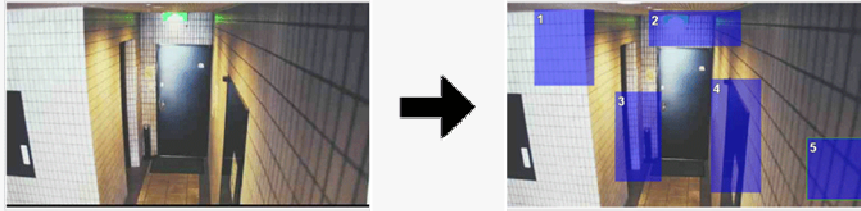

To select a mask pattern, just click on it. The selected mask pattern is shown with a yellow green border.

To move a mask pattern, select it and then drag the mouse. To resize a mask pattern, place the mouse pointer over its border and then drag the mouse.

To delete a set mask pattern, click the **DELETE** button corresponding to the pattern number or drag it out of the screen.

3 Select the [SETTING ITEMS] check box.

Each mask pattern for which you selected the check box appears on the live screen. You may select two or more check boxes.

SETTING ITEMS	SET VALUE
<input checked="" type="checkbox"/> MASK 1	DELETE
<input type="checkbox"/> MASK 2	DELETE
<input checked="" type="checkbox"/> MASK 3	DELETE
<input type="checkbox"/> MASK 4	DELETE
<input checked="" type="checkbox"/> MASK 5	DELETE
<input type="checkbox"/> MASK 6	DELETE
<input type="checkbox"/> MASK 7	DELETE
<input type="checkbox"/> MASK 8	DELETE
COLOR	BLACK
SEMI TRANSPARENT	OFF
<input type="button" value="SET"/> <input type="button" value="CANCEL"/> <input type="button" value="DEFAULT"/> <input type="button" value="BACK"/>	

4 In [COLOR], select the color of the mask pattern(s).

► BLACK, GREY, WHITE, RED, BLUE

5 In [SEMI TRANSPARENT], select whether to enable or disable the transparency of the mask pattern(s).

► OFF (Disables transparency), ON (Enables transparency)

6 Click **SET** and then **BACK**.

The settings are saved and you return to the sub menu.

ALARM SETTINGS

Click **ALARM** in the configuration menu to display the ALARM SETTINGS screen.

If you want the camera to record surveillance video or transmit a warning signal by detecting an alarm condition, configure the following settings on this screen.

- A Detecting an alarm condition via alarm input terminal**
- B Detecting an alarm condition via built-in motion sensor**
- C Outputting an alarm signal from alarm output terminal**



Required operation privilege: admin, operator1



To record video by detecting an alarm condition, after completing the configuration on this screen, you must select an alarm event in [ALARM EVENT] on the RECORDING screen.

A Detecting an alarm condition via alarm input terminal

Configure the input conditions of each alarm input terminal provided on the rear face of the camera.

SETTING ITEMS	SET VALUE
ALARM IN1	OFF
POLARITY	NO
ACTION	OFF
DURATION	5SEC



Before you start the following procedure, connect an external alarm device to one of the alarm input terminals ("ALARM IN1" in this example).
For details, refer to the "Alarm Input/Output Terminal Connections" section.

1 In [ALARM IN1], select "ON".

2 In [POLARITY], select the signal polarity of the alarm input terminal.

- ▶ **NO (Normally Open):** The terminal is normally open and closes when an alarm signal is received.
- ▶ **NC (Normally Closed):** The terminal is normally closed and opens when an alarm signal is received.

3 Select how you want the camera to behave upon receiving alarm input (ACTION).

- ▶ **OFF:** Disables the camera action when an alarm signal is input.
- ▶ **ZOOM:** Zooms in or out to the specified zoom magnification when an alarm signal is input.
→ When you select [ZOOM], configure [RATIO] and [ZOOM TIME].
- ▶ **CAM1/CAM2:** Switches to the monitoring condition configured under [VIEW] (CAM1 or CAM2) when an alarm signal is input.
→ When you select [CAM1] or [CAM2], configure [RETURN].

The settings required when "ZOOM" is selected

SETTING ITEMS	SET VALUE
ALARM IN1	ON
POLARITY	NO
ACTION	ZOOM
RATIO	x1
ZOOM TIME	5SEC
DURATION	5SEC

1 In [RATIO], select the zoom magnification power.

▶ x1, x1.4, x2, x2.8, x4, x5.6, x8, x10

2 In [ZOOM TIME], select how long you want the target to be zoomed in.

Select the value within the duration configured in [DURATION] (Step **4** below).

▶ 5SEC, 10SEC, 15SEC, 20SEC, 30SEC, 45SEC, 1MIN, 2MIN, 3MIN, 4MIN, 5MIN



The duration configured in [ZOOM TIME] is the period in which zoomed state is retained after the camera has zoomed in or out to the specified magnification.

After the duration set in [ZOOM TIME] has passed, the zoom magnification before the alarm will be restored.

Depending on the value selected in [DURATION], the setting in [ZOOM TIME] may be overridden by the setting in [DURATION].

The settings required when [CAM1] or [CAM2] is selected

SETTING ITEMS	SET VALUE
ALARM IN1	ON
POLARITY	NO
ACTION	VIEW1
RETURN	OFF
DURATION	5SEC

In [RETURN], select whether to retain the monitoring conditions loaded when an alarm signal was input even after the alarm action, or return to the previous monitoring conditions.

▶ **OFF:** Retains the monitoring condition after the alarm.

▶ **ON:** Returns to the monitoring condition before the alarm (auto-recovery function)



If you select "ON" for [RETURN], the system will return to the previous operating conditions before an alarm action took place, when the alarm duration (DURATION) expires.

When you perform zoom or preset position monitoring operations during the alarm condition, the auto-recovery function will be disabled.

4 In [DURATION], select how long you want the alarm state to be retained when the terminal receives an alarm signal and click **SET**.

The terminal will not accept subsequent alarm signals until the set duration expires.

▶ 5SEC, 10SEC, 15SEC, 20SEC, 30SEC, 45SEC, 1MIN, 2MIN, 3MIN, 4MIN, 5MIN

▶ CC (Retains the alarm state as long as the alarm signal persists.)



If an alarm condition is detected, alarm recording will last until the time specified in [DURATION] expires.

The alarm state will be retained for at least 5 seconds even if the alarm signal is instantaneous.

The configured duration value will be reset to the factory default value if you change any setting on the ALARM SETTINGS screen while an alarm state is retained.

To configure the ALARM IN2 terminal to detect an alarm condition, select “ON” in [ALARM IN2] and specify the input conditions for it in the same way as for the ALARM IN1 terminal.

B Detecting an alarm condition via built-in motion sensor

This camera offers the built-in motion sensor function that automatically detects motion in the subject. The motion sensor detects an alarm condition in three ways as follows.

- A Disabling motion detection in masked areas
- B Detecting motion in specific areas
- C Detecting motion with lines and areas drawn on the screen

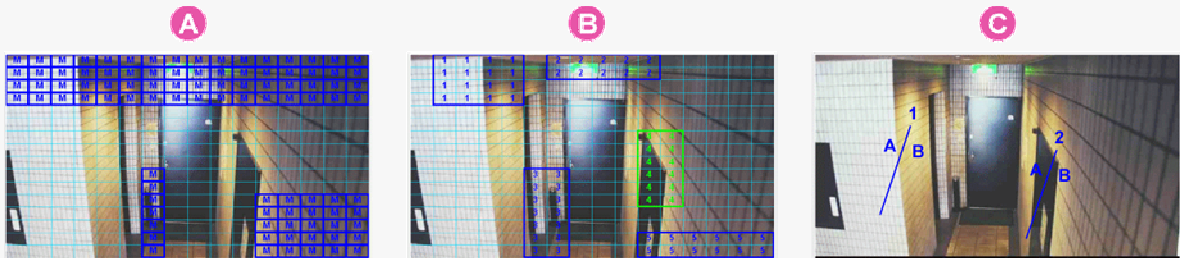

You cannot configure the motion sensor function if the electronic sensitivity boosting (SENSE UP) or the long exposure shutter mode (LONG) is enabled.

A Disabling motion detection in masked areas

Use the motion masking function to detect motion in the whole screen area, except for masked areas. Set a mask over any swaying tree, flickering light source, or other object to prevent unwanted detection.

- 1 On the ALARM SETTINGS screen, in [MOTION], select “MASKING”.
- 2 In [DURATION], select how long you want the alarm state to be retained when the motion sensor detects motion and click **DETAIL**.

The motion mask configuration screen appears.

- ▶ 5SEC, 10SEC, 15SEC, 20SEC, 30SEC, 45SEC, 1MIN, 2MIN, 3MIN, 4MIN, 5MIN
- ▶ CC (Retains the alarm state as long as the motion alarm persists.)



The terminal will not accept subsequent alarm signals until the set duration expires.

The alarm state will be retained for at least 5 seconds even if the motion is instantaneous.

The configured duration value will be reset to the factory default value if you change any setting on the ALARM SETTINGS screen while an alarm state is retained.



To switch the alarm detection method, in [MOTION ALARM], click the desired radio button.

3 Drag the mouse over live video/image to select the area you want to mask.

The masked area is indicated by blue-bordered grid cells each containing the letter “M”. You can mask as many areas as you want without limitation.

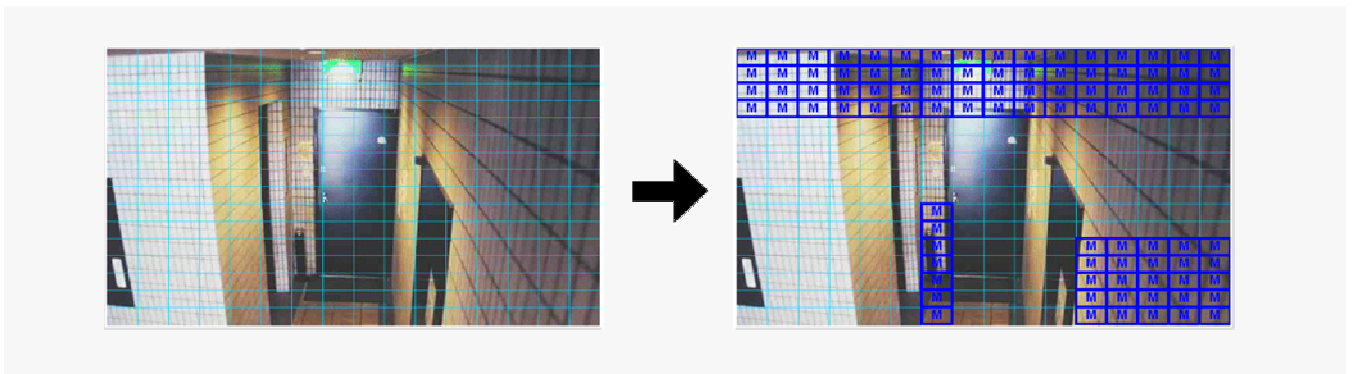

You can unmask one grid cell at a time by clicking each grid cell in a masked area. To deselect a block of grid cells in the masked area, right-click one of grid cell and drag the mouse.

4 In [SENSITIVITY], select the detection sensitivity.

The higher the value, the lower the sensitivity.

▶ 1 to 9



5 In [FACE DETECTION], select “ON” to use the face detection function.

The face detection function judges whether or not the subject includes any intruder by detecting his/her face. If a human face is detected in the detection area when motion is detected, the motion sensor will send a motion alarm.



A human face may not be detected if obscured by a hat, sunglasses, or mask, or if the monitoring angle is not appropriate.

Checking how the motion sensor works

Click **TEST**.

If any motion is detected in a grid cell outside the masked area(s), that grid cell will be shown in red. Correct the detection conditions as required.



While the sensor is working, this button is labeled as **END**. To finish checking the motion sensor, click the button.

6 Click **SET** and then **BACK**.

The settings are saved and you return to the ALARM SETTINGS screen.

B Detecting motion in specific areas

Use the motion detection function to detect motion in specific areas of the subject.

1 On the ALARM SETTINGS screen, in [MOTION], select “DETECT”.

2 In [DURATION], select how long you want the alarm state to be retained when the motion sensor detects motion and click **DETAIL**.

The detection area configuration screen appears.

- ▶ 5SEC, 10SEC, 15SEC, 20SEC, 30SEC, 45SEC, 1MIN, 2MIN, 3MIN, 4MIN, 5MIN
- ▶ CC (Retains the alarm state as long as the motion alarm persists.)



The terminal will not accept subsequent alarm signals until the set duration expires.
The alarm state will be retained for at least 5 seconds even if the motion is instantaneous.
The configured duration value will be reset to the factory default value if you change any setting on the ALARM SETTINGS screen while an alarm state is retained.

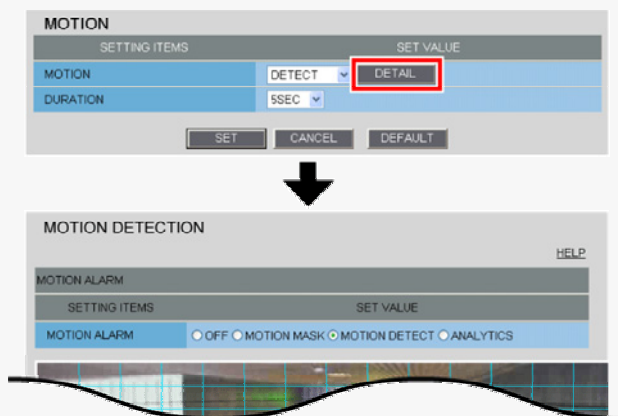

To switch the alarm detection method, in [MOTION ALARM], click the desired radio button.

3 Drag the mouse over live video/image to select the detection area.

You can set up to five detection areas.

Each detection area will be given a number (1 to 5) as you add it. The currently selected area is shown in yellow green.

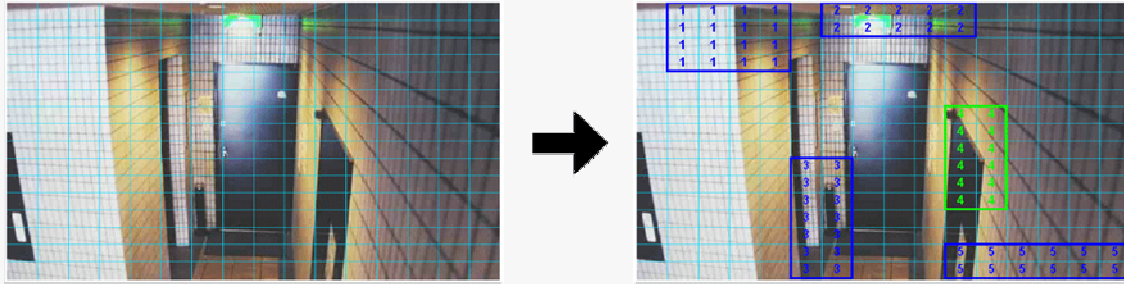

To move a detection area, select it and then drag the mouse.

To resize a detection area, place the mouse pointer over its border and then drag the mouse.

To delete a set detection area, click the **DELETE** button (1) corresponding to the detection area number or drag it out of the screen.

4 In [AREA], select the check box next to the area number of the area you want to enable.

You may select two or more check boxes.

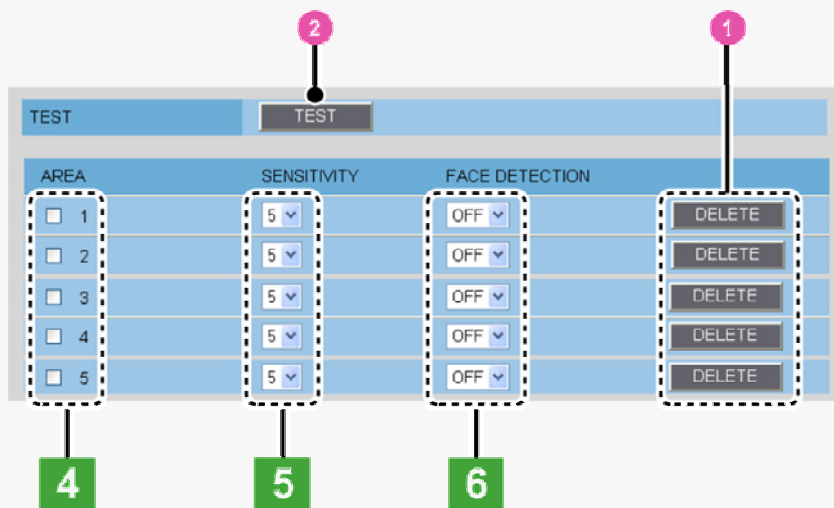

5 In [SENSITIVITY], select the detection sensitivity.

You can adjust the detection sensitivity to prevent unwanted detection.

The higher the value, the lower the sensitivity.

▶ 1 to 9

6 In [FACE DETECTION], select “ON” to use the face detection function.

The face detection function judges whether or not the subject includes any intruder by detecting his/her face.

If a human face is detected in the detection area when motion is detected, the motion sensor will send a motion alarm.



A human face may not be detected if obscured by a hat, sunglasses, or mask, or if the monitoring angle is not appropriate.

Checking how the motion sensor works

Click **TEST** (2).

If any motion is detected in a grid cell in the detection area, that cell will be shown in red.

Correct the detection conditions as required.



While the sensor is working, this button is labeled as **END** . To finish checking the motion sensor, click the button.

7 Click **SET** and then **BACK** .

The settings are saved and you return to the ALARM SETTINGS screen.

C Detecting motion with lines and areas drawn on the screen

You can set lines or areas that represent limit lines or restricted areas on the screen and detect motion that crosses those lines or moves in and out of those areas.



This function is available only for streams for which you set [CODEC] to “H.264” on the VIDEO & AUDIO SETTINGS screen.

1 On the ALARM SETTINGS screen, in [MOTION], select “ANALYTICS”.

2 In [DURATION], select how long you want the alarm state to be retained when the motion sensor detects motion and click **DETAIL** .

The video analytics configuration screen appears.

- ▶ 5SEC, 10SEC, 15SEC, 20SEC, 30SEC, 45SEC, 1MIN, 2MIN, 3MIN, 4MIN, 5MIN
- ▶ CC (Retains the alarm state as long as the motion alarm persists.)



The terminal will not accept subsequent alarm signals until the set duration expires.
 The alarm state will be retained for at least 5 seconds even if the motion is instantaneous.
 The configured duration value will be reset to the factory default value if you change any setting on the ALARM SETTINGS screen while an alarm state is retained.

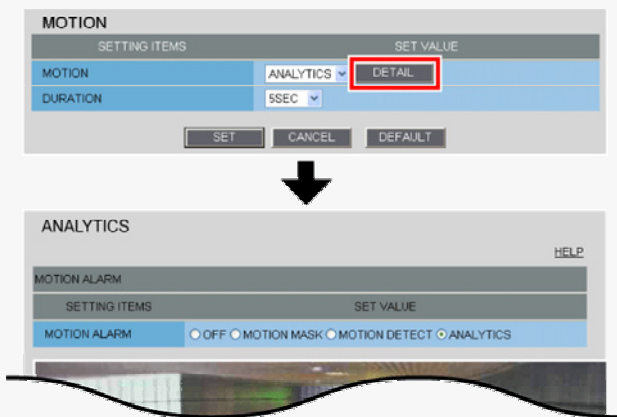

To switch the alarm detection method, in [MOTION ALARM], click the desired radio button.

3 Select the video stream.



The pull-down menu shows a list of streams for which you selected “H.264” in [CODEC] on the VIDEO & AUDIO SETTINGS screen. A warning message will appear if there is no H.264 stream available.

4 Select the radio button to specify whether to set detection lines or areas and configure the detection conditions. When finished, click **SET** and then **BACK** .

You need to use the radio buttons for configuration; however, you can view the set detection lines and areas altogether.

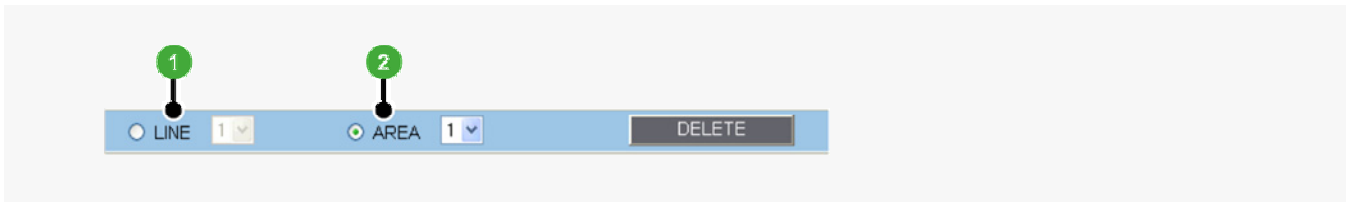

1 Setting detection lines

Select the radio button next to [LINE] and drag the mouse to draw detection lines.

You can draw up to eight detection lines.

Each detection line has a serial number (1 to 8) and area designations (A and B).

2 Setting detection areas

Select the radio button next to [AREA] and drag the mouse to draw detection areas.

You can draw up to four detection areas.

Each detection area has a serial number (1 to 4) and area designations (A and B).

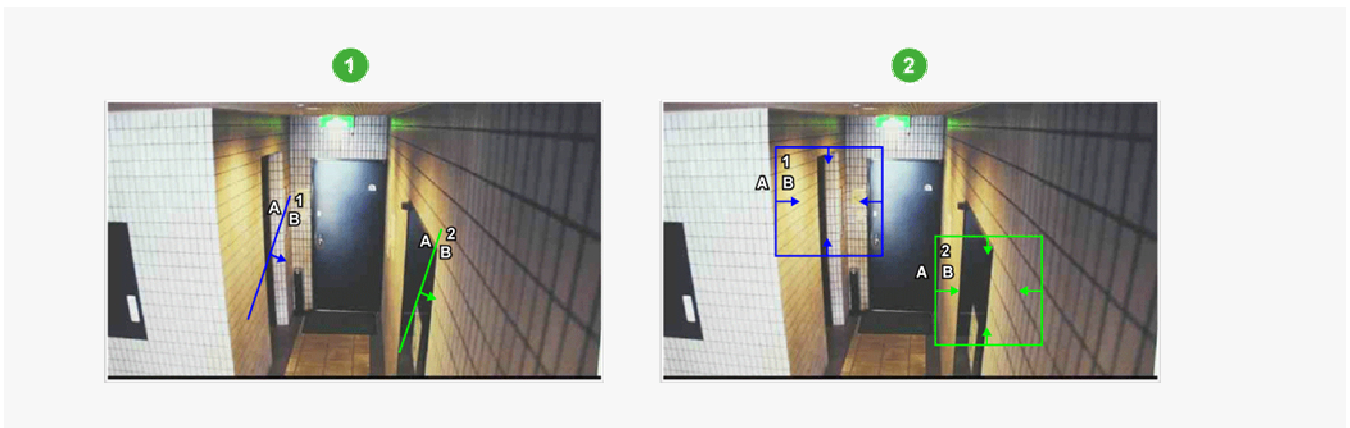

3 Configuring detection conditions

Select the [LINE] or [AREA] radio button to select a line or area number, and specify detection conditions.



To delete a detection line or area, click the [LINE] or [AREA] radio button to select a line or area number, and click **DELETE** .

<Example: Configuring detection conditions for LINE 1>

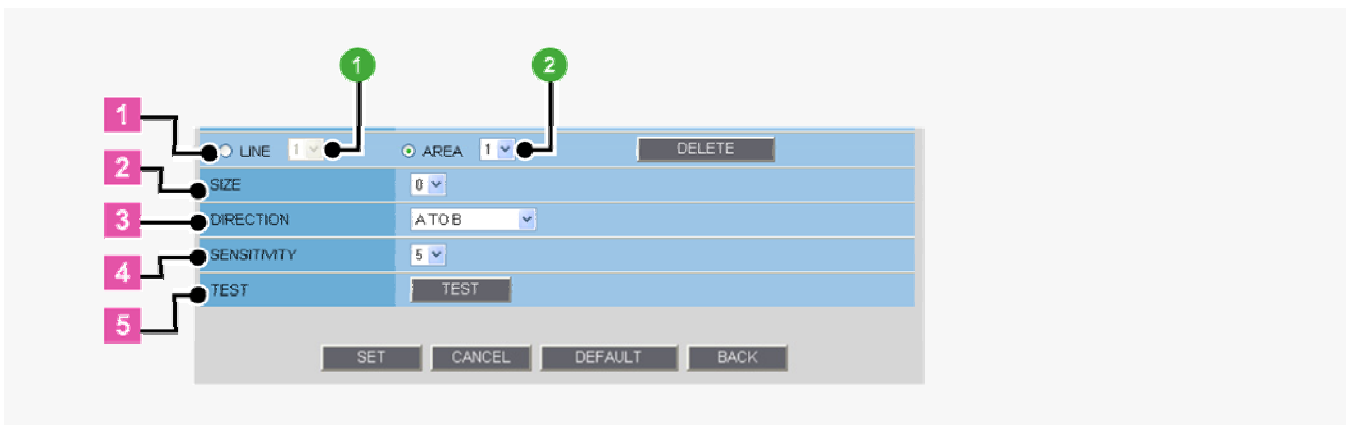

1 Select the [LINE] radio button and, in the pull-down menu, select the line number “1”.

2 In [SIZE], select the size of the object you want to detect.

Specify the size of the object you want to detect.

The higher the value, the larger the detectable object size.

The detection line (or detection area) is now shown with an image that represents the detection size. Any object larger than this image will be detected.

▶ 0 to 5



Selecting “0” means that objects will be detected regardless of their size. In this case, the detection size image is not shown.

3 In [DIRECTION], specify the direction of the object movement you want to detect.

The detection line (or detection area) is now shown with an arrow that represents the direction of the object movement to be detected.

- ▶ **A TO B:** Detects object movement from A to B.
- ▶ **B TO A:** Detects object movement from B to A.
- ▶ **A TO B, B TO A:** Detects object movement between A and B, in both directions.

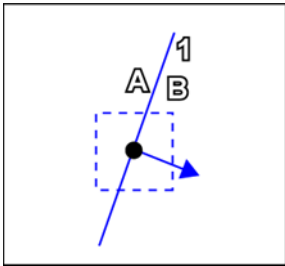

(Ex. Appearance of detection line)

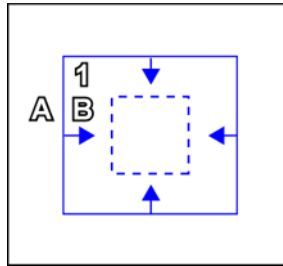

(Ex. Appearance of detection area)

* For the size and direction of the object to be detected when you selected [AREA], refer to the above figure on the right.

4 In [SENSITIVITY], select the detection sensitivity.

You can adjust the detection sensitivity to prevent unwanted detection.

The higher the value, the lower the sensitivity.

▶ 1 to 9

5 Click **TEST** to check how the motion sensor works with the current settings.

If any motion is detected with respect to the detection line (or detection area), that line will be shown in red. Correct the detection conditions as required.



While the sensor is working, this button is labeled as **END**. To finish checking the motion sensor, click the button.

During the test, you cannot change line/area settings.

C Outputting an alarm signal from alarm output terminal

Configure the output conditions for each alarm output terminal.

- ▶ **A Configuring automatic alarm output:** Configure the terminal so that it outputs an alarm signal automatically when an alarm condition is detected.
- ▶ **B Configuring remote alarm output:** Configure the terminal so that it outputs an alarm signal when the corresponding Remote Alarm button is clicked.



Before you start the following procedure, connect an external alarm device to one of the alarm output terminals (“ALARM OUT1” in this example).

For details, refer to the “Alarm Input/Output Terminal Connections” section.

A Configuring Automatic Alarm Output

ALARM OUT	
SETTING ITEMS	SET VALUE
ALARM OUT1	ON
POLARITY	NO
ALARM OUT TIME	5SEC
TRIGGER	
ALARM IN	ALARM IN1
MOTION	OFF

1 In [ALARM OUT1], select “ON”.

2 In [POLARITY], select the signal polarity of the alarm output terminal.

- ▶ **NO (Normally Open):** The terminal is normally open and closes when an alarm signal is output.
- ▶ **NC (Normally Closed):** The terminal is normally closed and opens when an alarm signal is output.

3 In [ALARM OUT TIME], select how long you want the terminal to output an alarm signal.

The terminal will stop outputting the alarm signal when the set alarm output time expires.

- ▶ 2SEC, 5SEC, 10SEC, 15SEC, 30SEC, 45SEC, 1MIN, 2MIN, 3MIN, 4MIN, 5MIN



The alarm output time must be specified within the duration of the alarm input terminal you select under [TRIGGER].

4 Under [TRIGGER], configure the following alarm output conditions and click **SET**.

TRIGGER	
ALARM IN	ALARM IN1
MOTION	OFF

ALARM IN

Specify the alarm input terminal to which the alarm input device is connected. The ALARM OUT 1 terminal outputs an alarm signal when this terminal receives an alarm signal.

- ▶ **ALARM IN1:** The terminal outputs an alarm signal when the ALARM IN1 terminal receives an alarm signal.
- ▶ **ALARM IN2:** The terminal outputs an alarm signal when the ALARM IN2 terminal receives an alarm signal.

MOTION

You can configure the alarm output conditions in conjunction with the motion alarm function.

- ▶ **OFF:** The terminal does not output an alarm signal even when motion is detected in the subject by the motion sensor.
- ▶ **ON:** The terminal outputs an alarm signal when motion is detected in the subject by the motion sensor.

* To configure the ALARM OUT 2 terminal to output an alarm signal, select “ON” in [ALARM OUT2] and specify the output conditions for it in the same way as for the ALARM OUT1 terminal.

B Configuring Remote Alarm Output

ALARM OUT	
SETTING ITEMS	SET VALUE
ALARM OUT1	REMOTE ▾
POLARITY	NO ▾
ALARM OUT TIME	5SEC ▾

1 In [ALARM OUT1], select “REMOTE”.



Selecting “REMOTE” does not cause the terminal to output an alarm signal automatically even if an alarm condition is detected.

2 In [POLARITY], select the signal polarity of the alarm output terminal.

- ▶ **NO (Normally Open):** The terminal is normally open and closes when an alarm signal is output.
- ▶ **NC (Normally Closed):** The terminal is normally closed and opens when an alarm signal is output.

3 In [ALARM OUT TIME], select how long you want the terminal to output the alarm signal and click **SET**.

The terminal will stop outputting the alarm signal when the set alarm output time expires.

- ▶ 2SEC, 5SEC, 10SEC, 15SEC, 30SEC, 45SEC, 1MIN, 2MIN, 3MIN, 4MIN, 5MIN
- ▶ CC (Stops outputting the alarm signal when the corresponding Remote Alarm button is clicked on the live screen.)

To configure the ALARM OUT 2 terminal to output an alarm signal when a Remote Alarm button is clicked, select “REMOTE” in [ALARM OUT2] and specify the output conditions for it in the same way as for the ALARM OUT1 terminal.

RECORDING

Click **RECORDING** button in the configuration menu to display the RECORDING screen.

Configure the recording conditions on this screen if you intend to record video on a SD memory card installed in the camera or an external hard disk drives.



Required operation privilege: admin, operator1

1 In [RECORD STREAM], select the stream you want to record for each recording mode.

Based on the [RECORDING] settings on the VIDEO & AUDIO SETTINGS screen, the selectable stream is displayed for each recording mode.

The pull-down menu displays the image conditions of the selected stream.

- ▶ OFF (no recording), STREAM1, STREAM2, STREAM3, STREAM4

SETTING ITEMS	SET VALUE	
NORMAL	OFF	
RECORD STREAM	ALARM	OFF
RECORD STREAM	NETWORK FAILURE	OFF
NETWORK FAILURE TIME	30SEC	
AUDIO	OFF	
ALTERATION DETECTION	OFF	

NORMAL:

Normal live video is recorded.

- Configure the recording time on the SCHEDULE SETTINGS screen.

ALARM:

Alarm video is recorded.

- Configure the recording conditions in [ALARM EVENT1] to [ALARM EVENT4] (step 4).

NETWORK FAILURE:

If a network failure occurs during network recording, backup recording is performed until the failure is resolved.

- In [NETWORK FAILURE TIME], select the time from the occurrence of a network failure until the camera recognizes it as a recording trigger.

- ▶ 15SEC, 20SEC, 30SEC, 40SEC, 50SEC, 1MIN, 2MIN, 3MIN, 4MIN, 5MIN



The setting values are interlocked among RECORDING, E-MAIL SETTINGS, and FTP SETTINGS screens. (Note that the setting configured most recently will take precedence.)

2 To simultaneously record the video and sound, set [AUDIO] to “ON”.

3 To detect tampered images, set [ALTERATION DETECTION] to “ON”.

4 Configure recording conditions for [ALARM EVENT1].

You can configure four patterns of recording conditions (for ALARM EVENT1 to ALARM EVENT4) and use the optimal pattern depending on the monitoring purpose of the camera.

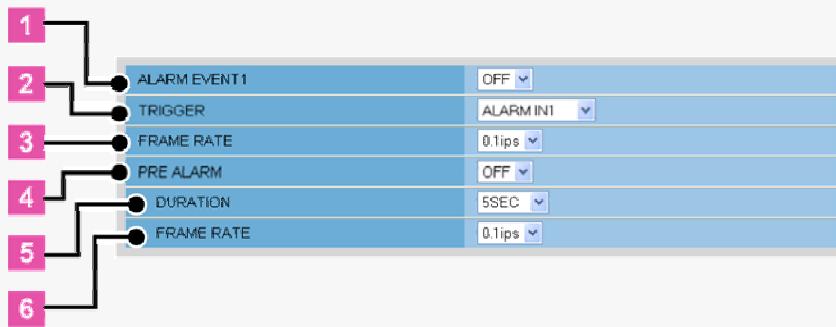

<Example: Configuring recording conditions for ALARM EVENT1>

1 In [ALARM EVENT1], select “ON”.

2 In [TRIGGER], select the recording trigger condition.

- ▶ **ALARM IN1:** Triggers recording when the ALARM IN1 terminal receives an alarm signal.
- ▶ **ALARM IN2:** Triggers recording when the ALARM IN2 terminal receives an alarm signal.
- ▶ **MOTION:** Triggers recording when the motion sensor detects motion in the subject.
- ▶ **ALARM OUT1:** Triggers recording when the ALARM OUT 1 terminal outputs an alarm signal.
- ▶ **ALARM OUT2:** Triggers recording when the ALARM OUT 2 terminal outputs an alarm signal.



If “ALARM IN1” is selected here, no subsequent alarm recording will be triggered while an alarm recording triggered by the ALARM IN1 trigger is in progress, even when the ALARM IN2 terminal receives an alarm signal.

The ALARM IN1 trigger will take precedence if the ALARM IN1 and ALARM IN2 terminals receive an alarm signal simultaneously.



You need to configure the alarm input/output conditions on the ALARM SETTINGS screen.

The duration of recording initiated by each trigger is as follows.

ALARM IN1/ALARM IN2/MOTION: Time selected in [DURATION] under [ALARM IN] on ALARM SETTINGS screen

ALARM OUT1/ ALARM OUT2: Time selected in [ALARM OUT TIME] under [ALARM OUT] on ALARM SETTINGS screen

3 In [FRAME RATE], set the frame rate of the post-alarm video stream.

- ▶ VCC-HD4600: 0.1ips, 0.2ips, 0.5ips, 1ips, 3ips, 5ips, 10ips, 15ips, 30ips
- ▶ VCC-HD4600P: 0.1ips, 0.2ips, 0.5ips, 1ips, 2.5ips, 5ips, 8ips, 12.5ips, 25ips



Here, you can select a frame rate slower than that set for the stream.

If you selected a H.264 stream in [RECORD STREAM], you cannot change the value specified in [FRAME RATE].

The frame rate is limited when [AUDIO], [ALTERATION DETECTION], and [PRE ALARM] are set to “ON”.

The frame rate setting will be applied commonly to the ALARM EVENT1 to ALARM EVENT4 settings.

4 To perform pre-alarm recording, in [PRE ALARM], select “ON”.

You can now record the video for a specific period before and after the occurrence of an alarm.

5 If you selected “ON” in [PRE ALARM]

In [DURATION], select how long you want to perform pre-alarm recording.

- ▶ 5SEC, 10SEC, 15SEC, 20SEC, 30SEC, 45SEC, 1MIN, 2MIN, 3MIN, 4MIN, 5MIN



The pre-alarm recording duration setting applies commonly to the ALARM EVENT1 to ALARM EVENT4 settings.

6 If you selected a JPEG stream in [RECORD STREAM], in [FRAME RATE], select the frame rate of the stream.

In [FRAME RATE], set the frame rate of the pre-alarm video stream.

- ▶ VCC-HD4600: 0.1ips, 0.2ips, 0.5ips, 1ips, 3ips, 5ips, 10ips, 15ips, 30ips
- ▶ VCC-HD4600P: 0.1ips, 0.2ips, 0.5ips, 1ips, 2.5ips, 5ips, 8ips, 12.5ips, 25ips



Here, you can select a frame rate slower than that set for the stream.

If you selected a H.264 stream in [RECORD STREAM], you cannot change the value specified in [FRAME RATE].

The frame rate is limited when [AUDIO], [ALTERATION DETECTION], and [PRE ALARM] are set to “ON”.

The frame rate setting will be applied commonly to the ALARM EVENT1 to ALARM EVENT4 settings.

5 In [REC BUTTON], configure the recording conditions for emergency recording and click **SET.**

You can record suspicious motion in the surveillance video by clicking the emergency recording button () on the live screen.

Here you can set recording duration and frame rate.

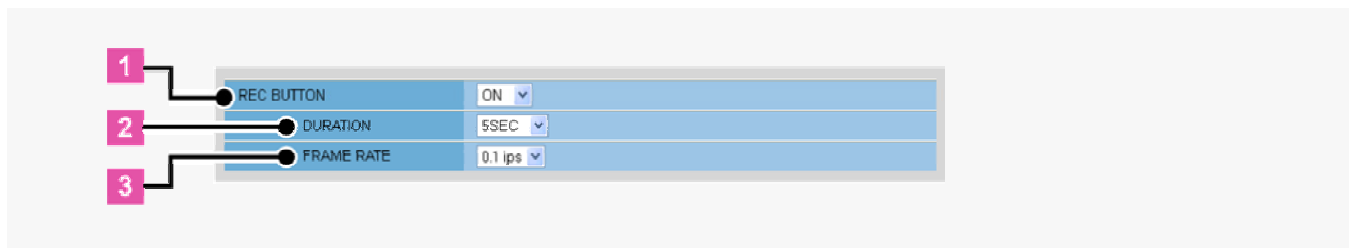

1 Select “ON” for [REC BUTTON].

If you select “OFF”, the emergency recording button is not displayed on the live screen.

2 Specify a recording time (DURATION).

- ▶ MANUAL (Stops recording when the emergency recording button is pressed on the live screen.)
- ▶ 1MIN, 2MIN, 3MIN, 4MIN, 5MIN, 10MIN

3 If you selected a JPEG stream in [RECORD STREAM], in [FRAME RATE], select the frame rate of the stream.

Select the refresh rate of live video.

- ▶ VCC-HD4600: 0.1ips, 0.2ips, 0.5ips, 1ips, 3ips, 5ips, 10ips, 15ips, 30ips
- ▶ VCC-HD4600P: 0.1ips, 0.2ips, 0.5ips, 1ips, 2.5ips, 5ips, 8ips, 12.5ips, 25ips

*** To configure the periods during which recording is activated, click **SCHEDULE**.**

The SCHEDULE SETTINGS screen appears.

For details, refer to the “SCHEDULE SETTINGS” section.



This button is labeled “SCHEDULE ON” if the recording schedule has been configured.

SD/HDD

Click **SD/HDD** button in the configuration menu to display the SD/HDD screen.

If you install a recording medium such as SD memory card or external hard disk drive on the camera, you can record video images and store log information in it.

To do so, install a recording medium on the camera and format it through this screen.



Required operation privilege: admin, operator1

Though the recording media can also be formatted via the SD/HDD SET screen on the camera, on this screen, you can configure the ratio of the recording areas.

In cases where both an SD memory card and an external hard disk drive are simultaneously connected, the hard disk drive takes precedence.

SETTING ITEMS	SET VALUE
SD MEMORY CARD	NO USE
LOG	OFF
AREA	NORMAL
	ALARM
SIZE/FORMAT	NO CARD
OVERWRITE	OFF
AUTO DELETE	OFF

SETTING ITEMS	SET VALUE
HDD	NO USE
LOG	OFF
AREA	NORMAL
	ALARM
SIZE/FORMAT	NO MEDIA
OVERWRITE	OFF
AUTO DELETE	OFF

1 In [SD MEMORY CARD] or [HDD], select “USE”.

If you are removing the SD card or hard disk drive from the camera, select “NO USE”.

2 To record log information, configure [LOG] to “ON”.

The log recording area is automatically configured so that approximately 16,000 access logs and 16,000 system logs can be stored respectively.



The recorded log information is retained even when the camera power is turned off.

3 In [AREA], allocate the storage areas.

- ▶ NORMAL (1 to 98): Recording area for normal video
- ▶ ALARM (1 to 98): Specify the recording area for alarm video and backup video in the event of a network failure.

4 In [SIZE/FORMAT], check that the storage capacity of the SD card (“4GB” for example) is shown.

This field shows “NO CARD/NO MEDIA” when the camera has no recording media installed and “FORMATTED” when it has a formatted medium.

5 Click **FORMAT** .

An operation confirmation dialog box opens. Click **OK** to start formatting the SD card.

When the format process is completed, you will notice that, in [SIZE/FORMAT], the label of the [FORMAT] button has been changed to **“FORMATTED”**.



Do not remove the recording medium while it is being formatted.

Configuring Overwrite Recording and Auto Delete Functions

OVERWRITE	OFF
AUTO DELETE	OFF

In [OVERWRITE], enable or disable the overwrite recording function.

- ▶ ON: Enables overwrite recording, in which the camera continues recording by sequentially overwriting the oldest recorded data if the recording area becomes full.
- ▶ OFF: Disables overwrite recording so that the camera stops recording if the recording area becomes full.



If recording stops because the recording area has become full, you can turn [OVERWRITE] to “ON”, or secure the recording space by deleting some recorded data, to restart recording.

In [AUTO DELETE], enable or disable the auto delete function.

- ▶ OFF, 1DAY, 2DAYS to 30DAYS

Use the auto delete function to automatically delete recorded data that has been stored for a long period. For example, setting this to “30DAYS” causes recorded data to be deleted automatically when 30 days have elapsed after recording.

5 Click **SET** .

The settings are saved. You are now ready to record video onto the SD memory card or external hard disk drive.

E-MAIL SETTINGS

Click **E-MAIL** in the configuration menu to display the E-MAIL SETTINGS screen.

Using the automatic e-mail transmission function, you can send an e-mail attached with an image if an alarm is detected, or after a fixed interval.

- A** Configuring basic e-mail transmission settings
- B** Configuring recipient e-mail addresses (RECIPIENT MAIL ADDRESS)
- C** Configuring authentication conditions (AUTHENTICATION)
- D** Configuring transmission conditions
- E** Configuring e-mail text (SUBJECT/TEXT)

Log information display area (LOG): In [LOG], you can view the SMTP (e-mail) transmission log.



Required operation privilege: admin, operator1

You can send JPEG images only.



For network-related settings, consult your network administrator.

A Configuring basic e-mail transmission settings

SETTING ITEMS	SET VALUE
E-MAIL	OFF
SSL	OFF
SMTP SERVER ADDRESS	
SMTP PORT NUMBER	25
USER MAIL ADDRESS	

1 In [E-MAIL], select “ON” to enable the e-mail transmission function.

2 In [SSL], select “ON” to use SSL communication.

If your e-mail server supports SSL, you can encrypt e-mail transmission.

3 Configure your e-mail server.

Type the following information on your e-mail server.

A SMTP SERVER ADDRESS

Type the address of your SMTP server (up to 64 alphanumeric characters).

B SMTP PORT NUMBER

Type the incoming port number of your SMTP server.

The available port numbers are 0 to 65535.



Normally, use the default value “25”. However, if you are using the submission port for security reasons or in other cases where you need to do so, change the default value.

4 In [USER MAIL ADDRESS], type the sender's e-mail address and click **SET**.

Here, you can type only one e-mail address (up to 64 alphanumeric characters).

B Configuring recipient e-mail addresses (RECIPIENT MAIL ADDRESS)

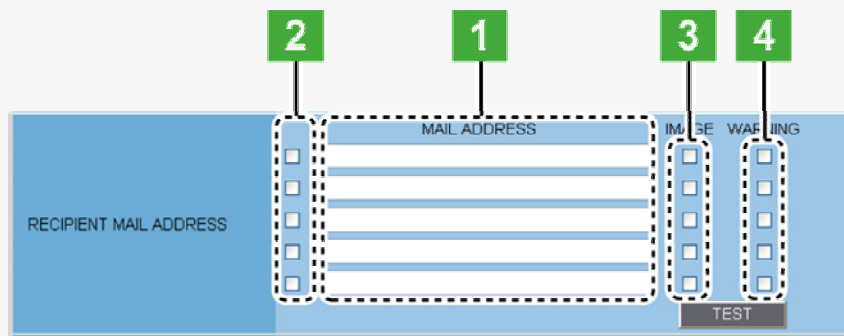

1 In [MAIL ADDRESS], type the recipient e-mail addresses.

Here, you can type up to five e-mail addresses (up to 64 alphanumeric characters for each).

2 Select the check box for each e-mail address to which you want to send e-mails.

You can send e-mails to the selected e-mail address(es).

3 Select the [IMAGE] check box for the recipient address if you want to attach an image file to each e-mail.



The attached image file will have the following file name:
CAMERA ID + _yymmddhhmmss.jpg

CAMERA ID is the leading four characters of the camera title. However, any of the following symbols, if included, will be replaced by a "-" (hyphen):

/ (slash), \ (backslash), ? (question mark), * (asterisk), : (colon), ; (semicolon), ' (single quote), " (double quote), < (less-than sign), > (greater-than sign), | (broken bar)

4 To send a warning e-mail automatically in the event of a failure, select the [WARNING] check box and click **SET**.

A warning e-mail will be sent in any of the following cases:

- When an SD card error occurs,
- When the remaining recording area is reduced to the warning level (20%/10%),
- When recording was stopped because the remaining recording area had been used up, or
- When a power failure occurs, or the system recovers from a power failure.

* To send a test e-mail, click **TEST**.

A test e-mail is sent to each recipient e-mail address for which you selected the check box in Step 2.



The subject (SUBJECT) of this test e-mail will be "TEST".

C Configuring authentication conditions (AUTHENTICATION)

To perform an authentication check, you need to configure the authentication conditions.

1 In [AUTHENTICATION], select the authentication method.

- ▶ NO USE, POP3, SMTP

2 In [USER ID] and [PASSWORD], type the user ID and password, respectively.

Type the user ID (up to 48 alphanumeric characters) and password for authentication (up to 20 alphanumeric characters).

3 In [POP3 SERVER ADDRESS], type your POP3 server address and click **SET**.

If you selected “POP3” in [AUTHENTICATION], type the IP address or domain name of your POP3 server (up to 64 alphanumeric characters).

D Configuring transmission conditions

TRIGGER	NETWORK FAILURE
NETWORK FAILURE TIME	15SEC
INTERVAL	1MIN
JPEG IMAGE	OFF

1 In [TRIGGER], select the e-mail transmission conditions.

- ▶ **INTERVAL:** Sends an e-mail at fixed intervals.
- ▶ **ALARM IN1:** Sends an e-mail when the ALARM IN1 terminal receives an alarm signal.
- ▶ **ALARM IN2:** Sends an e-mail when the ALARM IN2 terminal receives an alarm signal.
- ▶ **MOTION:** Sends an e-mail when the motion sensor detects motion in the subject.
- ▶ **ALARM OUT1:** Sends an e-mail when the ALARM OUT 1 terminal outputs an alarm signal.
- ▶ **ALARM OUT2:** Sends an e-mail when the ALARM OUT 2 terminal outputs an alarm signal.
- ▶ **NETWORK FAILURE:** Sends an e-mail when the camera detects a network failure during network recording.

A If you selected “NETWORK FAILURE” ...

In [NETWORK FAILURE TIME], select the time from the occurrence of a network failure until the camera recognizes it as a recording trigger.

- ▶ 15SEC, 20SEC, 30SEC, 40SEC, 50SEC, 1MIN, 2MIN, 3MIN, 4MIN, 5MIN



The setting values are interlocked among RECORDING, E-MAIL SETTINGS, and FTP SETTINGS screens. (Note that the setting configured most recently will take precedence.)

B If you selected “INTERVAL” ...

In [INTERVAL], select the interval between e-mail transmissions.

- ▶ 1MIN, 2MIN, 3MIN, 4MIN, 5MIN, 10MIN, 15MIN, 30MIN, 1HOUR, 2HOUR, 3HOUR, 4HOUR, 5HOUR, 6HOUR, 7HOUR, 8HOUR, 12HOUR, 24HOUR

2 To attach an image file to each e-mail, in [JPEG IMAGE], select a JPEG stream option and click **SET**.

You can attach JPEG images only.

▶ OFF (No attachment), STREAM1, STREAM2, STREAM3, STREAM4



The pull-down menu shows a list of streams for which you selected “JPEG” in [CODEC] on the VIDEO & AUDIO SETTINGS screen. A warning message will appear if there is no JPEG stream available.

E Configuring e-mail text (SUBJECT/TEXT)

Here, configure the subject and message text portions of the e-mail.

SUBJECT	<input type="text"/>
TEXT	<input type="text"/>
LOG	



An e-mail consists of the following portions.

- Subject
- Camera Title
- Data and time
- Camera's IP address
- Message (TEXT)

The camera title, date and time, IP address will be included automatically.

1 In [SUBJECT], type the subject (title) of the e-mail.

You can type up to 32 alphanumeric characters.

2 In [TEXT], type the message text and click **SET**.

You can type up to 64 alphanumeric characters.



In the [SUBJECT] and [TEXT] fields, you can use special symbol characters.

FTP SETTINGS

Click **FTP** in the configuration menu to display the FTP SETTINGS screen.

If you want to record images from the camera to an FTP server via the network, configure the FTP server settings and the image transmission conditions on this screen.

A Configuring FTP server settings

B Configuring transmission conditions



Required operation privilege: admin, operator1

You can send JPEG images only.

A Configuring FTP Server Settings

1 In [FTP], select “ON”.

SETTING ITEMS	SET VALUE
FTP	ON
PORT NUMBER	21
SERVER ADDRESS	
USER ID	
PASSWORD	

2 In [PORT NUMBER], type the control port number configured on the server.

Type a number between 1 and 65535. This port number is normally “21” (default).

3 In [SERVER ADDRESS], type the server address. Then, in [USER ID] and [PASSWORD], type the user ID and password, respectively.

The number of characters you can type in these fields is as follows.

SERVER ADDRESS: Up to 64 alphanumeric characters

USER ID: Up to 48 alphanumeric characters

PASSWORD: Up to 20 alphanumeric characters

4 To use the passive FTP mode, in [FTP PASSIVE], select “USE”.

FTP PASSIVE	NO USE
DIRECTORY NAME	
FILE NAME	
TEMPORARY FILE	NO USE



When [FTP PASSIVE] is set to “USE”, users must specify a valid port number when making a connection request for sending data to the server.

5 In [DIRECTORY NAME], specify the name of the directory you want to create on the server.

You can type up to 32 alphanumeric characters.



If no directory name is specified, the system will automatically generate the following directory name.

When sending an alarm image in the event of an error: **ALARM_FTP**

When sending an image in fixed intervals: **INTERVAL_FTP**

6 In [FILE NAME], specify the name of the image file you want to send and click **SET**.

You can type up to 32 alphanumeric characters.



Each image file will have a file name consisting of the specified file name, the date/time, and the alarm factor (if [TRIGGER] is set to other than "INTERVAL"):

[FILE NAME] + [yy_mm_dd_hh_mm_ss] + [alarm_factor] + [0001 (Serial No.)].jpg

If no file name is specified, the system will enter "sanyo" for the [FILE NAME].

*** To use a temporary file, set [TEMPORARY FILE] to "USE".**

This causes each image to be stored as a temporary file on the FTP server and then renamed to the specified file name.

The FTP server will store a single temporary file for the most recent image with the specified file name.



Temporary file name: sanyo_ftp_temp_[IP address].temp

Although the temporary file will be renamed to the specified file name and then stored in the specified directory as explained in steps **5** to **6**, the renamed file name will not include the date/time and alarm factor information.

Both the temporary and permanent files will be overwritten if the same file name exists.

B Configuring transmission conditions

1 In [TRIGGER], select the image transmission trigger condition.

The setting items you are required to configure are displayed in accordance with the selected trigger condition.

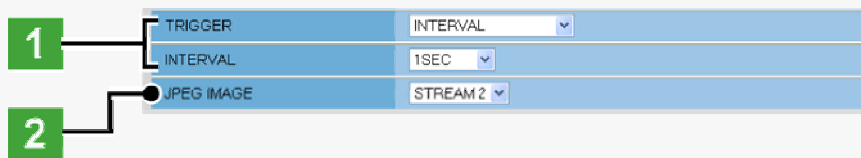

- ▶ **INTERVAL:** Sends a still image in fixed intervals.
- ▶ **ALARM IN1:** Sends a still image when the ALARM IN1 terminal receives an alarm signal.
- ▶ **ALARM IN2:** Sends a still image when the ALARM IN2 terminal receives an alarm signal.
- ▶ **MOTION:** Sends a still image when the motion sensor detects motion in the subject.
- ▶ **ALARM OUT1:** Sends a still image when the ALARM OUT 1 terminal outputs an alarm signal.
- ▶ **ALARM OUT2:** Sends a still image when the ALARM OUT 2 terminal outputs an alarm signal.
- ▶ **NETWORK FAILURE:** Sends a still image when the camera detects a network failure during network recording.



You need to configure the alarm input/output conditions on the ALARM SETTINGS screen.

A If you selected "NETWORK FAILURE" ...

In [NETWORK FAILURE TIME], select the time from the occurrence of a network failure until the camera recognizes it as a recording trigger.

- ▶ 15SEC, 20SEC, 30SEC, 40SEC, 50SEC, 1MIN, 2MIN, 3MIN, 4MIN, 5MIN



The setting values are interlocked among RECORDING, E-MAIL SETTINGS, and FTP SETTINGS screens. (Note that the setting configured most recently will take precedence.)

B [DURATION] setting in case you selected “ALARM IN1/2”, “MOTION”, “ALARM OUT1/2”, or “NETWORK FAILURE”

In [DURATION], select the image transmission duration.

- ▶ 5SEC, 10SEC, 20SEC, 40SEC, 1MIN, 2MIN, 3MIN, 4MIN, 5MIN, 10MIN, 15MIN

C Common setting (INTERVAL)

In [INTERVAL], select the interval between e-mail transmissions.

- ▶ 1SEC, 2SEC, 3SEC, 5SEC, 10SEC, 30SEC, 1MIN, 3MIN, 5MIN, 10MIN, 15MIN, 30MIN, 1HOUR, 2HOUR, 3HOUR, 4HOUR, 5HOUR, 6HOUR, 8HOUR, 12HOUR, 24HOUR



If you selected “ALARM IN1/2”, “MOTION”, “ALARM OUT1/2”, or “NETWORK FAILURE”, only “1SEC-15MIN” is displayed as an option.

In [INTERVAL], the pull-down menu will only show options that do not exceed the [DURATION] setting.

2 In [JPEG IMAGE], select the JPEG stream you want to send and click **SET.**

You can send JPEG images only.



You need to configure the video conditions for each stream on the VIDEO & AUDIO SETTINGS screen.

The pull-down menu shows a list of streams for which you selected “JPEG” in [CODEC] on the VIDEO & AUDIO SETTINGS screen.

A warning message will appear if there is no JPEG stream available.

SECURITY SETTINGS

Click **SECURITY** in the configuration menu to display the SECURITY SETTINGS screen.

Configuring the security function on this screen enables you to restrict the PCs that can access the camera.



Required operation privilege: admin, operator1

1 In **[SECURITY FUNCTION]**, select “ON”.

2 In **[DEFAULT POLICY]**, select the global access policy.

Here, you specify the access policy for all PCs, except for those for which you configure the access settings in **[NETWORK ADDRESS/SUBNET]** (**3**).

<Global access policy>

▶ **REJECTED**: Rejects access to the camera.

▶ **AUTHORIZED**: Permits access to the camera.

SETTING ITEMS	SET VALUE
SECURITY FUNCTION	<input type="radio"/> OFF <input checked="" type="radio"/> ON
DEFAULT POLICY	AUTHORIZED

3 In **[NETWORK ADDRESS/SUBNET]**, configure the access settings for individual PCs.

Type the IP address and the subnet mask of each PC and specify whether or not to grant it access to the camera. You can configure the access settings for up to 10 PCs.

<Individual access policy>

▶ **REJECTED**: Rejects access to the camera.

▶ **AUTHORIZED**: Permits access to the camera.



If there are duplicate address/subnet mask settings, one in the uppermost row is valid.

Example 1: When the global access policy (DEFAULT POLICY) is set to “AUTHORIZED” and the individual access policy is set to “REJECTED”

The PCs configured in **[NETWORK ADDRESS/SUBNET 1]** and **[NETWORK ADDRESS/SUBNET 2]** cannot access the camera because their individual access policy is “REJECTED”.

SETTING ITEMS	SET VALUE
SECURITY FUNCTION	<input type="radio"/> OFF <input checked="" type="radio"/> ON
DEFAULT POLICY	AUTHORIZED
NETWORK ADDRESS / SUBNET1	192 . 168 . 0 . 20 / 32 REJECTED
NETWORK ADDRESS / SUBNET2	192 . 168 . 0 . 200 / 32 REJECTED

Example 2: When the global access policy (DEFAULT POLICY) is set to “REJECTED” and the individual access policy is set to “AUTHORIZED” ...

The PCs configured in **[NETWORK ADDRESS/SUBNET 1]** and **[NETWORK ADDRESS/SUBNET 2]** can access the camera because their individual access policy is “AUTHORIZED”.

SECURITY FUNCTION	<input type="radio"/> OFF <input checked="" type="radio"/> ON				
DEFAULT POLICY	REJECTED				
NETWORK ADDRESS / SUBNET1	192	168	0	1	/ 32 AUTHORIZED
NETWORK ADDRESS / SUBNET2	192	168	0	100	/ 32 AUTHORIZED

4 Click **SET**.

The settings are saved.



An error message will appear on PCs that fail to access the camera due to the above settings.

SCHEDULE SETTINGS

Click **SCHEDULE** in the configuration menu to display the SCHEDULE SETTINGS screen.

On this screen, you can schedule the time periods during which recording is activated if you intend to record video on the SD memory card installed in the camera.

A Configuring a recording schedule (SCHEDULE)

B Defining your holidays (HOLIDAY SETTINGS)



Required operation privilege: admin, operator1

To directly display this screen, click **SCHEDULE** on the RECORDING screen.

A Configuring a Recording Schedule

Configure the alarm recording schedule and normal recording schedule individually.

1 In [SCHEDULE], select "ON".

SCHEDULE SETTINGS		HELP
SETTING ITEMS	SET VALUE	
SCHEDULE	ON	

2 Configure the recording periods.

You can define a recording period of up to 24 hours in each line.

Configuring the recording period for each day of the week

Select the check box for the desired day of the week and, in [START] and [END], specify the start and end time of the recording.

<Example>

NORMAL RECORDING	START	END
<input checked="" type="checkbox"/> SUN	01 : 00	SUN 19 : 00

→ Configuring the camera to start recording at 1:00 and end recording at 19:00 every Sunday (18 hours)

<Example 2>

Select the desired day of the week and specify the start and end times of the recording. If the end time is before the start time, the system considers that the period extends to the next day and thus changes the day of the week indication in the [END] column to the next day.

NORMAL RECORDING	START	END
<input checked="" type="checkbox"/> SUN	01 : 00	MON 00 : 50

→ Configuring the camera to start recording at 1:00 every Sunday and end recording at 0:50 on next Monday (23 hours 50 minutes)

Configuring the same recording period every day

Select the [DAILY] check box in the lowest line and, in [START] and [END], specify the start and end times of the recording.

<Example 3>

DAILY 13 : 00 — 23 : 30

→ Configuring the camera to start recording at 13:00 and end recording at 23:30 every day (10 hours 30 minutes every day)

3 Select the check box next to the recording period (day) you want to apply and click **SET** .

The schedule map appears, showing the recording period you configured for each day of the week and enabled by selecting the check box.

If both the check box for a day of the week (SUN to SAT) and the “DAILY” check box are selected, the “DAILY” setting will take precedence.

- Normal recording: Blue
- Alarm recording: Orange

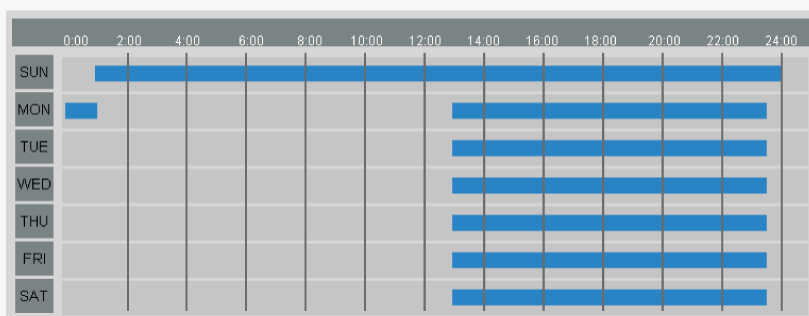

On the schedule map, each recording period will be indicated in units of 15 minutes.

If you have changed the schedule settings, be sure to click **SET** to update the schedule map.

If you change the scheduled settings while the schedule is enabled, the camera will perform recording according to the changed schedule.

If you schedule overlapping recording periods, the longer one will take precedence.

If the configured periods overlap as shown below, they will be combined into one long period.

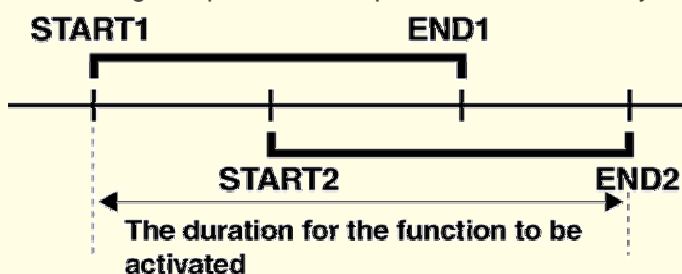

B Defining Your Holidays

Follow the steps below to define your holidays.

1 Click **HOLIDAY** .

The HOLIDAY SETTINGS screen appears.

2 In **[HOLIDAY]**, select the day of the week that you want to define as a weekly holiday.

3 In **[MONTH/DAY]**, select the day of the year that you want to define as an annual holiday.

To each day of the year configured here, the same operation schedule as that for the weekly holiday setting in **[HOLIDAY]** will be applied.

You can define up to 20 annual holidays.

Example: Defining July 18 as an annual holiday, in addition to weekly holidays (Mondays) defined in [HOLIDAY]

HOLIDAY SETTINGS	
HOLIDAY	
MON	
MONTH / DAY	MONTH / DAY
1 JUL / 18	6 - / -
2 - / -	7 - / -

4 Click **SET** and then **BACK** .

The setting is saved and the HOLIDAY SETTINGS section disappears.

OPTION SETTINGS

Click **OPTION** in the configuration menu to display the OPTION SETTINGS screen.
On this screen, you can perform system-related operations and log checks.
Click **SET** to execute or start the intended operation.



Required operation privilege: admin, operator1

OPTION SETTINGS HELP

SYSTEM

POWER LED(FRONT)	OFF
ERROR LED(FRONT)	OFF
STABILIZER	OFF
LEVEL	MIDDLE

CAMERA REBOOT	<input type="button" value="SET"/>
FIRMWARE UPDATE	CAM MAIN Ver. 0.00-01 (090908-07) CAM SUB Ver. 0.00-01 (090909-00) NET MAIN Ver. 0.00-00 (090930-12) NET SUB Ver. 0.00-00 (090907-00) <input type="button" value="SET"/>
FACTORY DEFAULT	<input type="button" value="SET"/> WITH NETWORK SETTINGS
MENU BACK UP	<input type="button" value="SET"/>
MENU UPLOAD	<input type="text" value="Browse..."/> <input type="button" value="SET"/>
COPY RECORDING AREA SETTINGS <input type="button" value="OFF"/>	

LOG

ACCESS LOG	<input type="button" value="OUTPUT"/>
SYSTEM LOG	<input type="button" value="OUTPUT"/>

Configuring the Indicator

You can enable/disable the indicator on the front face of the camera. The indicator indicates the power supply status (by lighting up) and the error status (by blinking).

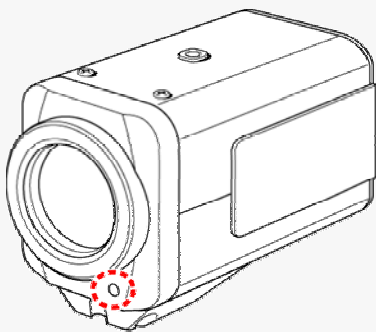

POWER LED(FRONT)	OFF
ERROR LED(FRONT)	OFF

- POWER LED (FRONT)
- ERROR LED (FRONT)

Correcting the Sway of the Camera (STABILIZER)

Corrects automatically blurring images from a camera installed on a pillar, pole, wall or the like that is subject to shake.

Select "ON" and specify a correction level for the sway of the camera in [LEVEL].

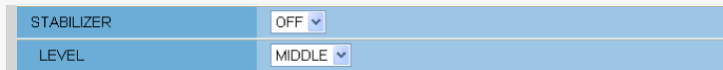

STABILIZER	OFF
LEVEL	MIDDLE

▶ LOW, MIDDLE, HIGH



As the compensation level increases, the resolution of image during sway compensation lowers, and the angle of view becomes slightly narrower.

The correction function will not work in the following condition.

- Switching between the color and the black-and-white modes is taking place by means of the DAY/NIGHT function.

- When the menu screen is displayed

- For one minute after the camera is powered on

Beside the conditions above, the correction function may not work depending on the sway level or cycle.

Rebooting Camera (CAMERA REBOOT)

If the camera stops functioning for some reason or other, in [CAMERA REBOOT], click **SET** to reboot the camera system.

Updating Firmware Version (FIRMWARE UPDATE)

You can update the camera's firmware to the latest version.

1 Click **SET**.

The FIRMWARE UPDATE screen appears.



FIRMWARE UPDATE

FILE NAME:

2 Click **BROWSE** and select the firmware updater file.

3 Click **EXECUTE**.

The firmware update process starts. When the update process is completed, the camera system reboots and you reconnect to the camera automatically.

Once you reconnect to the camera, redisplay the OPTION SETTINGS screen and confirm that the firmware version has been updated.



Do not perform any operations on the screen or turn off the camera until the firmware update process is completed.

While the firmware is being updated, all camera functions stop working temporarily.

You cannot update the firmware while the camera is recording. In this case, an operation confirmation dialog box will open.

Restoring Factory Default Settings (FACTORY DEFAULT)

You can restore all the settings you have configured to the factory default settings.



In [NETWORK SETTINGS], select whether or not to restore the settings including the network settings and click **SET**.

- ▶ **WITH:** Includes the network settings.
- ▶ **WITHOUT:** Excludes the network settings.

An operation confirmation dialog box opens.

Backing Up Configured Settings (MENU BACKUP)

You can save the settings you have configured using the backup function.



In [MENU BACKUP], click **SET**. Then, select **SAVE** in a save confirmation dialog box and specify the backup destination file.



All the settings on the NETWORK SETTINGS screen and the [DATE/TIME] setting on the CLOCK SETTINGS screen are not saved.

Uploading Backed Up Settings (MENU UPLOAD)

You can restore the saved configuration settings of the camera from a backup file.

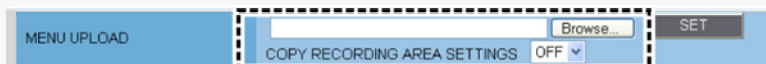

1 In [COPY RECORDING AREA SETTINGS], select whether or not to restore the settings including the recording area settings.

- ▶ **WITH:** Includes the [AREA] settings configured on the SD/HDD screen.
- ▶ **WITHOUT:** Excludes the [AREA] settings configured on the SD/HDD screen.

2 Click **BROWSE**, select the backup file you want to upload, and click **SET**.

The backup file is uploaded to the camera to restore the saved configuration settings.

When the upload process is completed, the camera system reboots.



All the settings on the NETWORK SETTINGS screen and the [DATE/TIME] setting on the CLOCK SETTINGS screen are not restored.

Viewing Logs (LOG)

Under [LOG], you can view the access and system logs.

You can click **OUTPUT** to output the content of each log into a text file.



Logged information will be cleared when you turn off the camera. Save the logs to an SD memory card, if necessary.



A ACCESS LOG

Shows the history of access to the camera in chronological order (up to 100 entries).

- ▶ Date and time, user name, authentication check result (OK/NG), connection destination IP address

B SYSTEM LOG

Shows a history of system operations and errors in chronological order (up to 200 entries).



VCC-HD4600/HD4600P

Chapter 6

Q&A

Accessing the Camera
Control Panel/Tool Panel
CAMERA SETTINGS
Displaying LIVE video
Transmitting Image Data
Recording
Others

Accessing the Camera



I cannot access the camera.



- 1 The camera IP address you entered is wrong.
 - ▶ Enter the correct IP address (URL) in the Web browser (Internet Explorer).
- 2 The camera port number you entered is wrong.
 - ▶ If you are using a port number other than 80, enter the correct port number in the Web browser (Internet Explorer).
- 3 You have accessed with "http://" where you should be using HTTPS.
 - ▶ When using HTTPS, access with "https://". Also make sure to enter the port number if you have changed it to other than 443.
- 4 Access is restricted by security setting (The error message "403 forbidden" is displayed).
 - ▶ Contact your network administrator and ask him/her to change the security settings.



I cannot access the camera from within my home/company network.



- 1 The PC and camera IP addresses (local addresses) are configured with different subnet masks.
 - ▶ To use a PC and a camera within the same network, their subnet masks must be the same. Change settings so that the PC and camera have the same subnet mask.
- 2 The Web browser you are using is configured to connect to the Internet via proxy server.
 - ▶ Change the Web browser settings so that the use of proxy server is disabled.
- 3 The address you are trying to access is not a local address.
 - ▶ Enter a local address to access a camera located in the same network.
 - ▶ You cannot access a camera by entering a URL (or router global address and camera port number) registered with the dynamic DNS service or a URL that is compliant with the global address.



I cannot access the camera from the Internet.



- 1 There is a wrong network setting in the camera.
 - ▶ Configure the default gateway correctly. When using the dynamic DNS service, check whether the entered DNS server address and domain name registered with the dynamic DNS service are correct.
- 2 Registration to the dynamic DNS service is yet to be done. (When using the dynamic DNS service)
 - ▶ Go to the dynamic DNS service site and check that the address for your camera is correctly registered.
- 3 Port forwarding is not configured on your router.
 - ▶ Port forwarding must be configured on your router for you to be able to access a camera from the Internet. For the configuration method, refer to your router's instruction manual.

- 4 Your router is configured with packet filtering or the like which restricts access from the Internet.
 - ▶ Change the settings in your router to allow access from the Internet. For the configuration method, refer to your router's instruction manual.
- 5 The IP address you entered is a local address (the one you use at your home).
 - ▶ When accessing via Internet, enter the global address (or the URL registered with the DDNS service) and port number of the camera as its IP address.



The camera has been suddenly disconnected.



- 1 Another user has changed the password.
 - ▶ Configure the password settings again.
- 2 Another user has changed the camera settings.
 - ▶ Access again after a while.



I get stuck at the Login screen.



- 1 The password is changed.
 - ▶ Check the password and try again.



The access lamp does not go on.



- 1 The LAN cable that connects directly to the camera is broken.
 - ▶ Connect the LAN cable.
- 2 The LAN cable has been unplugged.
 - ▶ Connect the LAN cable.
- 3 The switching hub is turned off.
 - ▶ Turn on the switching hub.



I forgot the camera IP address/port number.



- ▶ Display the menu screen by pressing the SET button on the camera, and confirm the settings on the NETWORK SET screen.
- ▶ Use the supplied software "Auto IP Setup" to search for your camera information.

Control Panel/Tool Panel



Buttons on the control panel/tool panel do not respond.



1 You do not have the required operation privilege.

- ▶ Some buttons on the control panel/tool panel are operable only when you have an adequate operation privilege. Log in as a user with an adequate operation privilege.

2 You have not configured the required operation settings.

- ▶ The audio controls on the tool panel are operable only when you have configured the audio settings on the CLIENT SETTINGS screen.
- ▶ The [DIGITAL PTZ] button is not operable when you have set [DIGITAL PTZ] to "OFF" on the VIDEO & AUDIO SETTINGS screen.
- ▶ The remote alarm button is operable only when you have set the [ALARM OUT] on the ALARM SETTINGS screen to "REMOTE".



The [MENU] button does not respond.



Only the admin and operator1 users have the operation privilege for the configuration screens.

- ▶ Without the required operation privilege, you will be presented with an authentication check dialog box when you click the [MENU] button on the live screen.

In this case, you can change the operation privilege by entering a user name with an adequate operation privilege and its password in the dialog box.



The camera responds to neither focus nor zoom operation.



Communication between the camera and the PC is down.

- ▶ Click the [Refresh] button on your Web browser and check that the live image is updated. Thereafter, perform the focus and/or zoom operation.



I cannot use the preset functions.



Communication between the camera and the PC is down.

- ▶ Click the [Refresh] button on your Web browser and check that the live image is updated. Thereafter, perform the focus and/or zoom operation.

CAMERA SETTINGS

Q

I cannot set [SHUTTER] to "SHORT" or "LONG".

A

■ You cannot configure the electronic shutter settings if you have set [SENSE UP] in [IRIS].
▶ Set [SENSE UP] in [IRIS] to "OFF".

Q

I cannot turn off the AGC.

A

- 1 You cannot set [AGC] to "OFF" when [DAY/NIGHT] is set to "AUTO".
▶ Set [DAY/NIGHT] to "COLOR" or "B/W".
- 2 You cannot set [AGC] to "OFF" when [SENSE UP] in [IRIS] is set to "ON".
▶ Set [SENSE UP] in [IRIS] to "OFF".

Displaying LIVE video



I cannot display LIVE video.



1 ActiveX control is not installed in your PC.

▶ Install ActiveX.

2 There is network congestion.

▶ It may take some time until the screen can be displayed. Please wait.

▶ The message "THE UNIT IS BUSY" appears on the screen if the number of simultaneously accessible users is already reached.

3 The version of the installed ActiveX control is old.

▶ When another ActiveX control for network cameras is installed, video may not be displayed due to compatibility issues between the different versions. Install the H.264 Plug-In included in the supplied CD-ROM or the latest H.264 Plug-In you can download from SANYO CCTV System Web page.

4 The Web browser you are using for accessing the camera is configured to connect to the Internet via proxy server.

▶ Some proxy servers block UDPs during H.264 browsing. In this case, either change the settings to browse H.264 using HTTP, or browse using JPEG.



I cannot install the "H.264 Plug-In" included in the supplied CD-ROM.



1 The OS of your PC is not a recommended OS.

▶ The OS must be Windows Vista, Windows XP Home Edition or Windows XP Professional SP2 or later for the H.264 Plug-In to run.

2 You are not logged into the PC with administrator privileges.

▶ To install the H.264 Plug-In in a PC, you need OS administrator privileges. If you are logged in with user privileges, log out and log in again with administrator privileges to do the installation.



An error code appears and no LIVE video is displayed.



1 The configured IP address or domain name is wrong.

▶ Configure the IP address or domain name correctly.

2 If the address or domain name is correct, then the network connection has timed out.

▶ Use the network when it is not congested, or check whether there are other applications using the network and if there are, stop them for example.



The screen has suddenly stopped refreshing.



1 A camera power or network fault has occurred.

▶ Check the power supply status and/or the network environment.



The video image is distorted and cannot be displayed correctly.



1 The maximum bit rate for video streaming is configured with a value higher than the network bandwidth.

▶ Lower the resolution and/or image quality.

2 The performance of the PC is low.

▶ Make sure that your PC meets the operation requirements specified in the “Operating Environment” section.

Or replace the video card in the PC with another with higher performance.



The image quality is bad.



1 The color quality for your PC monitor is configured to less than 16 bits.

▶ On the [Display Properties] -[Settings] tab, configure the [Color quality] setting for your PC to 16 bits or more.



The recording rate is low or the video stops temporarily.



1 Among the multiple accesses to the camera, some are from narrowband networks.

▶ Change the minimum bit rate for video streaming to a large value.

2 There are multiple accesses or accesses with request for multiple resolutions.

▶ Increasing the number of accesses or simultaneous streamings with different resolutions may decrease the recording rate and/or image quality. Lower the resolution, image quality, and/or recording rate.



The recording rate is low at maximum resolution.



1 The performance of the PC is low.

▶ Make sure that your PC meets the operation requirements specified in the “Operating Environment” section.

Or replace the video card in the PC with another with higher performance.



The LIVE video image is not clear.



1 [FOCUS] for CAMERA is set to [AUTO].

▶ Adjust after setting to [MANUAL].

2 [FOCUS] for CAMERA is set to [MANUAL].

▶ Change it to [AUTO].

3 The object is too close to the camera.

▶ Move away the object from the camera.

4 Dust, dirt, fingerprints, etc. are present on the lens cover. Or the lens is fogged.

▶ Wipe away the dust, etc. with a dry cloth.

Q

The live video display is entirely discolored (A white subject appears to be colored.)

A

■ Adjust the white balance.

▶ Click [WHITE BALANCE] on the CAMERA SETTINGS screen and, in [WHITE BALANCE], select "MWB". Then, adjust the white balance so that a white subject appears to be white.

Q

The LIVE video image is noisy.

A

1 The background of the object is dark.

▶ Increase the lighting to the monitored environment.

Alternatively, in [DAY/NIGHT] on the CAMERA SETTINGS screen, select [AUTO] to enable the [DAY/NIGHT] mode.

2 The color quality for your PC monitor is configured to less than 16 bits.

▶ On the [Display Properties] -[Settings] tab, configure the [Color quality] setting for your PC to 16 bits or more.

Q

The image contains white spots or colored light spots.

A

■ You are using the camera in a dark place. Or, you are recording a dark object.

▶ White spots or colored light spots may appear on the screen when the camera is used in a dark place or monitoring a dark subject. This is a characteristic of the image pickup device and is not a malfunction. Use auxiliary lighting or some other means to illuminate the monitored environment.

Transmitting Image Data



The e-mail transmission function does not work.



1 On the E-MAIL SETTING screen, incorrect user ID/password information is specified in the AUTHENTICATION section.

▶ Set the correct login ID and password.

2 The server address is wrong. Or connection to the server is down.

▶ Check the server address settings.

3 The SMTP server requires authentication.

▶ If [AUTHENTICATION] is set to "NO USE", the e-mail transmission function does not work when the SMTP server requires authentication. Contact your network administrator and change the authentication setting according to the SMTP server setting.

This camera supports the two authentication methods, "SMTP" and "POP3 (POP before SMTP)".

4 Transfer is blocked by the "Outbound Port 25 Blocking (OP25B)*" implemented by your provider.

▶ Select the SMTP authentication for the camera and change the destination e-mail server port from 25 to 587.

▶ Use the destination e-mail server of your provider.

▶ Block e-mail transmission to the normally used port 25 to avoid mass-mailing junk e-mails to other providers' e-mail servers by by-passing your provider's e-mail server.



I cannot view the image data I received on my cell phone.



■ Some cell phones have a limit on the size of image data they can handle.

▶ Check the resolution of your cell phone.

Recording



The camera does not record.



1 A recording medium is not inserted or installed in the camera.

▶ Insert an SD memory card or install an external hard disk drive on the camera.

2 The recording medium is not formatted.

▶ Go to the SD/HDD screen, and format the recording medium.

3 Time elapsed from turning on the camera is less than 5 minutes.

▶ The system cannot recognize a recording medium for about 30 seconds after powered on.

▶ After turning on the camera, wait 5 minutes or more before starting to record.

4 The recording medium is write-protected.

▶ Cancel the protection in order to allow the recording medium for writing.

5 The USB cable for the hard disk drive is not connected properly.

▶ Turn off the HDD drive, re-insert the USB cable correctly and turn on the HDD drive again.

6 An installed recording medium was removed before writing was stopped.

▶ Format the recording medium. If you remove a recording medium while writing is in progress, you may damage it. Be sure to perform the following procedure to stop a writing operation before you remove the medium.

<Method for stop recording>

In [SD MEMORY CARD] or [HDD] on the SD/HDD screen, select "NO USE".

Or press the  and SET buttons on the side face of the camera simultaneously.



I cannot play back.



■ The camera is not equipped with playback functions.

▶ Install the supplied application software "HDC Downloader/ DLViewer" from the supplied CD-ROM. This application software will allow you to download and play back video data.



Upgrade has been terminated.



■ Upgrade has been interrupted due to power off, network fault, or other problem during the process.

▶ Redo the upgrade by proceeding as follows.

1 Turn on the camera again.

2 Access the camera again.

3 Check the firmware version on [FIRMWARE UPDATE] in OPTION SETTINGS screen.

* If the version number is updated: Upgrade is complete.

* If the version number is not updated: Redo the upgrade.



The date and time is not adjusted automatically by the NTP server.



1 Adjustment by NTP is not set as the method for automatic time adjustment.

▶ Select **CLOCK** and set [CLOCK ADJUST] to [ON (NTP)].

2 The NTP server address is not configured correctly.

▶ Select **CLOCK** and configure the [NTP SERVER ADDRESS] settings again.

3 The GATEWAY settings are not configured correctly.

▶ Select **NETWORK** and configure the [GATEWAY] settings again.



The date and time information indicated on the live screen does not reflect the clock settings configured on the [CLOCK SETTINGS] screen.



■ It is recommended that you delete temporary Internet files.

▶ To do so, in Internet Explorer, click [Internet Options] in the [Tools] menu and then delete temporary files, history, cookies, saved passwords, and web form information from the [General] tab.



VCC-HD4600/HD4600P

Chapter 7

Others

Copyright Notice
How to use this manual.

Copyright Notice

This instruction manual is copyrighted by SANYO Electric Co., Ltd. No materials contained in this manual may be reproduced in any format without the prior permission of the copyright holder.

Microsoft, Windows, ActiveX and Internet Explorer are registered trademarks or trademarks of Microsoft Corporation in the United States and other countries.

The official name for "Windows" used in this manual is Microsoft® Windows® Operating System. In this manual, note that the word "Windows" refers to both "Microsoft® Windows® XP Operating System" and "Microsoft® Windows® Vista Operating System".

Intel and Pentium are registered trademarks or trademarks of Intel Corporation and its subsidiaries in the United States and other countries.

IBM and IBM PC/AT are trademarks of International Business Machines Corporation.

HDMI, the HDMI Logo and High-Definition Multimedia Interface are trademarks or registered trademarks of HDMI Licensing LLC.

All other brands and product names in this manual are the registered trademarks or trademarks of their respective owners.

The SDHC Logo is a trademark.



OpenSSL License

The following license is applied to OpenSSL.

LICENSE ISSUES

=====

The OpenSSL toolkit stays under a dual license, i.e. both the conditions of the OpenSSL License and the original SSLeay license apply to the toolkit. See below for the actual license texts. Actually both licenses are BSD-style Open Source licenses. In case of any license issues related to OpenSSL please contact openssl-core@openssl.org.

OpenSSL License

/* =====

* Copyright (c) 1998-2008 The OpenSSL Project. All rights reserved.

*

* Redistribution and use in source and binary forms, with or without
* modification, are permitted provided that the following conditions
* are met:

*

* 1. Redistributions of source code must retain the above copyright
* notice, this list of conditions and the following disclaimer.

*

* 2. Redistributions in binary form must reproduce the above copyright
* notice, this list of conditions and the following disclaimer in
* the documentation and/or other materials provided with the
* distribution.

*

* 3. All advertising materials mentioning features or use of this
* software must display the following acknowledgment:

* "This product includes software developed by the OpenSSL Project

```

* for use in the OpenSSL Toolkit. (http://www.openssl.org/)"
*
* 4. The names "OpenSSL Toolkit" and "OpenSSL Project" must not be used to
* endorse or promote products derived from this software without
* prior written permission. For written permission, please contact
* openssl-core@openssl.org.
*
* 5. Products derived from this software may not be called "OpenSSL"
* nor may "OpenSSL" appear in their names without prior written
* permission of the OpenSSL Project.
*
* 6. Redistributions of any form whatsoever must retain the following
* acknowledgment:
* "This product includes software developed by the OpenSSL Project
* for use in the OpenSSL Toolkit (http://www.openssl.org/)"
*
* THIS SOFTWARE IS PROVIDED BY THE OpenSSL PROJECT ``AS IS'' AND ANY
* EXPRESSED OR IMPLIED WARRANTIES, INCLUDING, BUT NOT LIMITED TO, THE
* IMPLIED WARRANTIES OF MERCHANTABILITY AND FITNESS FOR A PARTICULAR
* PURPOSE ARE DISCLAIMED. IN NO EVENT SHALL THE OpenSSL PROJECT OR
* ITS CONTRIBUTORS BE LIABLE FOR ANY DIRECT, INDIRECT, INCIDENTAL,
* SPECIAL, EXEMPLARY, OR CONSEQUENTIAL DAMAGES (INCLUDING, BUT
* NOT LIMITED TO, PROCUREMENT OF SUBSTITUTE GOODS OR SERVICES;
* LOSS OF USE, DATA, OR PROFITS; OR BUSINESS INTERRUPTION)
* HOWEVER CAUSED AND ON ANY THEORY OF LIABILITY, WHETHER IN CONTRACT,
* STRICT LIABILITY, OR TORT (INCLUDING NEGLIGENCE OR OTHERWISE)
* ARISING IN ANY WAY OUT OF THE USE OF THIS SOFTWARE, EVEN IF ADVISED
* OF THE POSSIBILITY OF SUCH DAMAGE.
* =====
*
* This product includes cryptographic software written by Eric Young
* (eay@cryptsoft.com). This product includes software written by Tim
* Hudson (tjh@cryptsoft.com).
*
*/
Original SSLeay License
-----
/* Copyright (C) 1995-1998 Eric Young (eay@cryptsoft.com)
* All rights reserved.
*
* This package is an SSL implementation written
* by Eric Young (eay@cryptsoft.com).
* The implementation was written so as to conform with Netscapes SSL.
*
* This library is free for commercial and non-commercial use as long as
* the following conditions are aheared to. The following conditions
* apply to all code found in this distribution, be it the RC4, RSA,
* lhash, DES, etc., code; not just the SSL code. The SSL documentation
* included with this distribution is covered by the same copyright terms
* except that the holder is Tim Hudson (tjh@cryptsoft.com).
*
* Copyright remains Eric Young's, and as such any Copyright notices in
* the code are not to be removed.
* If this package is used in a product, Eric Young should be given attribution
* as the author of the parts of the library used.
* This can be in the form of a textual message at program startup or

```

* in documentation (online or textual) provided with the package.
*
* Redistribution and use in source and binary forms, with or without
* modification, are permitted provided that the following conditions
* are met:
* 1. Redistributions of source code must retain the copyright
* notice, this list of conditions and the following disclaimer.
* 2. Redistributions in binary form must reproduce the above copyright
* notice, this list of conditions and the following disclaimer in the
* documentation and/or other materials provided with the distribution.
* 3. All advertising materials mentioning features or use of this software
* must display the following acknowledgement:
* "This product includes cryptographic software written by
* Eric Young (eay@cryptsoft.com)"
* The word 'cryptographic' can be left out if the routines from the library
* being used are not cryptographic related :-).
* 4. If you include any Windows specific code (or a derivative thereof) from
* the apps directory (application code) you must include an acknowledgement:
* "This product includes software written by Tim Hudson (tjh@cryptsoft.com)"
*
* THIS SOFTWARE IS PROVIDED BY ERIC YOUNG ``AS IS'' AND
* ANY EXPRESS OR IMPLIED WARRANTIES, INCLUDING, BUT NOT LIMITED TO, THE
* IMPLIED WARRANTIES OF MERCHANTABILITY AND FITNESS FOR A PARTICULAR PURPOSE
* ARE DISCLAIMED. IN NO EVENT SHALL THE AUTHOR OR CONTRIBUTORS BE LIABLE
* FOR ANY DIRECT, INDIRECT, INCIDENTAL, SPECIAL, EXEMPLARY, OR CONSEQUENTIAL
* DAMAGES (INCLUDING, BUT NOT LIMITED TO, PROCUREMENT OF SUBSTITUTE GOODS
* OR SERVICES; LOSS OF USE, DATA, OR PROFITS; OR BUSINESS INTERRUPTION)
* HOWEVER CAUSED AND ON ANY THEORY OF LIABILITY, WHETHER IN CONTRACT, STRICT
* LIABILITY, OR TORT (INCLUDING NEGLIGENCE OR OTHERWISE) ARISING IN ANY WAY
* OUT OF THE USE OF THIS SOFTWARE, EVEN IF ADVISED OF THE POSSIBILITY OF
* SUCH DAMAGE.
*
* The licence and distribution terms for any publically available version or
* derivative of this code cannot be changed. i.e. this code cannot simply be
* copied and put under another distribution licence
* [including the GNU Public Licence.]
*/

How to use this manual.

Window Layout

This manual consists of three resident windows:

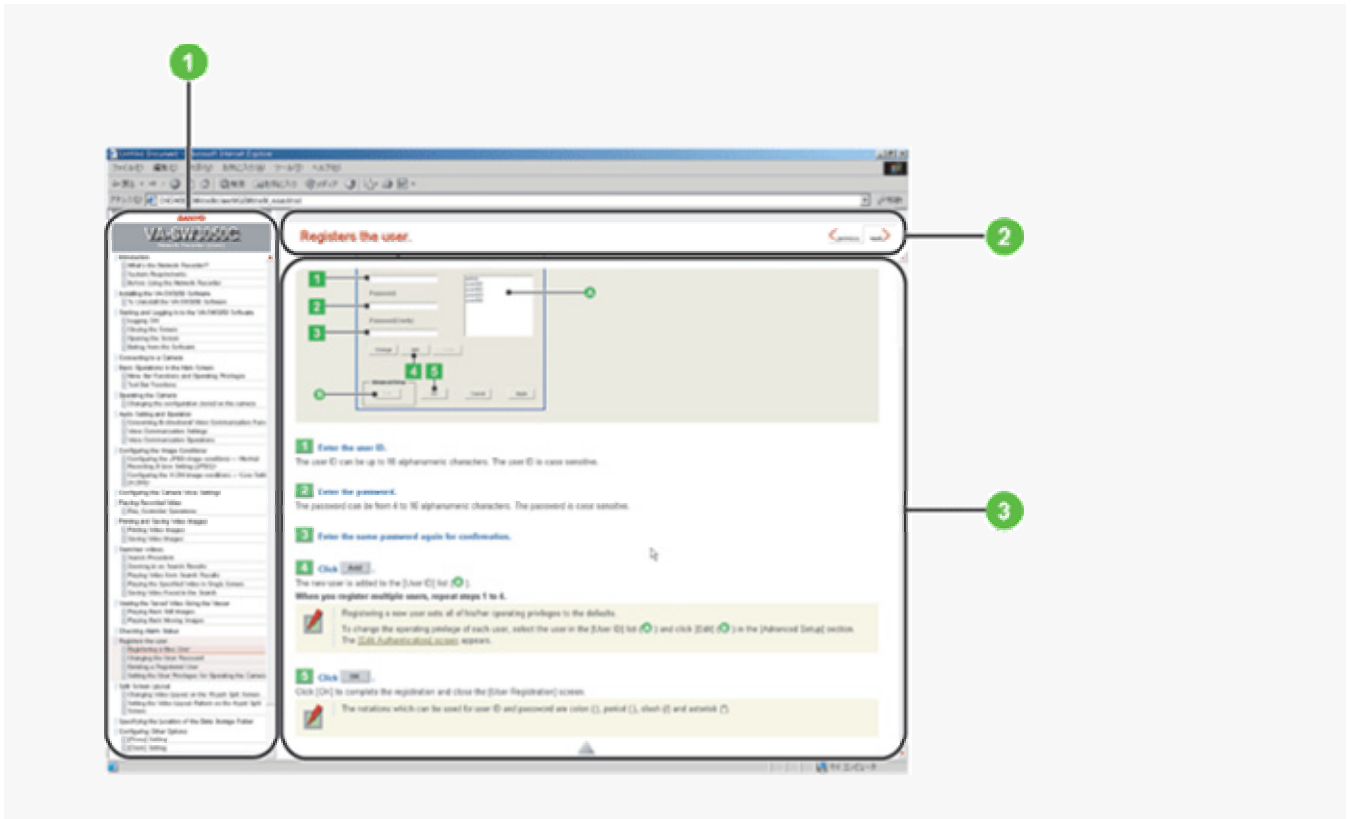

1 INDEX window

This window shows a table of contents.

The headline of the topic currently opened at the main window is highlighted, so the current location among the manual can be easily confirmed.

2 TITLE window

This window shows the headline of the current topic. This TITLE window never scrolls not to hide the headline.

3 MAIN window

This window shows the main detail contents.

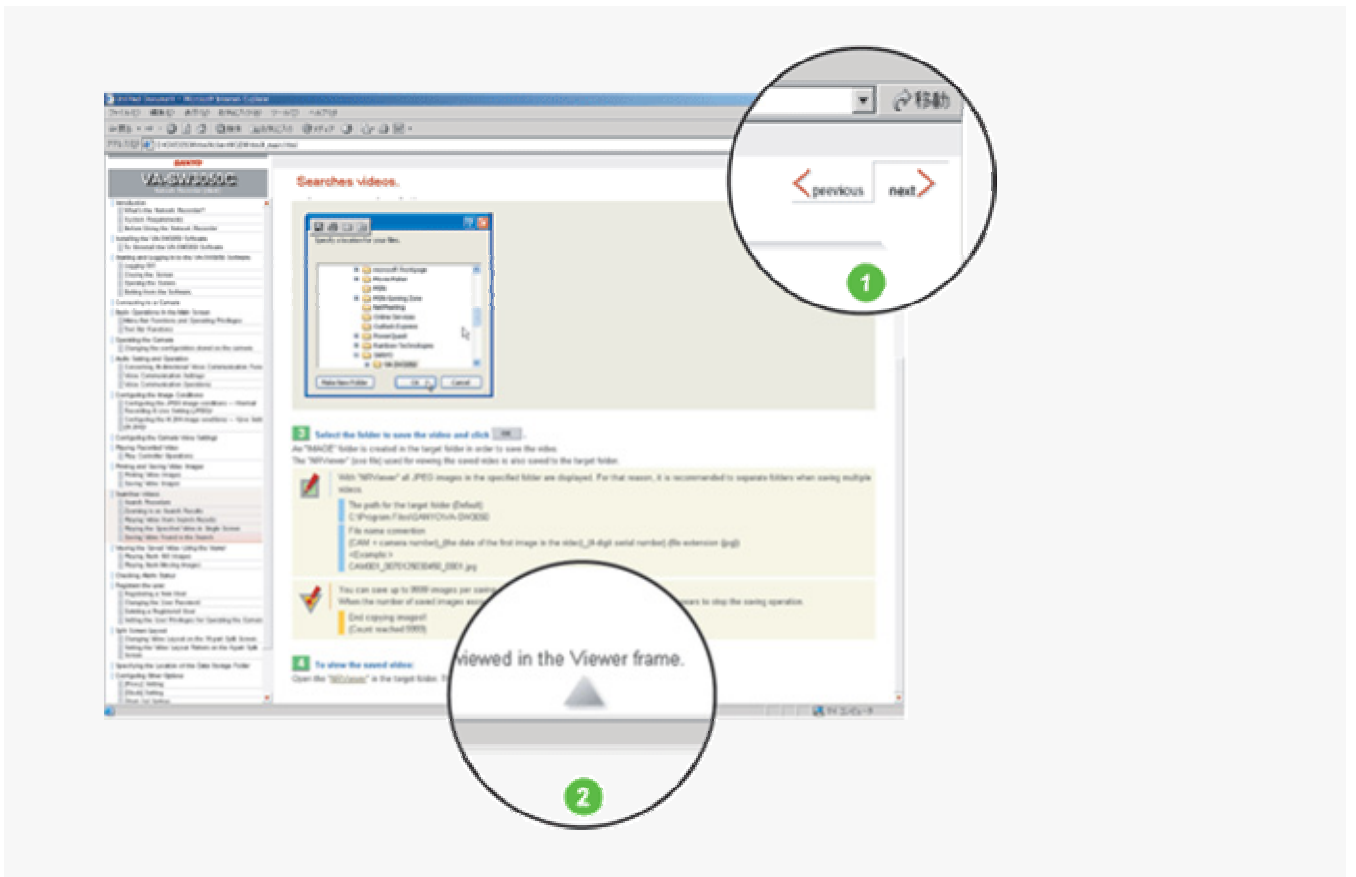

1 Previous/Next

Clicking  or  on the top right of the TITLE window will display the previous page or the next page, respectively.

2 Page end

 is located at the end of the page.

This mark is also linked to the top of the page. Click on this mark to jump to the top of the page.

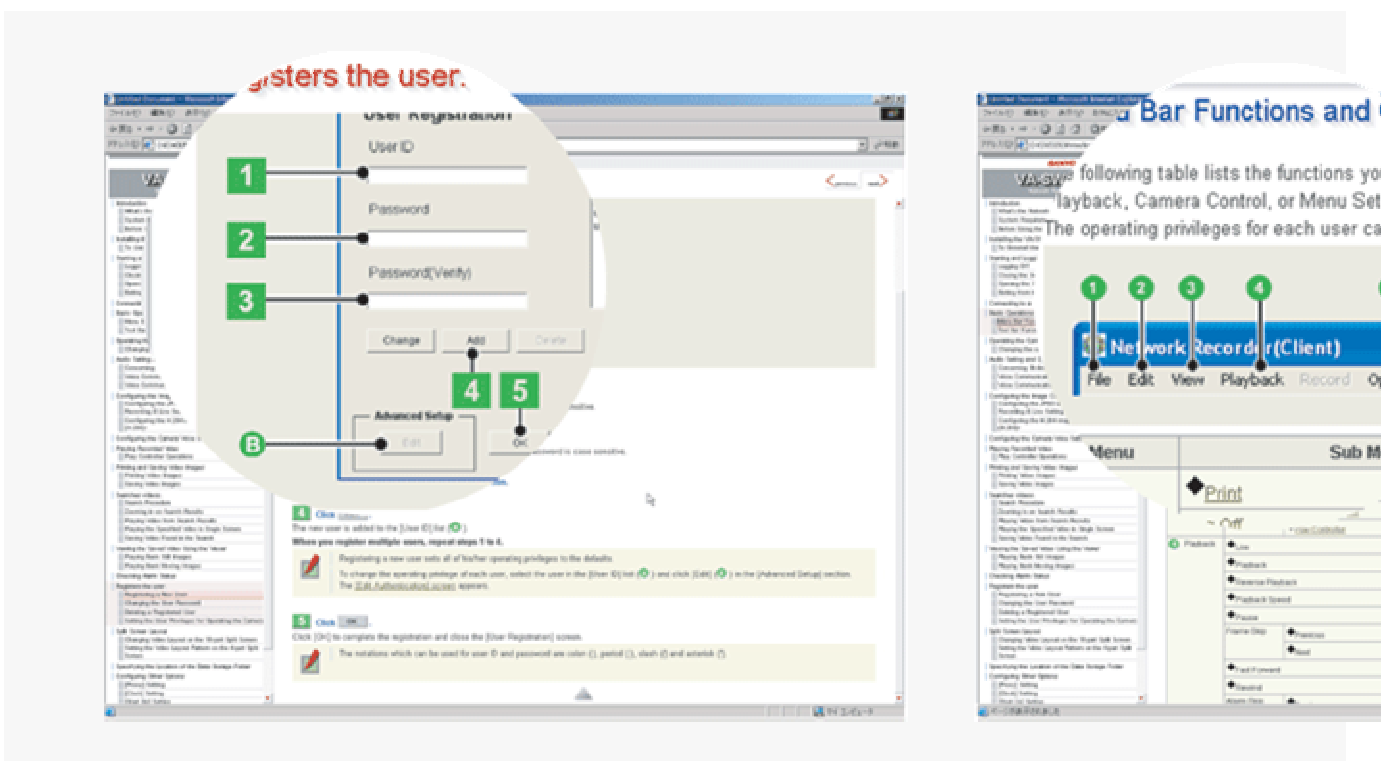

Numbers

123...

Boxed numbers indicate procedural instructions.

1 2 3 ... A B C ...

Circled numbers or circled alphabetic letters are used in sections that describe screen component names or other information.

Symbols

This manual uses the following three kinds of symbols depending on the content of the provided information.



Memo:
Indicates supplementary or related information.



Reference:
Provides references to the associated settings that must be configured on other menu screens.



Caution:
Indicates prohibited or restricted operating and setting instructions.

Uppercase Letters, Graphics, and Punctuation Marks

This manual uses the following notations to present user-interface related information:

Information such as the screen title is represented in all uppercase alphabetic letters, as displayed on the screen (Example: NETWORK SETTINGS).

Information such as operation buttons and icons are represented as graphics, as displayed on the screen (Example: SET).

The names of specific setting items, tabs, dialog boxes and the like are enclosed in square brackets [] (Example: [TITLE]).

The options or values that you select in a pull-down menu or using radio buttons are enclosed in double quotes " " (Example: "ON", "80").